



EX2100™ Excitation Control

Product Description

These instructions do not purport to cover all details or variations in equipment, nor to provide for every possible contingency to be met during installation, operation, and maintenance. The information is supplied for informational purposes only, and GE makes no warranty as to the accuracy of the information included herein.

Changes, modifications and/or improvements to equipment and specifications are made periodically and these changes may or may not be reflected herein. It is understood that GE may make changes, modifications, or improvements to the equipment referenced herein or to the document itself at any time. This document is intended for trained personnel familiar with the GE products referenced herein.

GE may have patents or pending patent applications covering subject matter in this document. The furnishing of this document does not provide any license whatsoever to any of these patents. All license inquiries should be directed to the address below. If further information is desired, or if particular problems arise that are not covered sufficiently for the purchaser's purpose, the matter should be referred to:

GE Industrial Systems

Post Sales Service

1501 Roanoke Blvd.

Salem, VA 24153-6492 USA

Phone: + 1 888 GE4 SERV (888 434 7378, United States)

+ 1 540 378 3280 (International)

Fax: + 1 540 387 8606 (All)

("+" indicates the international access code required when calling from outside the USA)

This document contains proprietary information of General Electric Company, USA and is furnished to its customer solely to assist that customer in the installation, testing, operation, and/or maintenance of the equipment described. This document shall not be reproduced in whole or in part nor shall its contents be disclosed to any third party without the written approval of GE Industrial Systems.

GE PROVIDES THE FOLLOWING DOCUMENT AND THE INFORMATION INCLUDED THEREIN AS IS AND WITHOUT WARRANTY OF ANY KIND, EXPRESS OR IMPLIED, INCLUDING BUT NOT LIMITED TO ANY IMPLIED STATUTORY WARRANTY OF MERCHANTABILITY OR FITNESS FOR PARTICULAR PURPOSE.

Original Issue Date: 2000-12-04

Rev. A Issue date: 2002-06-26

Rev. A includes addition of EMIO, EXHS, and EGPA Boards.

© 2002 by General Electric Company, USA.

All rights reserved.

Ethernet is a registered trademark of Xerox Corporation.

EX2100 is a trademark of General Electric Company, U.S.A.

Modbus is a trademark of Schneider Automation, Inc.

Section	Page
Introduction	2
Related Publications	2
Hardware	3
Digital Controller (Thyristor-Based Systems)	6
Power Control Module (Thyristor – SCR)	7
Redundancy (Power Bridge – Warm Back-Up)	8
Redundancy (Redundant Control – Simplex Bridge)	8
Cabinet	8
Digital Controller (IGBT-Based Systems)	8
Standards Supported	35
Control Boards	10
Customer Interface Boards	18
Internal Interface Boards	20
Modules	25
Software	27
Testing	33
Routine Factory Tests	33
Customer Witness Testing	33

Introduction

The EX2100™ Excitation Control System is GE's latest state-of-the-art control offering for both new and retrofit steam, gas, or hydro generation. GE has supplied more than 6,000 full static and regulator systems in over 70 countries during the last 40 years. EX2100 is GE's third generation digital excitation control system. There are over 1,000 first and second-generation GE digital excitation controls operating in 27 countries. Hardware and software design is closely coordinated between GE's system engineering and controls engineering to ensure delivery of a true system solution. Integration between EX2100, Mark VI, Mark VI Integrated Control System (ICS), LS2100 Static Starter, and human-machine interface (HMI) is seamless. For stand-alone retrofit applications, integration with customer distributed control systems (DCS) through serial or Ethernet® ModBus™ is supported.

Related Publications

GE provides system instruction documents for the different components of each product. For questions or additional documents, contact the nearest GE sales office or authorized GE sales representative.

Hardware

The EX2100 is available in several configurations to provide flexibility for full static and regulator control. These systems can support the following applications:

- Static Potential Source (voltage only) to 2000 amps (up to 8000 amps in 3Q, 2003)
- Static Compound Source (voltage and current) to 2000 amps
- Alterrex regulator
- SCT-PPT regulator
- Brushless and dc rotating exciter regulators

The architecture is one control module, the customer interface sub-system, local operator keypad, optional control operator interface (COI) remote interface device, control power input module, and the power module. The power module consists of a bridge interface sub-system, power bridge, ac and dc filter networks, and ac and/or dc isolation devices.

The EX2100 supports Ethernet local area network (LAN) communication to:

- Mark VI, Mark VI ICS, LS2100 Static Starter, and HMI using the Ethernet global data (EGD) protocol
- Customer DCS through ModBus
- GE Control System Toolbox (toolbox)
- The OnSite CenterSM for remote monitoring and diagnostics

EX2100 also supports RS-232C ModBus interface to a customer DCS. It incorporates a powerful diagnostic system and a control simulator to support fast installation, tuning of control constants, and training.

The following two diagrams show EX2100 max case major functional components, and board and interconnection overview.

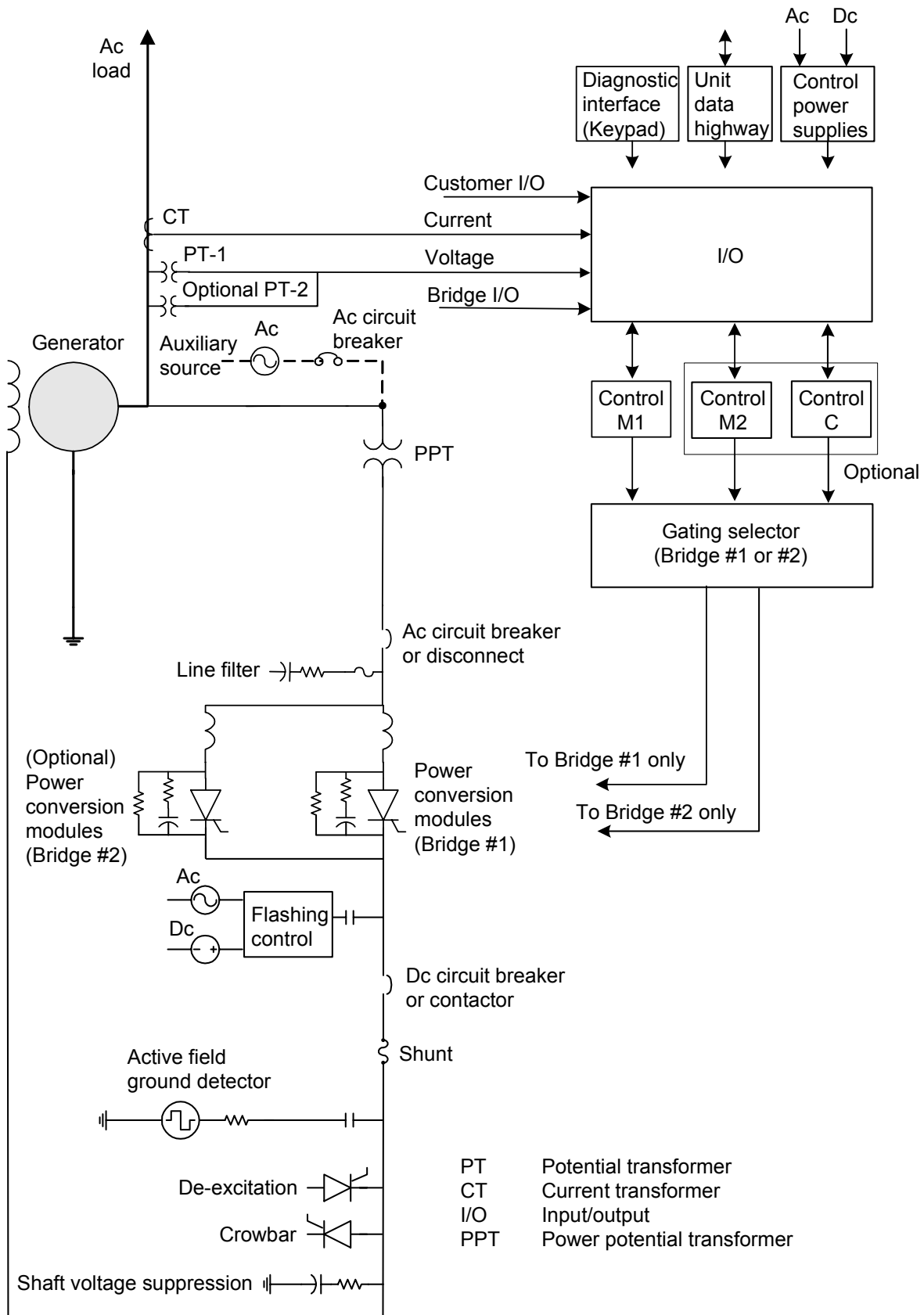

Simplified EX2100 Max Case Major Functional Components (Static System)

Ethernet data highway to turbine control and HMI

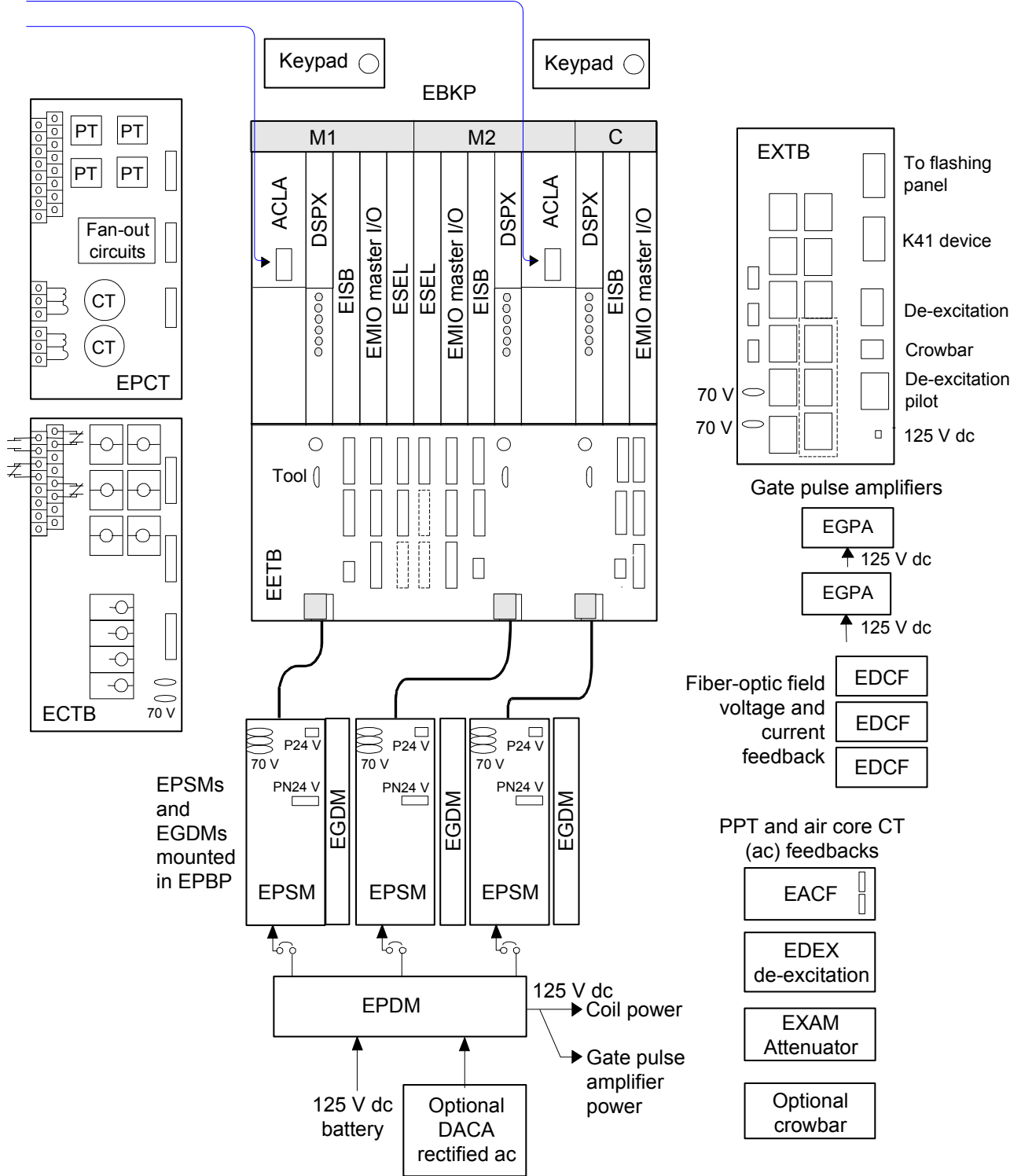

EX2100 Max Case Board and Interconnection Overview (Static System)

Digital Controller (Thyristor-Based Systems)

In redundant control configuration, the EX2100 features redundant exciter control with triple modular redundancy (TMR) for voted input/output (I/O) and protection, including the field ground detector function. As shown in the following diagram, the M1 and M2 control modules each contain two processor boards, the IS215ACLA Application Control Layer Module (ACLA) and IS200DSPX Digital Signal Processor Control Board (DSPX), for processing the application software. M1 and M2 are identical. The C controller is responsible for M1/M2 transfer and provides the third element of TMR I/O and protection. The C controller only has one processor board (DSPX). In simplex control configuration, only M1 is provided.

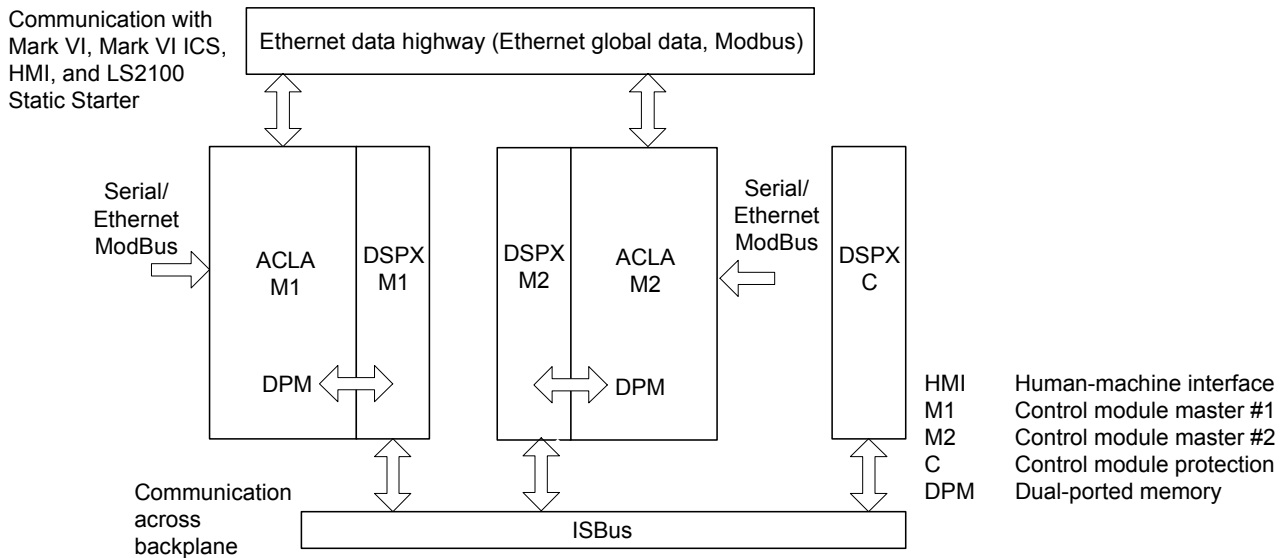

Processor Boards and Communications Paths in the EX2100 Control Assembly

The control module assembly contains up to six boards interconnected through the backplane and cabled to their associated I/O terminal boards: (see photo below)

- The main processor board (ACLA)
- The digital signal processor board (DSPX)
- Two I/O boards - IS200EMIO Exciter Main I/O Board (EMIO) and IS200ESEL Exciter Selector Board (ESEL)
- ISBus communication board, IS200EISB Exciter ISBus Board (EISB)



EX2100 Full Static Control Module

Power Control Module (Thyristor – SCR)

The 3-phase, full-wave, inverting thyristor (SCR) is the standard power conversion module for EX2100 Static exciters. The inverting bridge can provide both positive and negative forcing voltage for optimum performance. Negative forcing provides fast response for load rejection and de-excitation. Software changes of the firing circuits can be made to suppress negative forcing, if it is not required for the system application. Each rectifier bridge includes thyristor protection circuitry, such as snubbers, filters, and fuses.

The thyristor bridge assembly is forced-air cooled. For most applications, redundant cooling assemblies are used, all normally energized during operation. Thermostats monitor the power conversion module temperature. A set of alarm and trip contacts can trigger an alarm at a high temperature level, and a trip at an even higher temperature level.

A software-based conduction sensing circuit monitors each SCR bridge for blown fuses, missing gate pulses, or open/shorted SCRs.

Reactors are located in the ac legs feeding the SCRs. The snubbers are a resistor/capacitor (RC) circuit from the anode to the cathode of each SCR. The cell snubbers, line-to-line filters, and line reactors together perform the following functions to maintain proper operation of the SCRs.

- Limit the rate of change of current through the SCRs and provide a current dump to aid in starting conduction
- Limit the rate of change in voltage across each cell, and during cell commutation, limit the reverse voltage that occurs across the cell

Redundancy (Power Bridge – Warm Back-Up)

For small to medium sized static exciters, where the customer requires power bridge redundancy and the total power needs of the generator field can be supported within one power conversion module, the EX2100 Excitation Control system *warm backup* option is available. This option uses redundant controls (three controllers, M1, M2, and C) with two full-wave SCR bridges that share common ac input and dc output circuits.

The warm backup configuration is a cost-effective way to obtain N + 1 bridge redundancy when N = 1.

The active power bridge receives the gating commands from the active control (M1 or M2) and supports the full field voltage and current needs of the generator field while the backup power bridge's gating circuit is inhibited. The operator has full control to select which of the redundant power bridges is active or inactive. Bi-directional bumpless transfer between active and inactive bridges is standard. Sophisticated monitoring and protection circuits detect a failure or misoperation of the active power bridge, delay transfer (if needed to clear and SCR leg fuses), and activate the inactive power bridge without operator intervention.

Redundancy (Redundant Control – Simplex Bridge)

For instances where the customer requires a more economical redundancy, the EX2100 *redundant control, simplex bridge* option is available. This option utilizes redundant controls (three controllers, M1, M2, and C) with a single full wave SCR bridge. This system provides almost triple the mean time between forced outage (MTBFO) afforded by a simplex control with simplex bridge. Bi-directional bumpless transfer between active and backup controls is standard.

Cabinet

The exciter lineup is supplied in a NEMA 1/IP20 freestanding, indoor-type metal cabinet for floor mounting installation. The lineup consists of several cabinets bolted together, with cable entry through the top or bottom. The equipment is designed to operate in an ambient temperature range of 0° C to 40° C, but custom applications may support up to 50° C.

The standard cabinet color is ANSI-70 (light gray) on both exterior and interior surfaces.

Each cabinet consists of a rigid, self-supporting, enclosed panel with a full-length door to provide easy access to the equipment. The panel back serves as the rear of the cabinet. Each door is equipped with a suitable handle, three-point latch, and provisions for locking. The power bridge doors do not have handles, but are bolted closed to support code requirements.

Digital Controller (IGBT-Based Systems)

The EX2100 products offer a regulator control system with a 19 inch (480 mm) wide control/power backplane with supporting hardware based on the particular application. The control/power backplane may be either door or panel mounted.

The Regulator system may be purchased as part of a finished panel, or the individual components may be shipped loose for mounting at site to better serve retrofit applications.

The power conversion consists of an input section, a dc link, and the converter output section. The input section is a 3-phase diode bridge with input filters. The range of the ac input is from 90 – 280 V rms, nominal. Frequency inputs range as high as a nominal 400 Hz. Ac input may be single or 3-phase from a permanent magnet generator (PMG), auxiliary bus, or generator terminal. An input PPT is not required for the PMG input. A PPT is required for an auxiliary bus or generator terminal feed.

A backup source from nominal 125 or 250 V dc batteries is filtered, diode isolated, and combined with the 3-phase diode bridge output. These sources energize the dc link, an unregulated source voltage for the control core power supplies and the output power through the IGBTs. The dc link voltage level is limited by the dynamic discharge circuit during events such as load rejection or unit trip.

The converter output section uses IGBTs to pulse width modulate the dc link source voltage to its final value. The chopping frequency of the IGBTs is approximately 1000 Hz. This output is fed to the rotating exciter field as a regulated voltage or current. An output shunt monitors the field current. Continuous current output is provided up to 20 amps dc with 150% forcing (max 30 amps) for 10 seconds. There is a dc contactor within the control to apply current to the exciter field,

See section, Digital Controller (Thyristor Based Systems).

The control architecture (ACLA plus DSPX) of IGBT based systems versus Thyristor based systems is identical. Field ground detection and initial I/O processing is performed using different hardware.

A redundant version of the regulator will be available in 1Q, 2003. This system will perform as a warm backup, described earlier in this document. Note that both ac and dc input supply power, each capable of supporting full load regulator current, must be available to realize the full redundant capability of this system. The absence of either source input reduces MTBFO. However, even with one source removed, the MTBFO is better than twice that of the simplex regulator control.

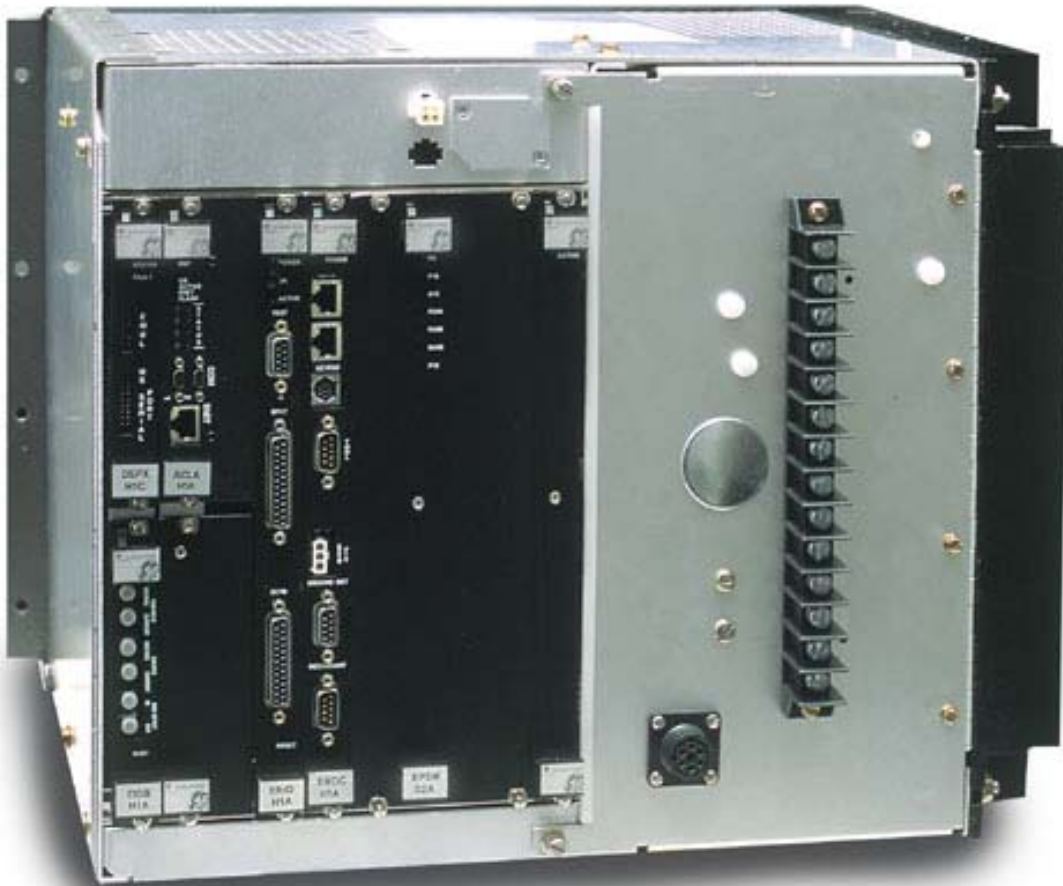

Exciter Regulator ERBP with Boards Mounted

Refer to descriptions found in this section.

The following boards are common to both full static and regulator control systems:

- Application Control Layer Module (ACLA)
- Digital Signal Processor Control Board (DSPX)
- Exciter Power Supply Module (EPSM)
- Exciter Contact Terminal Board(ECTB)
- Exciter PT/CT Board(EPCT)
- Exciter ISBus (EISB)
- Exciter Dc Feedback Board(EDCF)

Control Boards

Application Control Layer Module (ACLA)

The ACLA is a scaleable microprocessor-based controller, used for communication and control in the exciter. It mounts in the backplane and occupies two half-slots. The ACLA is based on a processor operating at 100 MHz, supporting 8 MB of dynamic random access memory (DRAM) and a 4 MB flash memory basic input/output system (BIOS). The ACLA is used as a communication gateway to external machines and as an outer loop controller/regulator.

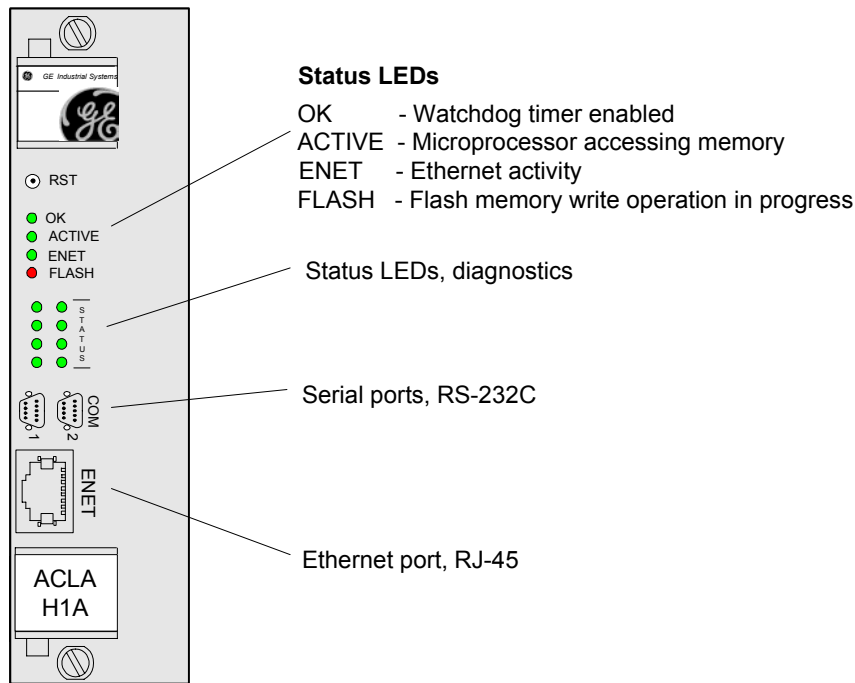

ACLA Faceplate Diagram

The ACLA communication gateway functions are:

- Ethernet
- Serial RS-232C
- Dual Port Memory (DPM)

The outer loop control/regulator functions are:

- Setpoint controller for the auto and manual regulators
- Generator voltage regulator (auto regulator)
- Var or power factor (PF) control
- Limiter functions
- Power system stabilizer
- Field temperature calculation
- Balance meter

Digital Signal Processor Control Board (DSPX)

The DSPX is the primary controller for inner loop control/regulators and local operator interface control supporting testing and setup. The board is based on a high speed, 60 MHz, digital signal processor chip supporting 248 kB of high speed static random access memory and a 512 kB flash memory BIOS.

Inner loop control/regulator function are:

- Field voltage regulator
- Field current limiter
- Sequencing of start-stop, field flashing, alarms and trips
- Generator instrumentation processing
- Generator simulator

Local operator interface control functions use a serial interface to a keypad and display unit mounted on the door of the control enclosure and supports:

- Display and changing of internal control data and alarm and status information from the DSPX or its paired ACLA controller
- Display and change of live data to support commissioning, tuning, and troubleshooting

Static Exciter Backplane (EBKP)

The IS200EBKP Exciter Backplane (EBKP) provides the connectivity between all the printed circuit boards mounted in it and cable connectors to external boards/modules that it supports. The backplane is physically mounted to the control module that is located in the control cabinet.

The EBKP is comprised of three major sections or divisions referred to as M1, M2 and C. These three sections are electrically isolated from each other with interconnections between sections either through differential transceivers or by transformer coupling.

Physically, the M1 section is located on the left side of the backplane and consists of ACLA, DSPX, EISB, EMIO, and ESEL boards and the connectors associated with them. The M2 section is next to the M1 section and contains the same type of boards. Section C is on the right side of the backplane and contains only DSPX, EISB, and EMIO boards and their associated connectors. Independent power supplies, each of which can be turned off separately, power the M1, M2, and C sections of EBKP.

Exciter ISBus Board (EISB)

The EISB is a special communication interface board for the M1, M2, and C control modules. ISBus is a proprietary, high-speed communication bus used in many GE systems. The EISB provides communication between the three DSPX boards in M1, M2, and C. EISB receives and transmits fiber-optic feedback signals through the backplane connectors. It also communicates between the DSPX and the tool and keypad ports using RS-232C. EISB is a single-slot, 3U high module that is located in the backplane below the DSPX. From six fiber-optic connectors on the front panel it accepts current and voltage signals from the generator field (and from the exciter if required) using IS200EDCF Exciter Dc Feedback Board(s) (EDCF), and receives and transmits signals to the IS200EGDM Exciter Ground Detector Module (EGDM).

Static Exciter Selector Board (ESEL)

The active ESEL, selected by controller C, sends the necessary control signals to the IS200EGPA Exciter Gate Pulse Amplifier Boards (EGPA).

The ESEL receives six logic level gate pulse signals from its corresponding EMIO. These pulse signals direct the gate command signals that are distributed to the exciter gate pulse amplifier (EGPA) boards through up to six sets of cables. The EGPA boards are mounted in the power conversion cabinet. If there are redundant controls, two ESEL boards are used, one driven by M1 and the other by M2.

Three groups of ESEL boards are available supporting increasing redundancy levels as follows:

- ESELH1 contains one bridge driver
- ESELH2 contains three bridge drivers
- ESELH3 contains six bridge drivers.

Static Exciter Main I/O Boards (EMIO)

The EMIO Board interfaces customer and system I/O to the DSPX processor. EMIO installs in the control rack.

Exciter Power Supply Module (EPSM)

The IS200EPSM Exciter Power Supply Module (EPSM) is used in the full static and regulator control systems. EPSM Group 1 modules (EPSMG1) are used in the full static system and EPSM Group 2 modules (EPSMG2) are used in the regulator control. EPSMG2 includes an IS200EPSD Exciter Regulator Power Supply Daughter board (EPSD) mounted to it.

The EPSM is comprised of 2 major sections, a buck-regulator and a push-pull inverter. The buck-regulator converts the input voltage to a 50 V dc intermediate voltage. This intermediate voltage is then applied to a push-pull inverter to create the required multiple output voltages. The transformer used in the push-pull inverter provides high-voltage isolation between the input voltage source and the output supplied to the control system.

In full static control systems, EPSMG1 converts 125 V dc from the IS200EPDM Exciter Power Distribution Module (EPDM) into the voltages required for the EX2100 excitation control. There are three independent EPSMG1s that supply power to each of the controllers M1, M2, and C. They are mounted in the IS200EPBP Exciter Power Backplane (EPBP) located below the EBKP in the control cabinet. Connectors P1 and P2 carry power from the EPSMG1 to EPBP that includes cable connectors to EBKP and other boards.

The EPSMG1 supplies +5 V dc, ± 15 V dc, and +24 V dc to EBKP. Power is also supplied to external modules as follows:

- ± 24 V dc to power the fans, de-excitation module, crowbar module, the ground detector module, and the field voltage/current module
- Isolated +70 V dc for contact wetting to the terminal boards

In regulator control, EPSMG2 converts the dc link bus voltage into the voltages required for the EX2100 regulator control. In simplex systems, one EPSMG2 is mounted in the IS200ERBP Exciter Regulator Backplane (ERBP). In redundant systems, one EPSMG2 is mounted in ERBP (M1) and a second EPSMG2 is mounted in the IS200ERRB Exciter Regulator Redundant Backplane (ERRB, M2/C).

The EPSD that is mounted on EPSMG2 modifies the power input path to allow EPSMG2 to accept higher voltages by increasing the creep and clearance. It also provides a fuse between the regulator power source (dc link) and the buck-regulator.

The EPSMG2 supplies +5 V dc, ± 15 V dc, and +24 V dc to the ERBP and ERRB. Power is also supplied to external modules as follows:

- ± 24 V dc (P24B/N24B) to power fans, relays, and the dc feedback board
- Isolated +70 V dc (P70) for contact-wetting on the terminal board, dynamic discharge board, and redundant relay board
- Isolated 20 V ac (AC17) to power the insulated gate bipolar transistor (IGBT) gate and dynamic discharge board
- ± 55 V dc (P55/N55) to the ground detector circuits on the options card

Static Exciter Power Backplane (EPBP)

The EPBP holds three independent EPSMG1 power supply modules that supply logic level power to the M1, M2, and C controllers. It also holds three EGDM ground detection modules. EPBP is supplied with 125 V dc power from the EPDM through three cable connectors. Backplane connectors P1 and P2 carry power from the EPSM to EPBP.

EPBP distributes +5 V dc, ± 15 V dc, and +24 V dc power (from EPSM) to the control backplane (EBKP) through cable connectors. Power is also supplied to external modules as follows:

- ± 24 V dc to power the de-excitation module, crowbar module, ground detector, and the field voltage/current module (EDCF).
- Isolated +70 V dc for contact wetting to the EXTB and ECTB boards.

Field Ground Detector (EGDM)

The EGDM detects leakage resistance to ground from any point in the field circuit starting at the ac secondary windings of the input transformer, through the excitation system, and on the generator field. The active detection system applies a low voltage with respect to ground and monitors current flow through a high impedance ground resistor. Grounds anywhere in the system can be detected even while the exciter is not running (gating SCRs).

This field ground detector (patent pending) also features:

- Constant sensitivity to grounds independent of operating voltages on the generator field
- Constant sensitivity to grounds without regard to ground location in the generator field
- Location detection of field ground

The ground detector voltage is sent over a fiber-optic link to the EISB board for monitoring.

Exciter Regulator Backplane (ERBP)

The ERBP provides the connectivity between all the printed circuit boards mounted in it and cable connectors to externally mounted boards/modules that it supports. The ERBP is used in simplex and redundant regulator control applications.

In simplex applications the ERBP contains an ACLA, DSPX, IS200ERIO Exciter Regulator I/O Board (ERIO), EPSM, IS200ERDD IGBT Exciter Regulator Interface and Dynamic Discharge Board (ERDD), IS200EROC Exciter Regulator Options Card (EROC), and the connectors associated with those boards. In redundant applications it contains the same boards and is designated as the M1 control. Optionally, the ERBP can also contain an EISB board. Refer to the following diagram for ERBP layout.

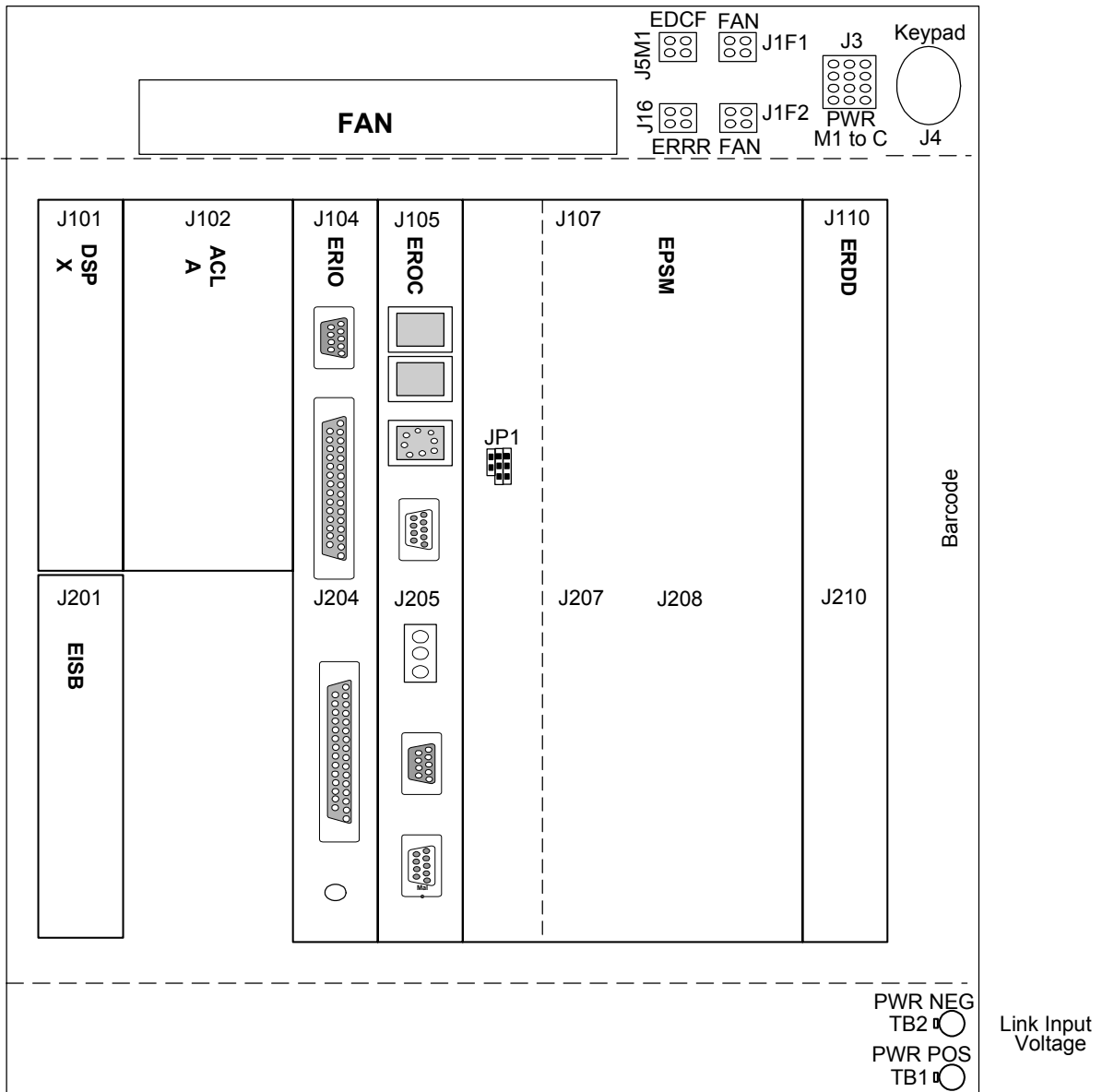

ERBP Block Diagram

Exciter Regulator Redundant Backplane (ERRB)

The ERRB provides the connectivity between all the printed circuit boards mounted in it and cable connectors to externally mounted boards/modules that it supports. The ERRB is comprised of the M2 and C control sections of the regulator for redundant applications. The M2 control section consists of an ACLA, DSPX, ERIO, EPSM, ERDD, EROC, and the connectors associated with those boards. The C control section consists of a DSPX, ERIO, EISB, and the connectors associated with those boards. Optionally, the M2 control section can also contain an EISB board.

A redundant regulator consists of an M1 backplane (ERBP), an M2/C backplane (ERRB), and terminal boards ECTB and EPCT. Refer to the following two diagrams for ERRB layout and redundant application power distribution.

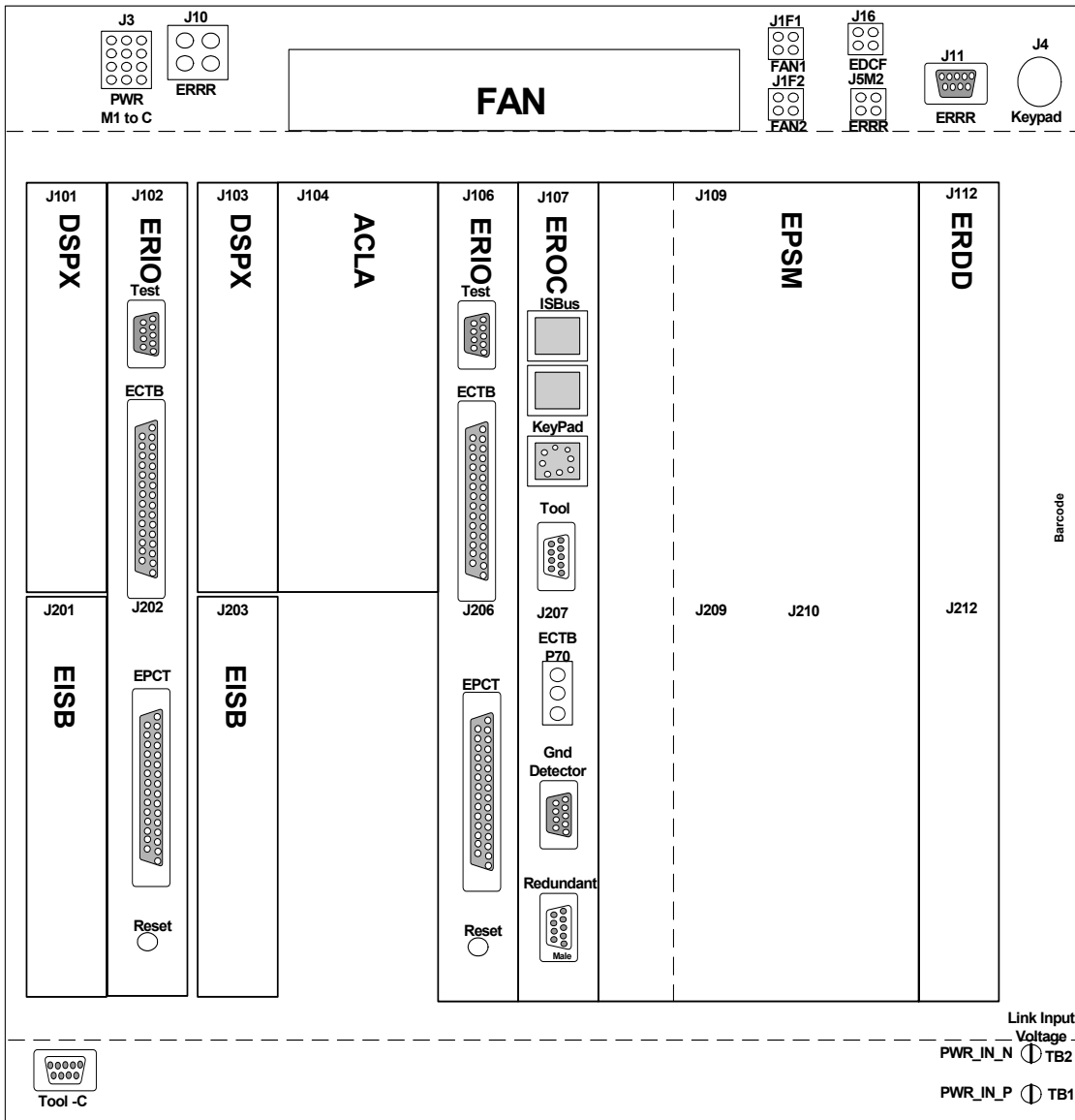

ERRB Block Diagram

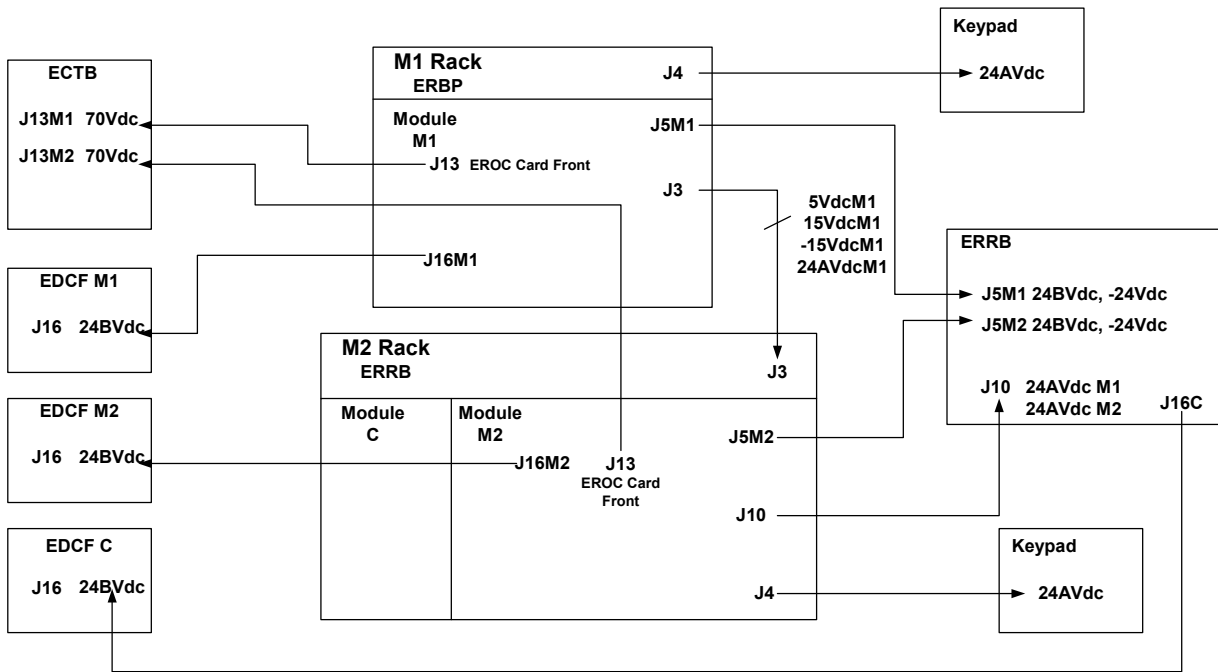

Redundant System Power Block Diagram

Exciter Regulator I/O (ERIO)

The ERIO board provides the I/O interface for customer and system I/O in the EX2100 Regulator Control systems (simplex and redundant). For **simplex** applications, it is mounted in ERBP and interfaces customer I/O signals for the EPCT and ECTBG2 terminal boards. It also interfaces system I/O signals for the ERDD and the EROC for simplex applications.

For **redundant** applications, it is mounted in the ERBP (M1) and also in the ERRB (M2/C) and interfaces customer I/O signals for the EPCT and ECTBG1 terminal boards. It also interfaces system I/O signals for the ERDD, EROC, and the IS200ERRR Exciter Regulator Redundant Relay board (ERRR) for redundant applications.

The ERIO, EPCT and ECTB boards are interconnected through two 25-pin connectors to ERBP (M1 in redundant) and also to ERRB (M2/C) in redundant applications. One ERIO each is provided in the M1, M2, and C control sections.

An onboard field programmable gate array (FPGA) is used to control data acquisition and storage into dual port memory (DPM). The DPM is accessible by the DSPX board from the backplane.

The ERIO, EROC and ERDD boards are connected through the ERBP (simplex) and ERRB (redundant) backplanes, The ERIO and ERRR are interconnected through one 25-pin connector in the backplane (ERBP, ERRB).

Exciter Regulator Options Card (EROC)

The EROC provides support for the regulator options:

- GE ground detector
- Third-party ground detectors
- Keypad support
- Terminal board power connection

The EROC supports a single third-party ground detector with up to three inputs:

- Ground Alarm input
- Ground Detector Malfunction
- Diode Fault Monitor.

The EROC communicates with the keypad using RS-232C and provides data transmission to two locations in the regulator rack. A keypad connector is located on the EROC faceplate and another on the backplane (ERBP simplex, ERRB redundant). Only one keypad can be connected to a module. The two locations are to support mounting variation of the backplane.

Customer Interface Boards

Exciter PT/CT Board (EPCT)

The IS200EPCT Exciter PT/CT Board (EPCT) contains isolation transformers for critical generator voltage and current measurements. The following signals are input to EPCT and interfaced to the EMIO board:

- Two 3-phase generator potential transformer (PT) voltage inputs
- Two generator current transformer (CT) current inputs (1 A or 5 A)
- One analog input (can be either 0–10 V or 4–20 mA)

Exciter Contact Terminal Board (ECTB)

The IS200ECTB Exciter Contact Terminal Board (ECTB) supports excitation contact outputs and contact inputs. There are two versions that are used as follows:

- ECTBG1 (redundant applications only)
- ECTBG2 (simplex applications only)

Each board contains two trip contact outputs driving a customer lockout and four general purpose Form-C relay contact outputs controlled by the EMIO board. Six auxiliary contact inputs are powered (wetted) with 70 V dc by ECTB. Also, the 52G and 86G contact inputs are powered and monitored by ECTB. In redundant applications, power comes from the M1 and M2 power supplies.

Static Exciter Power Distribution Module (EPDM)

The EPDM provides power for the control, I/O, and protection boards of the exciter. It is mounted on the side of the EPBP and receives 125 V dc power from the station battery and accepts one or two 120 V ac power inputs for backup. All power inputs are through a board mounted terminal block and are filtered. Each ac supply is rectified to 125 V dc in an external ac-to-dc converter and the resulting two or three dc voltages are diode coupled through external diodes to create the dc source power supply.

Ac power for the bridge cooling system comes from breakers included in the exciter.

Individual power supply outputs to each of the exciter boards are fused, have an on/off toggle switch (except EXTB) and a green LED indicator to show power availability. The outputs supply up to three EGPA boards, EXTB, and three EPSMs serving three controllers. A separate connector is provided for each output and these are wired to the EPBP for distribution.

Control Operator Interface (COI, Remote/Local)

Remote or local (exciter door) control is supported.

The COI is an embedded pc based interface using a liquid crystal diode (LCD) display that supports graphical and character displays. Multiple screen displays for operation and diagnostics are supported. Configuration is supported using the same GE Control System Toolbox (toolbox) software that interfaces with the exciter control hardware and software.

Local Operator Interface (Keypad)

The keypad is a local operator interface mounted on the cabinet door. Start/stop commands, regulator transfer commands, and regulator selection can be issued from the keypad. The keypad also includes meter displays indicating system conditions, such as generator MW and MVars, field current and voltage, and regulator balance. Diagnostic displays such as the alarm history, setup, application data, and I/O interface displays provide system information for service personnel.

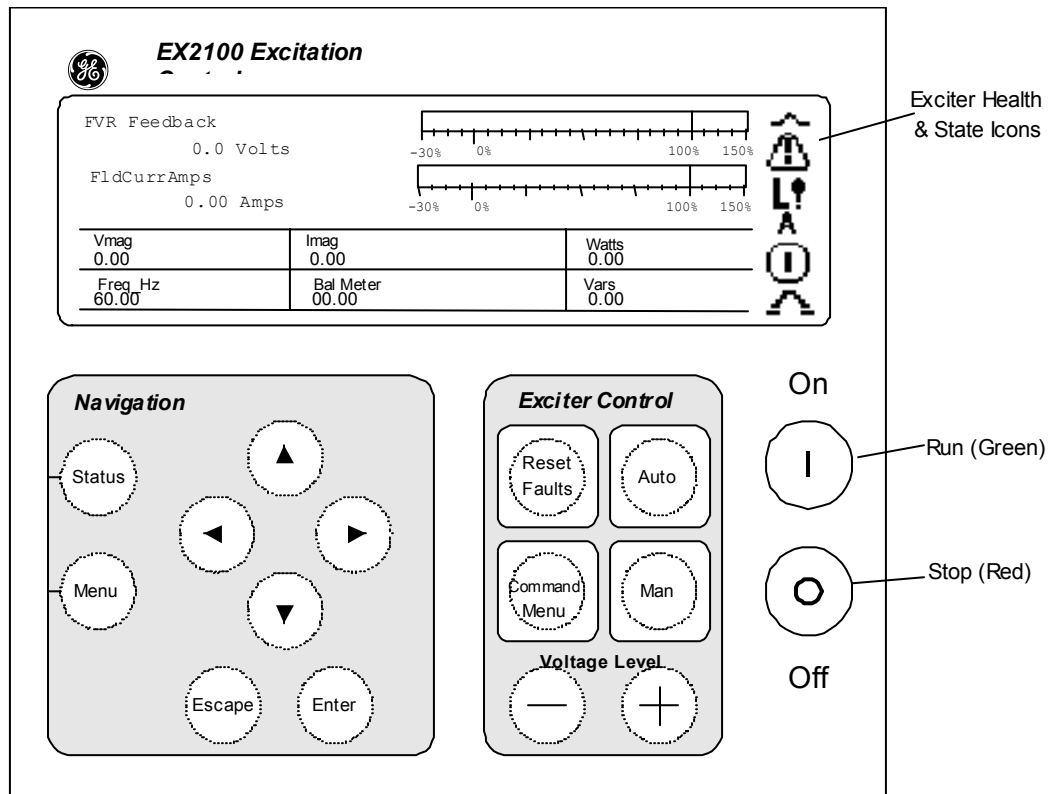

Display:

Status screens provide analog and digital representation of exciter functions and values.

Menu screens provide text-based access to parameters, wizards, and faults.

Pushbuttons:

Organized into functional groups:

Navigation buttons for using the menu

Exciter Control buttons

Run and **Stop** buttons

Local Operator Keypad

Exciter Regulator Third-party Ground Detector Terminal Board (ERGT)

The IS200ERGT Exciter Regulator Third-party Ground Detector Terminal Board (ERGT) is the interface between the EROC and third-party field ground detectors. It converts the 9-pin connector from the EROC to terminal landing screws to interface to the third-party ground detector. The ERGT can be DIN-rail or wall mounted.

Internal Interface Boards

Static Exciter Terminal Board (EXTB)

The IS200EXTB Exciter Terminal Board (EXTB) supports pilot relay contact outputs, contact inputs, and signal conditioning circuits. EXTB is connected to EBKP, which distributes the signals to the EMIO board through its P1 and P2 backplane connectors.

Pilot relays for the following are provided by EXTB:

- Close 41 breaker/contactors
- Trip relay 41T
- Flashing contactors 53A and 53B
- De-excitation relay KDEP

Crowbar status signals and de-excitation status signals from the IS200EDEX Exciter De-excitation Control Board (EDEX) are conditioned on EXTB and sent to EMIO. Three contact inputs from 41, 53A, and 53B are powered (wetted) by 70 V dc on EXTB. Power for the contacts is from the M1 and M2 power supplies (redundantly) and the resulting status signals are sent to EMIO.

Static Exciter High Speed Terminal Board (EXHS)

EXHS is identical to EXTB except it has a solid state relay driver for the 41 Dc contactors. This board is used with a high speed contactor to provide protection in higher current applications.

Static Exciter Gate Pulse Amplifier Board (EGPA)

The EGPA board interfaces the control to the power bridge. EGPA takes the gate commands from the ESEL and controls the gate firing of up to six silicon controlled rectifiers (SCRs) in the power bridge. It also is the interface for current conduction feedback, and the bridge airflow and temperature monitoring.

The EGPA functional model with the major I/O is shown in the following figure. A nominal 130 V dc power source supplies an onboard dc/dc converter, which provides the isolated power for SCR gating over the full range of input supply voltage. LEDs provide visual indication of the status of the output firing, currents into the bridge, power supply, line filter, cooling fan rotation, bridge temperature, and alarm or fault conditions.

Static Exciter High Voltage Gate Pulse Amplified Board (EHPA)

The EHPA board is similar to EGPA. It is used in systems with PPT voltages above 1000 V ac.

Different groups of EXTB are available for controlling either a field breaker or a contactor in the field circuit.

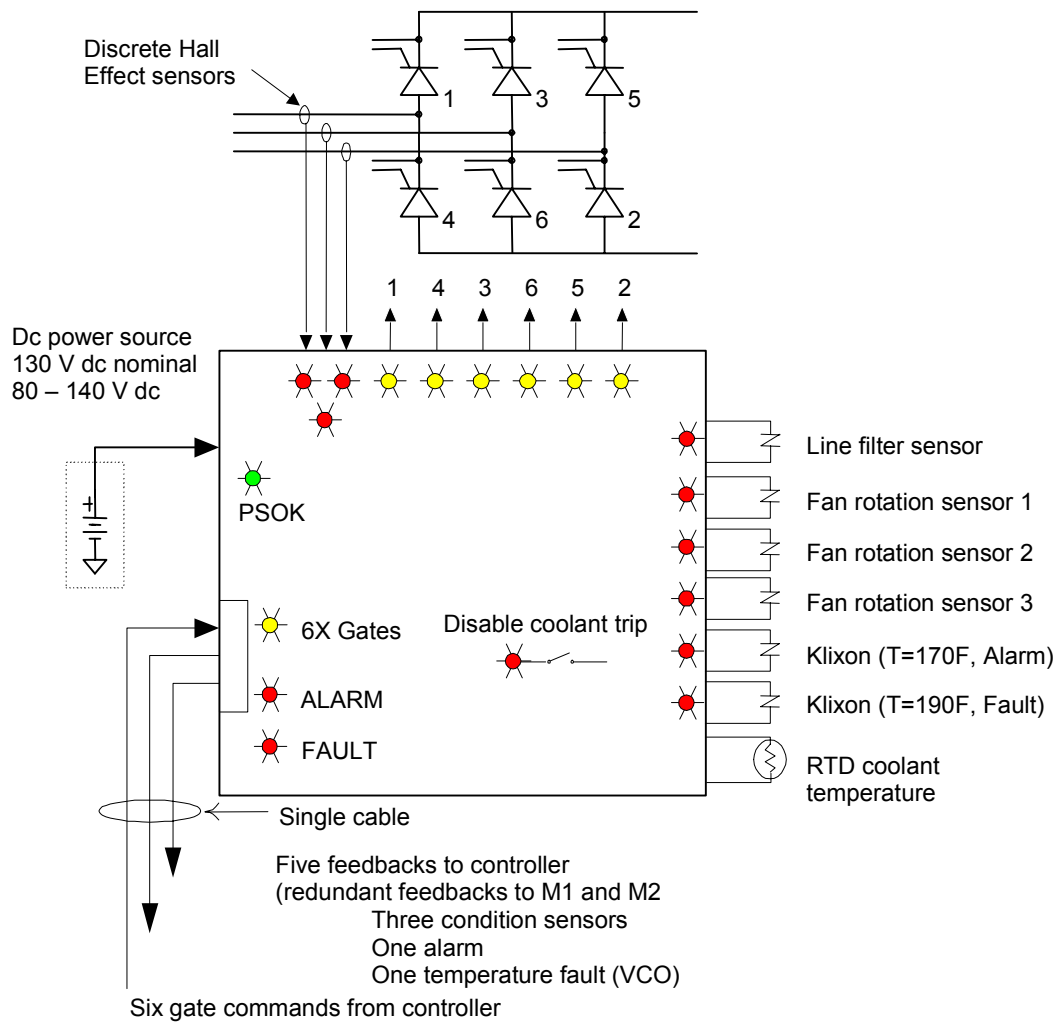

EHPA/EGPA Interface Diagram

Exciter Dc Feedback Board (EDCF)

The EDCF board measures field current and field voltage at the SCR bridge and interfaces to the EISB board over a high-speed fiber-optic link. The fiber-optic link provides voltage isolation between the two boards, and high noise immunity. Field current is measured using a shunt in the dc field circuit. The field voltage feedback circuit provides seven selector settings to scale down the bridge voltage, depending on the type of bridge application.

Exciter Ac Feedback Board (EACF)

The IS200EACF Exciter Ac Feedback Board (EACF) measures the exciter power potential transformer (PPT) ac supply voltage and current. The EACF terminal board contains transformers for a 3-phase voltage measurement, and terminals for two flux/air core coils. The outputs of the voltage and current circuits are fanned out to three DB9 connectors for cables to controllers M1, M2, and C. These cables can be up to 90 m in length. There are three versions of this board: EACFG1 is for inputs up to 480 V rms, EACFG2 is for inputs up to 1000 V rms, and EACFG3 is for inputs over 1000 V rms.

Exciter De-Excitation Module (EDEX)

The EDEX board is the main board in the de-excitation module. EDEX provides de-excitation SCR firing, conduction sense feedback, and voltage retention to ensure operation in the event of a power failure. EMIO initiates de-excitation on the EXTB board. The EXTB board opens the 41 dc contactor (41A/41B) or breaker, and then transfers de-excitation signals from the auxiliary contacts to SCR firing circuits on the EDEX.

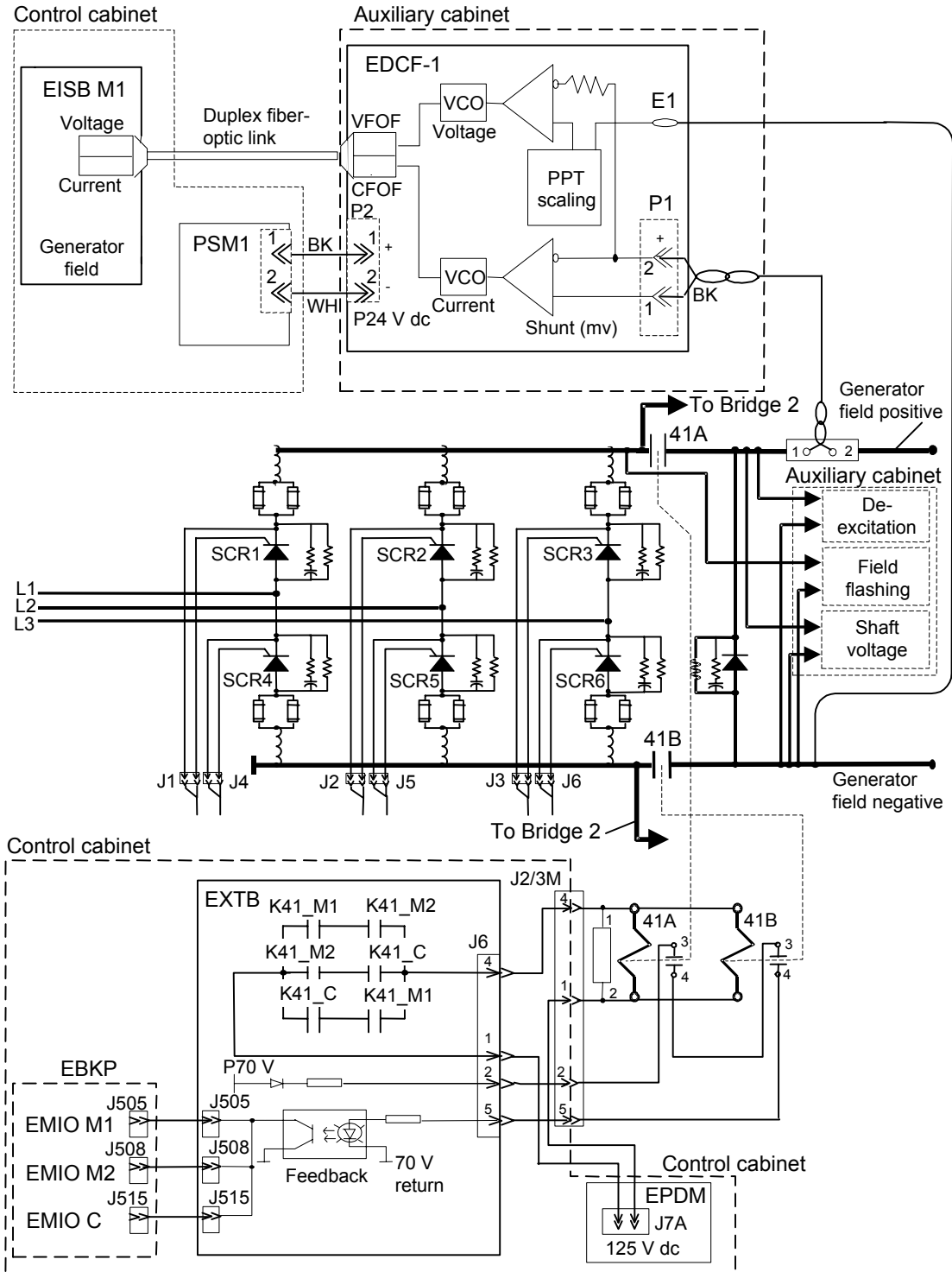

Power Control Module and Interface Diagram

Exciter Attenuator Module (EXAM)

The IS200EXAM Exciter Attenuator Module (EXAM) provides attenuation between the exciter field bus and the field ground detector (EGDM, described previously). The EXAM senses the high voltage from the bridge and scales this to a usable voltage level for the EGDM.

There is only one EXAM board present in most simplex and redundant applications.

The EGDM and EXAM are interconnected through a single cable with 9-pin connectors. The backplane completes the connection of the 9-pin connector to the 96-pin P2 connector of the EGDM board(s).

IGBT Exciter Regulator Interface and Dynamic Discharge (ERDD)

The ERDD is used in the EX2100 Regulator Control, simplex and redundant applications. For **simplex** applications, one ERDD is mounted in the ERBP and interfaces with the ERIO and the IS200ERSC Exciter Regulator Static Converter board (ERSC). In **redundant** applications, one ERDD is mounted in ERBP (M1) and a second ERDD is mounted in ERRB (M2/C) and interfaces with the ERIO, ERSC, and the IS200ERRR Exciter Regulator Redundant Relay board (ERRR).

The ERDD provides the following major functions:

- Gate drive control for field excitation
- Dynamic discharge to control excessive dc link voltage
- Bridge feedback to monitor dc link voltage, output shunt current, output field voltage, bridge temperature, and IGBT gate drive status (power supplies and de-saturation conditions)
- Control of the de-excitation relay (K41) in simplex applications or control of the charging relay (K3) in redundant applications

The following diagram shows the ERDD applied to the simplex regulator system:

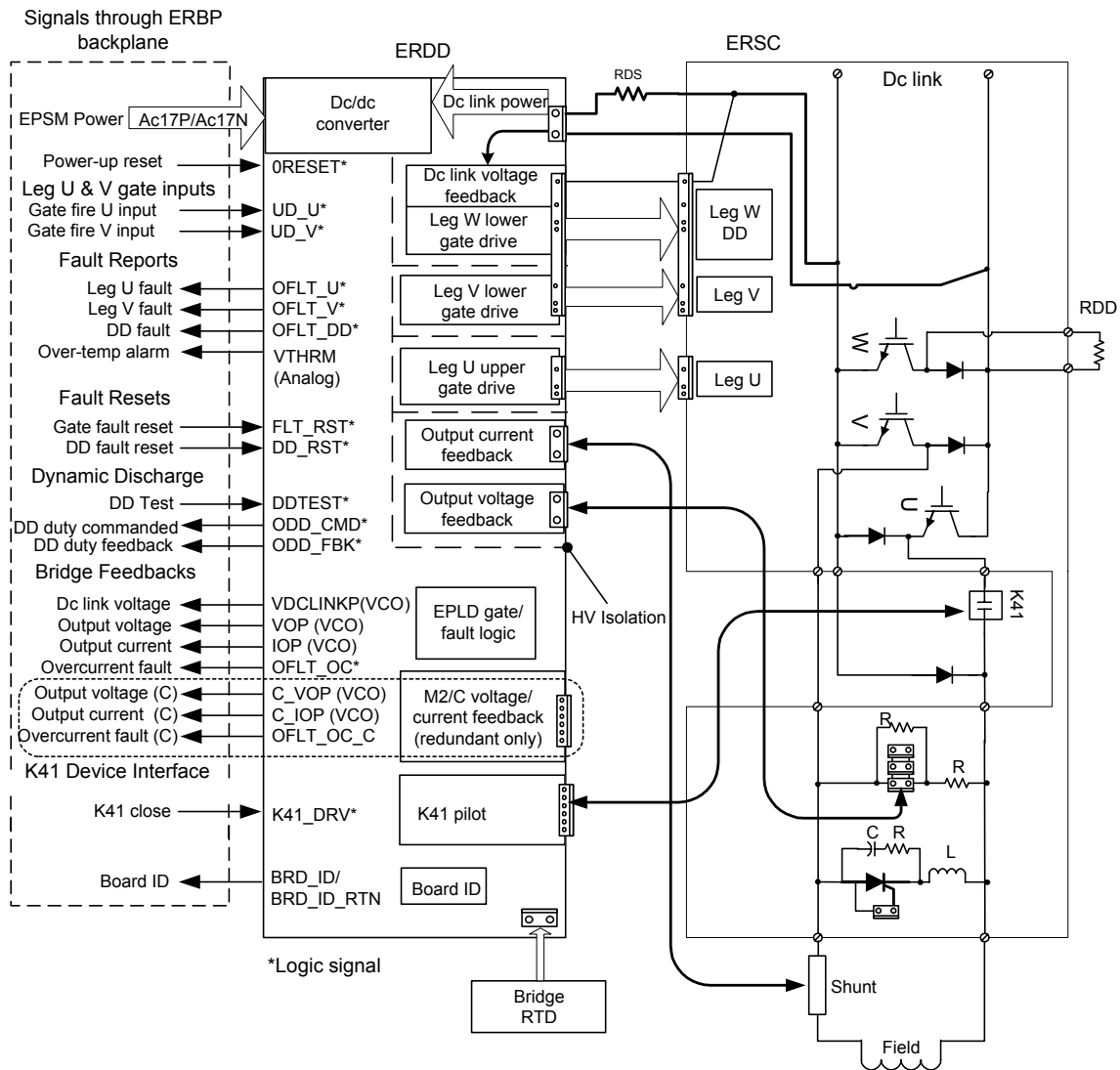

ERDD Application in EX2100 Regulator Control (Simplex)

Exciter Regulator Redundant Relay (ERRR)

The ERRR board is used in the redundant regulator control applications only. The ERRR drives/monitors the K41 pilot relay, K5T module transfer relay, and module transfer SCR. The K41 pilot relay drives the K41 bridge output contactor. The K5T module transfer relay, when energized, turns on the transfer SCR which in turn redirects field current during the transition from M1 to M2 or M2 to M1 controls and bridge.

The ERRR also passes bridge voltage feedback, bridge current feedback, and bridge overcurrent faults to the regulator controls.

Exciter Regulator Static Converter (ERSC)

The ERSC board provides the pulse width modulated (PWM) dc output current and the field discharge function for the regulator control. These two functions are defined as the power conversion module (PCM).

The PCM consists of an integrated IGBT inverter module that contains six IGBTs connected in a 3-phase inverter configuration. Two of the six IGBTs are used to create the PWM dc output for field excitation. A third IGBT is used to discharge the dc link capacitors into an external dynamic discharge (DD) resistor. Maximum output is 20 A dc continuous, 30 A dc for 10 seconds. Input power is either rectified ac, dc from a station battery, or both.

A relay, K3, is provided to bypass the dc link charging resistor. The dc link charging resistor provides a soft charge on initial power up for the dc link capacitors.

Modules

Dc Interrupting Device

For most applications a field interrupting dc contactor in the rectifier bridge dc positive output is used to connect the exciter to the generator field leads. The dc contactor and the de-excitation module together form the internal *field breaker* function used to remove stored energy in the generator field during trip events. Often, two dc contactors are provided to interrupt both the positive and negative field leads.

For some applications, an external exciter field breaker is offered. Dc field breakers interrupt the output of the exciter and use a shorting contact to de-excite the generator field through a discharge resistor. For many applications, the dc field breakers may use a de-excitation module in place of the shorting contractor as a more cost effective option.

Ac Isolation Device

An internal manual ac disconnect switch is offered for small to medium size systems, below 600 V ac. This switch is a disconnect device between the secondary of the PPT and the power bridge in the static exciter. In most cases, it is a molded case, 3-phase, manually operated, panel-mounted switch. This switch permits the customer to close and open the ac input supply.

An external ac disconnect breaker can be offered for larger systems. This breaker is a disconnect device between the secondary of the PPT and the static exciter. It may be a molded-case or a vacuum breaker supporting remote control. This breaker permits the customer to close and open the ac input supply.

Shaft Voltage Suppressor

The shaft voltage suppressor is a filter that conducts the high frequency components of voltages to ground.

The shaft voltage suppressor limits shaft voltage to ground (caused by thyristor commutation) to less than 5–7 V, zero to peak. Shaft voltage, if not effectively controlled, can damage both journals and bearings. Full static control systems cause ripple and transient voltages at the exciter output. Due to their rapid rise and decay times, these voltages are capacitively coupled from the field winding to the rotor body. This creates a voltage on the shaft relative to ground.

The shaft voltage suppressor is shipped loose (for mounting at the collector of the generator) in most large applications. For smaller applications, the shaft voltage suppressor is part of the main exciter lineup.

Crowbar Module

A crowbar circuit is applied for most hydro applications (salient pole generators) and some steam or gas applications (wound rotor generators). During a pole slip event (when the generator loses synchronism with the power grid), high voltages can be induced from the generator stator back on the generator field. This high voltage can damage the excitation system and/or the generator field if the induced voltage rises above destructive levels. The crowbar safely limits the induced voltage below the destructive level for the excitation system and the generator field.

The hardware used to implement the crowbar function is the de-excitation module with the thyristor direction changed. The load for the crowbar must be a resistor, but the resistor can be shared with the de-excitation function. The functionality of the crowbar, thyristor with snubber, and conduction sensor, are the same as for the de-excitation module. The crowbar's thyristor is turned on when the anode to cathode voltage of the SCR exceeds a certain value. Once the crowbar conducts, the reverse current induced by the pole slip event has a conduction path thus limiting the voltage on the generator field and exciter output.

Field Flashing Module

The field flashing module supplies approximately 15 to 20% of no-load field current to the generator field during the startup sequence. Field flashing from a dc power source is the standard method of flashing, however an ac field flashing module is also available.

The dc field flashing module is powered from either a 125 V dc or 250 V dc station battery and has a maximum rating of 350 A dc for 15 seconds.

The ac field flashing control is almost identical to the dc field flashing control, however the ac voltage is rectified by a diode bridge and filtered. The diode bridge also serves as a freewheeling diode circuit. This module accepts a 460 V ac single-phase input that is then stepped down to 27 V ac through a transformer. The module is rated for a maximum of 350 A dc for 15 seconds.

Battery Filter, Ac Line Filter Modules

The battery and ac line filters are provided for transient and noise suppression to ensure proper operation of the EX2100 Regulator Control. A battery filter is provided whenever dc input power is supplied from station battery. The ac line filter is provided when the ac input source is an auxiliary bus or the generator terminals.

The ac line filter is not required in PMG applications.

Software

The EX2100 software is designed to support high performance and structured to help the customer and field engineers to understand, install, commission, tune, and maintain the excitation control system. The following sections define major software functions shown in the diagram below:

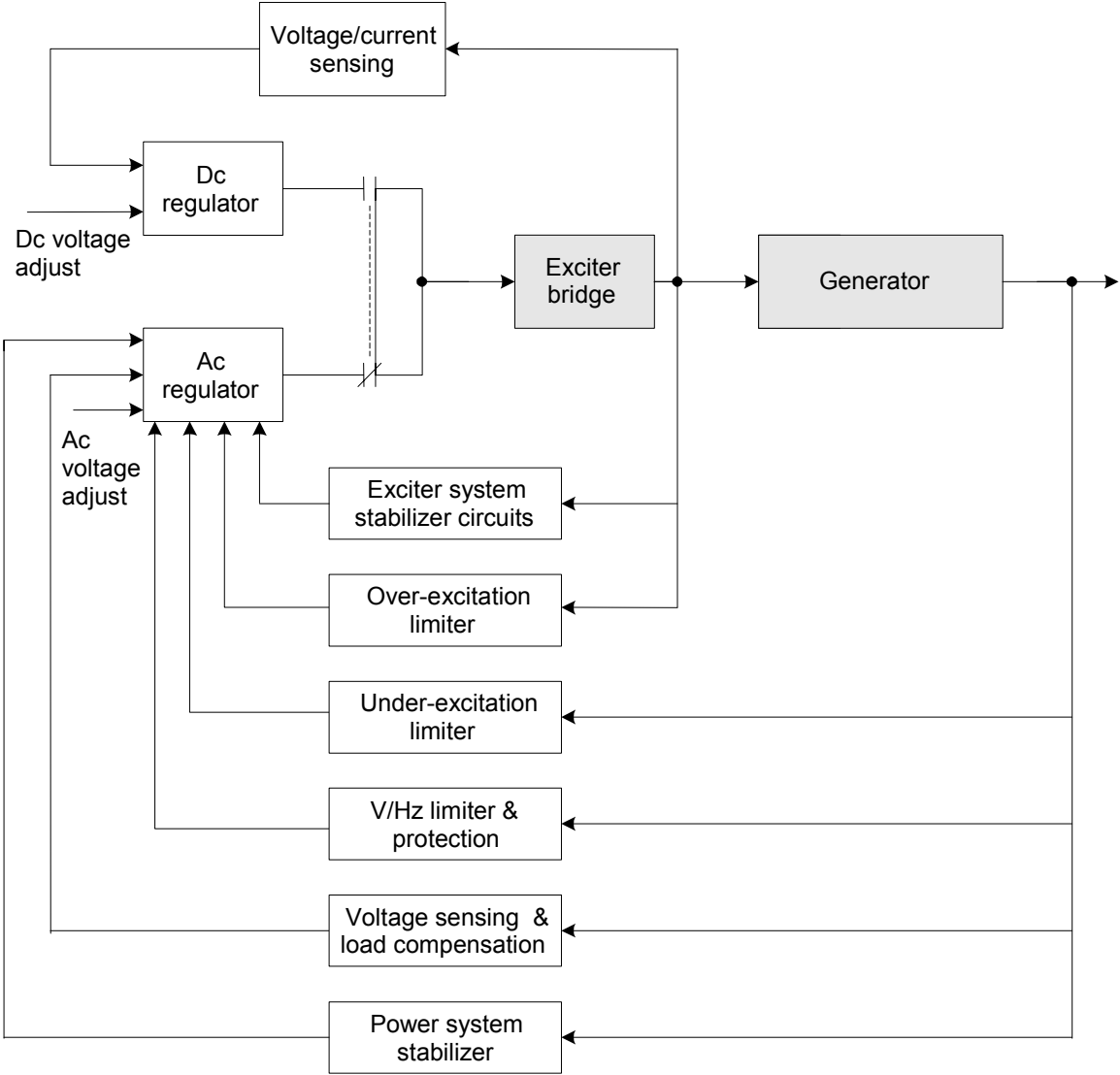

Software Overview Block Diagram

Software Transducers are integral to the high performance of the EX2100 system. The generator PTs and CTs are the source of the control signals needed by the automatic (generator terminal voltage) regulator, most limiters, and protection functions. The system simultaneously samples the ac waveform at high speed and in software uses advanced mathematical algorithms to digitally generate the variables needed. (See the following diagram.)

The output of the software transducer system include the following:

- Generator voltage
- Generator active current (average in phase with watts)
- Generator reactive current (average in phase with reactive power, Vars)
- Generator frequency (current)
- Slip (signal representing the change in the rotor speed)

The transducer system uses the outputs above to calculate the following:

- Generator power and Vars
- Magnitude of generator flux (V/Hz)
- Phase angle and power factor

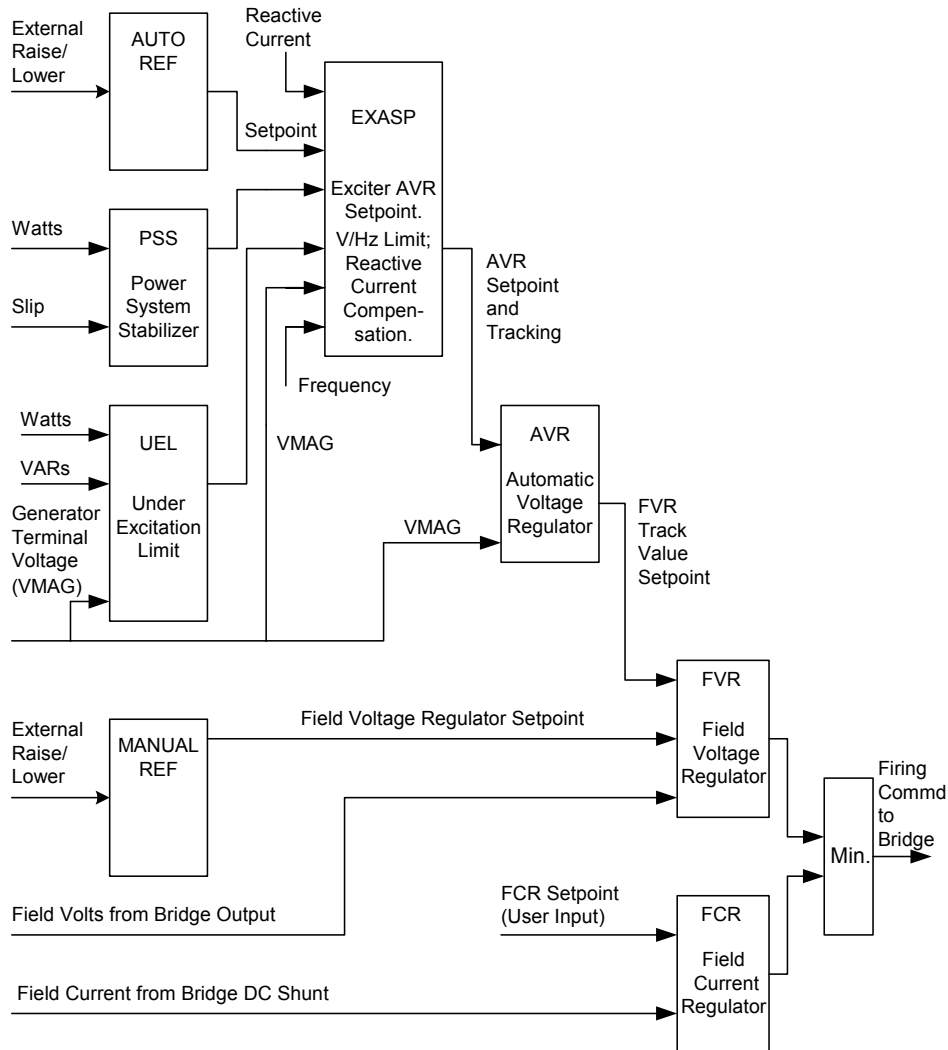

Software Transducer Overview Block Diagram

This block can be configured with upper and lower limits, presets, and up/down ramp times.

This block can be configured with upper and lower limits, presets, and up/down ramp times.

On some applications that require an inner loop regulator, such as compound (voltage and current sourced) exciters and some high ceiling exciters, the manual regulator uses the control output from the AVR as a setpoint input.

Auto Regulator Reference (AUTO REF) generates the auto control (AC) setpoint variable for the automatic voltage regulator (AVR). Operator commands, (raise and lower inputs) come in from direct inputs or over a data link from an HMI operator station or from a plant DCS or remote dispatch system.

Manual Regulator Reference (MANUAL REF) generates the manual setpoint variable for the manual voltage regulator (MVR). Operator commands, (raise and lower inputs) come in from direct inputs or over a data link from an HMI operator station or from a plant DCS or remote dispatch system.

Automatic and Manual Reference Follower (Tracking) are software implemented ramp functions that adjust the non-active regulator output to automatically track the active regulator. That is, when the auto regulator is controlling the generator, the manual regulator tracks, and when the manual regulator is controlling the generator, the auto regulator tracks. This provides for smooth transition when a transfer occurs from one regulator to the other.

Exciter AVR Setpoint (EXASP) combines a number of functions to produce the reference input to the AVR and the variables to support regulator tracking. The reference output from this block is a summation of:

- Stabilizing signal from the power system stabilizer (PSS) block
- Output of the AVR reference block
- Limiter signal from the under excitation limiter (UEL) block
- Output from the reactive current compensation/active reactive current compensation (RCC/ARCC) block
- Combination of frequency and generator voltage to generate the V/Hz limiter signal
- External test signal to support injection of white noise and step test signals

Under Excitation Limiter (UEL) is an auxiliary control to limit the AVR demand for underexcited reactive current. The UEL prevents reductions of the generator field excitation to a level where the small-signal (steady state) stability limit or the stator core end-region heating limit is exceeded. Performance is specified by identifying the region of the limiter action on the generator capability curve.

Reactive Current Compensation (RCC/ARCC) has two modes. When in the reactive current compensation (RCC) mode permits sharing reactive current between paralleled machines. In the active reactive current compensation (ARCC) mode, it enables *line drop* for regulating at some point remote from the generator terminals.

Volts per Hertz Limiter (V/Hz Lim) limits the generator volts per hertz ratio to the programmed setting in the EX2100. This functions uses two inputs from the software transducer, average generator voltage and generator frequency (its V/Hz ratio is configurable). Typically, the generator is considered to be operating acceptably within $\pm 5\%$ of rated terminal voltage at rated frequency.

Automatic Voltage Regulator (AVR) maintains the generator terminal voltage constant over changes in load and operating conditions. The error value (average generator voltage minus the composite reference output from the EXASP block) is the input to a proportional plus integral (PI) regulator with integrator windup protection. In most applications, AVR control output directly controls the firing command generator, which controls the gating of the power bridge SCRs when the AVR is enabled.

Power System Stabilizer (PSS) provides an additional input to the automatic regulator to improve power system dynamic performance. Many different quantities may be used by a PSS, such as shaft speed, frequency, synchronous machine electrical power, accelerating power, or some combination of these signals. The PSS offered in the EX2100 is a multi-input system using a combination of synchronous machine electrical power and internal frequency (which approximates rotor speed) to arrive at a signal proportional to rotor speed. This comes from the integral of accelerating power, but with shaft torsional signals greatly attenuated.

Stator Current Limit (SCL) determines the AVR/VAR control. When the generator stator current exceeds the rated value, the exciter will change from AVR control to a VAR control preset. Once the stator current is less than the rated value, the exciter returns to AVR control.

Manual Regulator (FVR or FCR) controls the generator field voltage or current, letting the generator output voltage. The manual regulator, like the AVR, uses a PI regulator with integrator windup protection and its control output directly controls the firing command generator that controls the gating of the power bridge SCRs when enabled.

The Manual Regulator has two inputs:

Setpoint or reference—For most applications, the manual regulator setpoint or reference input only comes from the MANUAL REF block and is only in control of the power bridge when selected by the operator or after a control transfer. For applications that require an inner loop regulator to be used with the AVR, when the AVR is in control of the generator, the setpoint input comes from the AVR control output.

Generator field feedback (indicates the type of manual regulator)—Field Voltage Regulator (FVR) is the typical manual regulator supplied on most applications and uses the generator field voltage as the feedback input. While FVR's do permit the current to vary as a function of the field resistance, GE has selected the FVR as its standard manual regulator to make the manual regulator completely independent from the over excitation limiter.

Field Current Regulator (FCR) is a special application of the manual regulator and uses the generator field current as the feedback input. While it does regulate constant field current over varying field temperature, GE has not selected the FCR as its standard manual regulator because it inhibits the signal independence from the over excitation limiter.

Over-excitation Limiter (OEL) protects the generator field from damage by events that require abnormally high field currents. These high currents, over an extended time, can overheat the field and cause damage. Generator fields are designed to ANSI Standard C50.13, which specify the overvoltage as a function of time that the field is designed to follow. This standard uses curves to describe the field overheating as a function of time and current. The OEL design approximates the curve of field voltage versus time.

The OEL interfaces directly with the power bridge firing command generator, therefore it can protect the generator field from damage in either automatic or manual regulator mode. The function is not active under normal operation conditions. This allows the exciter to respond to any generator fault condition without current limit for a time period of about one second. After this, a two stage current limiter is activated. The first stage normally limits the current to a high value. The thermal load into the field is integrated, using the known heating time constant of the field, until reaching the field limit. At this time, the current limiter transfers to the lower limit. When the event is over, the integrator discharges based on the cooling time constant of the field, which is slower than the heating time constant.

The current limit values are selectable based on the operating mode of the generator. When the generator is offline, the offline limits are used, and when the generator is online, the online limits are used.

The intent of this function is to correlate limiter action to the valid generator capability curves.

Hydrogen Pressure/Temperature Limiter compensates the configuration parameters of key generator limiters and protection functions based on generator cooling. For hydrogen cooled generators, the correct parameter is the internal hydrogen pressure, and for air-cooled generators, it is air temperature. In either case, the exciter uses a 4–20 mA input to capture the parameter.

The three limiters affected by pressure/temperature compensation are:

- Under excitation limiter (UEL)
- Over excitation limiter (OEL)
- Stator current limiter

Entering the parameters of three generator capability curves configures compensation. Sophisticated software in the exciter extrapolates this data into an infinite number of curves needed to translate the present operation condition of the generator into the correct limiter configuration parameters.

Manual Restrictive Limiter limits the under-excited operation of the EX2100 while the manual regulator is selected (FVR or FCR). It also does not allow the manual regulator to track the automatic regulator when the unit is operating below the field voltage limit called for by the manual restrictive limiter.

VAR/PF Control is accomplished by slow ramping of the AVR reference setpoint. The VAR/PF is selected by operator command and the VAR/PF value is controlled using the raise/lower pushbuttons. When the exciter interfaces with a Mark VI turbine control system, this function is typically included in the Mark VI system.

Generator Simulator (GEN SIM) is a detailed generator model that is included as part of the excitation control system software. It can be configured to closely match the operation of the real generator. It can also be used for operator training, and can support the checkout of regulators, limiters, and protection functions while the unit is shut down.

Unit Data Highway Interface (UDH) connects the exciter with the turbine control system, HMI or HMI viewer/data server, and GE Fanuc PLC controls. The UDH is based on EGD protocol. The UDH provides a digital window into the exciter where variables can be monitored and controlled. It also supports the toolbox configuration and maintenance tool for the exciter.

DCS Interface (ModBus RTU) slave data link is supported to interface with customer DCS systems. This link can be based on RS-232C or use TCP/IP support over Ethernet 10baseT hardware. Both commands and data can be supported.

Volts per Hertz Protection (24G) serves as a backup to the V/Hz limiter and can be supported with or without the C (protection) controller. The protection scheme consists of two levels of V/Hz protection. One level is set at 1.10 per unit over V/Hz with an inverse time period, and the other level is set at 1.18 per unit with a two second time period. In operation, this means:

- From 1.0 to 1.10 per unit no alarm or trip occurs
- From 1.10 to, but not exceeding, 1.18 per unit an alarm is activated with trip time inversely proportional to the magnitude of the over volts per hertz
- At 1.18 per unit trip time is 45 seconds (adjustable from 6-60 seconds)
- If over volts per hertz exceeds 1.18 per unit, either initially or during the inverse time period, trip activation occurs in 2 seconds (adjustable from 1.7 to 2.8 seconds)

Both trip and time setpoints are adjustable.

Over-Excitation Protection (OET) is a backup to the over-excitation limiter and can be supported with or without the C (protection) controller. If an over-excitation condition should occur which the limiter cannot correct, then a trip signal is produced. This function approximates the curve of field voltage versus time defined in ANSI Std. C50.13.

Generator Overvoltage Trip (59G) monitors the generator armature voltage and initiates a trip signal upon detecting an unacceptably high voltage.

Potential Transformer Fuse Failure Detection (PTFD) detects loss of PT feedback voltage to the voltage regulator. If the sensing voltage is lost or if it is single-phased, there is a transfer to the manual regulator and an alarm output is provided. If the PPT is fed from an auxiliary bus instead of the generator terminals, then a second set of PT signals must be supplied to independently monitor the generator terminal voltage.

Transfer to Manual Regulator upon Loss of PT detects loss of PT feedback voltage to the ac voltage regulator. If the sensing voltage is lost, the regulator forces its output to ceiling for 0.5 seconds and then transfers to manual. This is distinctly different from the PTFD function, which does not force the regulator to ceiling before transferring.

Loss of Excitation Protection (40) detects a loss of excitation on synchronous machines. It can provide the GE-recommended settings, which require two separate relay characteristics. The function is performed within software code and can accommodate offset settings and two diameter settings. The recommended offset settings are both equal to one-half the machine transient reactance ($X'd/2$). The small diameter setting is equal to 1.0 per unit on the machine base, and the large diameter setting is equal to the machine synchronous reactance (X_d). The small diameter setting has no time delay and the large diameter setting has an adjustable time delay.

Each of the two relay's characteristics (offset, diameter, time delay) are independently adjustable and can be used to initiate a TRIP signal. GE recommends the use of two relay characteristics since there is some concern about the performance of the voltage regulator when it is operating on the *under-excited limit*. The regulator may undershoot while trying to maintain the limit and cause the apparent impedance to momentarily enter the relay characteristic. If only one relay characteristic is used (small diameter), there may be undesired operation as a result of any regulator undershoot. Using the large diameter setting with time delay helps to avoid this problem with undershoot.

EUT is not available in the EX2100 Regulator Control.

Exciter Phase Unbalance (EUT) monitors the secondary voltage from the 3-phase input PPT. If a voltage phase unbalance condition exists, an alarm is generated, and a trip signal is initiated after a time delay.

Offline Over-excitation Protection (OLOT) serves as backup to the over excitation limiter when the generator is offline. If the generator field current exceeds 120% of no-load field current while operating offline, in either the automatic or manual regulator mode, and the limiter can not correct an over-excitation condition, this function will initiate a trip signal after a time delay.

Generator Field Temperature Calculation measures the resistance by dividing the field voltage by the field current. From the known field resistance at 25°C and the linear resistance temperature change in copper, the algorithm calculates operating temperature. An adjustable high temperature alarm output contact is also included.

Testing

The GE Salem facility is ISO-9001 and Ticket certified. Below is a brief description of the quality assurance tests performed on each exciter.

Routine Factory Tests

Each excitation control is subjected to routine factory tests including, but not restricted to, the following:

- Circuit continuity check
- Dielectric (hi-pot) tests in accordance with IEEE standard 421B
- Functional check of all components and devices for proper operation
- Most other electrical parts, such as power supply, transformers, reactors, compensators and similar devices, are tested individually in accordance with applicable ANSI standards or IEEE standards. If, however, the parts are in quantity production and routine tests are made, and such routine tests are in accordance with the above noted standards, individual tests of such parts will not be conducted
- An engineering inspection for conformance to purchaser specs

The transformer tests are in general accordance with ANSI standard C57.91 for dry type transformers and ANSI standard C57.90 for liquid filled transformers. The tests include:

- Resistance measurements by any of the methods described in the applicable ANSI standard
- No-load loss and excitation test
- Applied potential test
- Induced potential test
- Losses and impedance tests
- Ratio tests
- Phase relation test

Customer Witness Tests

All equipment goes through extensive testing with appropriate reviews and sign-offs as described in the section *Routine Factory Tests* above. After that, the customer can select either of two options for a customer witness test.

- **Option A** lets the customer examine the appearance and workmanship of the equipment, then review the engineering and test paperwork. This is a standard service for no additional charge.
- **Option B** lets the customer witness a demonstration of the hardware and software. This is an added-cost item to the customer.

Customers who desire some form of witness test other than Option A or Option B must contact GE Salem upon placing their order to discuss the feasibility and cost of conducting such a test.

Our customers are always welcome to visit the Salem factory to see how their equipment is engineered and manufactured.

Option A

This normal production inspection, performed immediately prior to shipment, verifies the mechanical integrity, conformance to special purchaser hardware requirements, appearance, and design completeness of the enclosure. The purchaser can elect to participate in this inspection at no charge. This inspection lasts approximately two hours, and includes:

- Inspection of appearance and mechanical integrity
- Review for completion:
 - Test instructions
 - Test log
 - Test defect record
 - Check engineering log
 - Inspection defect records
 - Shortages
- Audit *T* check (for example, labeling/nomenclature)
- *As-shipped* prints
- Purchaser special requirements

The customer usually inspects the hardware the day before the unit is sent to shipping. At this point, the unit will have been completely tested and inspected. The customer can inspect the unit to ensure that its appearance meets his expectation before it is shipped. Generally, the customer reviews the quality of workmanship, looking at paint, wiring, crimping, assembly, etc. The duration of this witness point is two hours.

The second part of this option is a review with the engineer. The customer can review all paperwork relevant to the engineering and testing of the requisition. This would include the elementary, I/O list, alarm list, layouts, outlines, test sign-off sheets, and such. This documentation provides the basis for certification that the customer's hardware and software went through the proper engineering, verification, and test processes. The duration of this witness point is approximately two hours.

The customer should advise GE Salem eight weeks prior to shipment of their intent to visit the factory to inspect his equipment. GE will inform the customer two weeks prior to the inspection date so that the customer can make travel arrangements. There is no additional cost associated with this option.

Option B

This customer witness option consists of two demonstrations:

- Hardware demonstration
- Software demonstration

The *hardware* demonstration is an audit of those tests previously performed as described in the section *Routine Factory Tests*. The duration of this witness demonstration is typically two to four hours.

For the *software* demonstration, the customer's application software is downloaded to a simulator panel at a convenient workstation area (not the customer's equipment) to verify its integrity, functionality, and conformance to the specifications. The simulator panel uses the same printed wiring boards and software that are used in the customer's equipment to model the specific application, or a typical generator and its field.

The software simulates a normal startup and control sequence:

- emulating the necessary contactor(s) and relays
- checking feedback echoes for closing verifications
- activating regulators in both the manual and automatic modes
- displaying any faults

The engineer uses the simulation method to check out the integrity of the system by also exercising any special functions. The duration of this witness demonstration is approximately four hours.

Option B, if selected, should be included as part of the initial purchase order. If a customer decides to purchase this option after the initial ordering drawing release, an amendment to the PO will be required. If option B was not initially purchased, then notification of a change order is required at least eight weeks prior to shipment of the equipment. GE will inform the customer two weeks prior to the test date so that the customer can make travel arrangements. There is an additional cost associated with this customer witness point.

Standards Supported

Safety

- UL508A Safety Standard Industrial Control Equipment
- CAN/CSA 22.2 No. 14 Industrial Control Equipment
- UL 796 Printed Circuit Boards
- ANSI IPC guidelines
- ANSI IPC/EIA guidelines

Electromagnetic Compatibility (EMC) Directive 89/336/EEC

- EN50081-2 General Emission Standard
 - EN 55011:1991 ISM equipment emissions (CISPR 11)
- EN 50082-2:1994 Generic Immunity Industrial Environment
 - EN 61000-4-2 Electrostatic Discharge Susceptibility
 - ENV 50140:1993 Radiated RF Immunity
 - EN 50141 Conducted RF Immunity
 - EN 61000-4-4 Electrical Fast Transient Susceptibility
 - EN 61000-4-5 Surge Immunity

CE – Low Voltage Directive 72/23/EEC

- EN 50178 Electronic equipment for use in power installation 1995
- EN 60439-1 (Panel Program)

CE – Machinery Directive 89/392/EEC

- EN 60204-1 Electrical Equipment for Machines
- EN 292-1 Basic Terminology, Methodology
- EN 954-1 General Design Principals

IEEE

- 421.1 Standard Definitions for Excitation Systems for Synchronous Machines
- 421.2 Guide for Identification, Testing, and Evaluation of the Dynamic Performance of Excitation Control Systems
- 421.3 High-Potential Test Requirements for Excitation Systems for Synchronous Machines
- 421.4 Guide for the preparation of Excitation Systems Specifications
- 421.5 Recommended Practice for Excitation Systems for Power Stability Studies
- C57.12.01 General Requirements for Dry-Typ Distribution & Power Transformers including those with Solid Cast and/or Resin-Encapsulated Windings
- C57.110 Recommended Practice for Establishing Transformer Capability when Supplying Non-Sinusoidal Load Currents
- C57.116 Guide for Transformers Directly Connected to Generators
- C37.90.1 Surge Withstand Capability (SWC) tests for Protective Relays & Relay Systems
- C57.18.10 Practices and Requirements for Semiconductor Power Rectifier Transformers

Seismic - Universal Building Code (UBC) – Seismic Code section 2312 Zone 4



GE Industrial Systems