

DCS Thyristor Power Converters for DC Drive Systems 25 to 5150 A

Service Manual

DCS 500
DCS 600

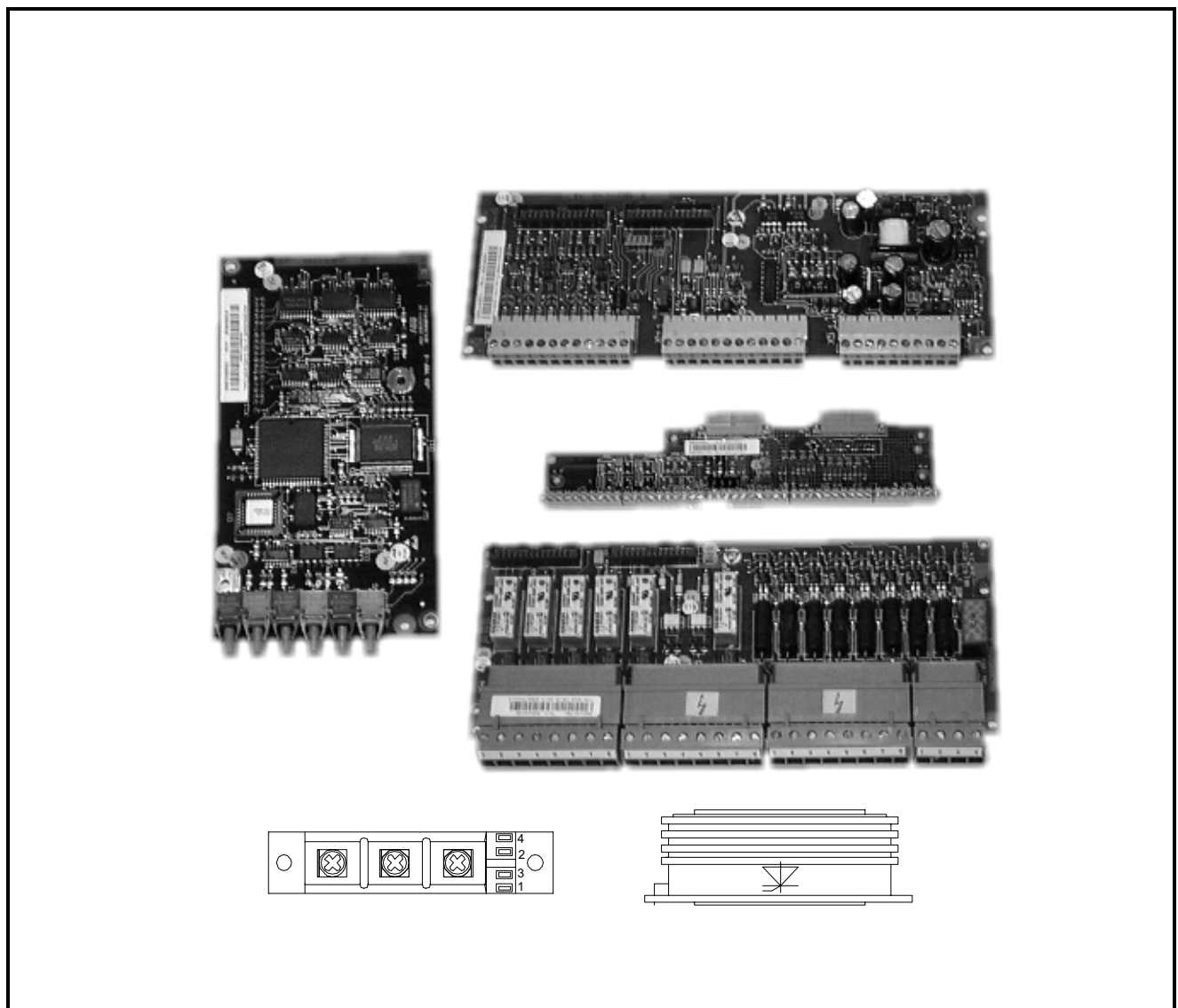

How to use the DCS Documentation System

The matrix below indicates all available product documentation and its corresponding order numbers on its left columns as well as all existing DC Drive systems on its top rows. System descriptions, Technical data and Operating instructions (as far as they are available for the corresponding drive) are the basic documents and will be delivered together with each drive. All other documentation has to be ordered separately.

DC drive systems			System Drive						Standard Drive						Rebuild															
			Cubicle			Module			Cubicle			Module																		
			DCA 600	DCA 620				DCS/DCF 600 MultiDrive	DCS 600 Crane Drive			DCA 500 / DCA 520	DCS 500 Easy Drive	DCS 400 Easy Drive	DCS 400	DCS/DCF 500B	DCE 400	DCR												
			Product documentation																											
System description			Language	Volume																										
3ADW000066			EN, DE, FR	II D									x	x																
3ADW000072			EN, DE	II F	x	x		x																						
3ADW000121 ①			EN	II F1	x	x																								
3ADW000095 (Manual) ②			EN, DE, FR, IT, SP	II K								x																		
3ADW000139			EN	II F	x				x																					
3ADW000071 (Flyer)			EN, DE									x																		
3ADW000152			EN, DE, FR, IT, SP																											
3ADW000173 (Flyer)			EN										x																	
Technical Data			Language	Volume																										
3ADW000165			EN	III				x	x																					
Operating Instructions			Language	Volume																										
3ADW000055			EN, DE, FR, SP	IV A								x	x																	
3ADW000080			EN, DE	IV F	x	x		x																						
3ADW000091 (Installation)			EN, DE	IV F1	x	x						x		x																
Software description			Language	Volume																										
3ADW000078			EN	V D1									x	x																
3ADW000076			EN	V F	x	x		x																						
3AST000953 ③			EN		x				x																					
Tools			Language	Volume																										
3AFE6117875 CMT/DCS500			EN	-									x	x																
EN 5926915-1 GAD			EN	-									x	x																
3ADW000048 (Application blocks)			EN	V A2																										
3AFY61296123 Drive Window			EN	-	x	x		x	x																					
Service Instructions			Language	Volume																										
3ADW000093			EN, DE	VI A	x	x		x	x				x	x																
3ADW000131			EN	VI K										x													x			
Fieldbus			Language	Volume																										
3ADW000086			EN	-									x	x																
3ADW000097			EN	-	x	x		x	x																					
Others			Language	Volume																										
3ADW000115 12-Pulse operation			EN	VIII F2	x						x																			
3ADW000092 Rebuild manual			EN	XI H1								x																		
3ADW000128 Paralleling DCS Conv.			EN	VIII D1	x						x																			
3ADW000040 12-Puls operation			EN, DE	VIII A2									x																	

available only for: DCS 500B / 600 drive systems

Status: 25. March 2002
 ① Covers information of Technical data
 ② Covers information of Technical data, Operating Instructions, Software Description
 ③ Covers information of Operating Instructions, Software Description

Note: For clearness the type designation in this brochure is shown in the following way:

Designation	is valid for
DCS 500	DCS 500 DCS 500B
DCS 600	DCS 600

Thyristor Power Converters

Series
DCS 500 / DCS 500B
DCS 600
25 to 5150 A

Service Manual

Code: 3ADW 000 093 R0601 Rev F

S_M_E_F.DOC

EFFECTIVE: Jul. 4th, 2002
SUPERSEDES: Rev E Oct. 26th, 2001

Safety Instructions

Overview

This chapter contains safety instructions which must be complied with during installation, operation and maintenance of the power converters series **DCS 500 or DCS 600**. If these instructions are not complied with, this may result in injuries (perhaps even with fatal) or in damage to the power converter, the motor and the driven machine. Before starting with any work whatsoever at or with this unit, you must read the information given in this chapter.

Warnings

Warnings provide information on states which if the specified procedure for the state concerned is not meticulously complied with may result in a serious error, in major damage to the unit, in injury to persons and even in death.

They are identified by the following symbols:



Danger: High Voltage! This symbol warns you of high voltages which may result in injuries to persons and/or damage to equipment. Where appropriate, the text printed adjacent to this symbol describes how risks of this kind may be avoided.

- All electrical installation and maintenance work on the thyristor power converter must be carried out by properly qualified staff who have been thoroughly trained in electrical engineering.
- The thyristor power converter and its adjacent units must be properly earthed by qualified professionals.
- You must NEVER perform any work on the thyristor power converter while it is still switched on. First switch the unit off, use a measuring instrument to make absolutely sure that the power converter has really been de-energized, and only then you may start with the work concerned.
- Due to external control circuits, there may be dangerously high voltages present at the thyristor power converter even after the line voltage has been switched off. So always work at the unit with appropriate caution! Non-compliance with these instructions may result in injury (or even death!).



General warning: this symbol warns you of non-electrical risks and dangers which may result in serious or even fatal injury to persons and/or in damage to equipment. Where appropriate, the text printed adjacent to this symbol describes how risks of this kind may be avoided.

- When thyristor power converters are in use, the electric motors, power transmission elements and the driven machines are working in an extended operating range, which means they have to cope with a relatively high loading.
- You should have made sure that all units, devices and appliances used are actually suitable for this higher loading.
- If you have to operate the thyristor power converter at a rated motor voltage and/or a rated motor current significantly below the figures stated in the thyristor power converter's output data, you must take appropriate precautionary measures to protect the unit against overspeed, overload, breakage, etc., by modifying the software or hardware appropriately.
- For insulation testing, you must disconnect all cables from the thyristor power converter. You should avoid operating your unit at values other than the rated data. Non-compliance with these instructions may cause lasting damage to the thyristor power converter.
- The thyristor power converter possesses a number of automatic reset functions. When these functions are executed, the unit will be reset after an error and will then resume operation. These functions should not be used if other units and devices are not suitable for an operating mode of this kind, or if their use might entail dangerous situations.



Warning of electrostatic discharge: this symbol warns you against electrostatic discharges which may damage the unit. Where appropriate, the text printed next to this symbol describes how a risk of this kind may be avoided.

Notes

Notes supply information on states requiring particular attention, or indicate that additional information is available on a specific topic. For this purpose, the following symbols are used:

CAUTION! **Cautions** are designed to draw your attention to a particular state of affairs.

Note A **note** contains or refers you to additional information available on the particular topic concerned.

Mains connection

You can use a switch disconnecter (with fuses) in the power supply of the thyristor power converter to disconnect the electrical components of the unit from the power supply for installation and maintenance work. The type of disconnecter used must be a switch disconnecter as per EN 60947-3, Class B, so as to comply with EU regulations, or a circuit-breaker type which switches off the load circuit by means of an auxiliary contact causing the breaker's main contacts to open. The mains disconnecter must be locked in its "OPEN" position during any installation and maintenance work.

EMERGENCY STOP buttons

EMERGENCY STOP buttons must be installed at each control desk and at all other control panels requiring an emergency stop function. Pressing the STOP button on the CDP 31x control panel of the thyristor power converter will neither cause an emergency motor stop, nor will the drive be disconnected from any dangerous potential.

To avoid unintentional operating states, or to shut the unit down in case of any imminent danger according to the standards in the safety instructions it is **not** sufficient to **merely** shut down the drive via signals „RUN“, „drive OFF“ or „Emergency Stop“ respectively „control panel“ or „PC tool“.

Intended use

The operating instructions cannot take into consideration every possible case of configuration, operation or maintenance. Thus, they mainly give such advice only, which is required by qualified personnel for normal operation of the machines and devices in industrial installations.

If in special cases the electrical machines and devices are intended for use in non-industrial installations - which may require stricter safety regulations (e.g. protection against contact by children or similar) -, these additional safety measures for the installation must be provided by the customer during assembly.

Safety Instructions

Contents

VI A SERVICE MANUAL

Safety Instructions

Chapter 1 - Introduction

How to use this manual.....	1-1
Contents of this manual	1-1
Target group	1-2
Associated publications.....	1-2
Storage and transport	1-2
Rating plate and type code	1-2

Chapter 2 - Fault Tracing Thyristors

How to detect, if a thyristor is faulty.....	2-1
A fuse is blown	2-1
Ripple monitor	2-1
How to find a faulty thyristor.....	2-2
Converters size C1 and C2/C2b (25...1000 A).....	2-2
Blown fuses	2-2
Converters size A5, C3 and C4 (900...5150 A)	2-3
Blown fuses	2-3
Ripple monitor	2-3

Chapter 3 - Handling the Semiconductors

General Instruction how to handle the Semiconductors	3-1
--	-----

Chapter 4 - Exchange of Thyristors for Sizes C1/C2/C2b

Installation of thyristor modules in converters size C1/C2/C2b (25...1000 A)	4-1
Required Tools	4-1
Remove faulty thyristor modules.....	4-1
Install new thyristor modules.....	4-2
Thyristor module location.....	4-3
Module terminals	4-8

Chapter 5 - Exchange of Thyristors for Size A5

Installation of "Disc Type" thyristor in converters size A5 (900...2000 A).....	5-1
Required Tools	5-1
Find faulty thyristor	5-2
Remove faulty thyristor	5-3
Install new thyristor	5-4

Chapter 6 - Exchange of Thyristors for Size C3

Installation of "Disc Type" thyristor in converters size C3 (900...2000 A)	6-1
Required Tools	6-1
Remove faulty thyristor	6-2
Find faulty thyristor	6-2

Contents

Install new thyristor 6-3
Fasten the clamp 6-3

Chapter 7 - Exchange of Thyristors for Size C4

Installation of "Disc Type" thyristor in converters size C4 (2050...5150 A) 7-1
Required Tools 7-1
Find faulty thyristor 7-2
Install new thyristor 7-3

Chapter 8 - Compatibility of SDCS-PIN-2 boards

Description of SDCS-PIN-20xB boards 8-1
Hardware coding 8-1
Snubber circuit 8-1
Compatibility of SDCS-PIN-20x boards 8-2
Compatibility of SDCS-PIN-20x and SDCS-PIN-2x boards 8-2
Change SDCS-PIN-2x boards 8-3

Chapter 9 - Preventive Maintenance

Recommended regular maintenance 9-1
Air Filters 9-1
Cooling air pressure switch in converter modules type C4 9-1
Fan 9-1
Heatsink 9-1
Internal high current connections in converters type C4 9-2
Relays and electrical connections 9-2

Appendix A - Spare Parts List

Chapter 1 - Introduction

How to use this manual

The purpose of this service manual is to provide detailed information on how to service power converters from the **DCS 500** or **DCS 600** series.

Note: If it is not mentioned explicitly all details given in this Service Manual will be valid for both, series **DCS 500** and series **DCS 600**!

Contents of this manual

Chapter 1 - Introduction

This chapter informs about the contents and the use of this manual as well as the boundary conditions applying and the thyristor power converter rating plate.

Chapter 2 - Fault Tracing Thyristors

This chapter describes how to detect and select a faulty thyristor.

Chapter 3 - Handling the Semiconductors

This chapter describes the handling of thyristors and thyristor modules.

Chapter 4 - Exchange of Thyristors of Sizes C1/C2/C2b

This chapter describes the exchange of thyristors in converters sizes C1/C2.

Chapter 5 - Exchange of Thyristors of Size A5

This chapter describes the exchange of thyristors in converters size A5.

Chapter 6 - Exchange of Thyristors of Size C3

This chapter describes the exchange of thyristors in converters size C3.

Chapter 7 - Exchange of Thyristors of Size C4

This chapter describes the exchange of thyristors in converters size C4.

Chapter 8 - Compatibility of SDCS-PIN-2 boards

This chapter describes the compatibility, utilization and removing/mounting of power interface boards PIN-2x/PIN-20x.

Chapter 9 - Preventive Maintenance

This chapter describes the measures for preventive maintenance of the thyristor converters.

Appendix A - Spare Parts list

The *Appendix A* contains the spare parts list of the converters.

Target group

This manual is designed to help those responsible for planning, installing, starting up and servicing the thyristor power converter.

These people should possess

- basic knowledge of physics and electrical engineering, electrical wiring principles, components and symbols used in electrical engineering, and
- basic experience with DC drives and products.

Associated publications

The **DCS 500 or DCS 600** documentation includes the following:

Technical Data DCS Thyristor Power Converter

Operating Instructions

System Description DCS 500 and DCS 500B

System Description DCS 600

CAUTION! The thyristor power converter weighs quite a lot and should therefore not be held by the front cover. Please put the unit down only on its back (sizes C1 to C3). Always use due care when handling the unit, so as to avoid injuries or damage.

Storage and transport

If the unit had been in storage prior to installation or is transported to another location, care must be taken to ensure that the environmental conditions are complied with (*see "System Descriptions"*).

Rating plate and type code

For purposes of identification, each thyristor power converter is fitted with rating plates, stating the type code and the serial number, which serve for each unit's individual identification.

The type code contains information on the characteristics and the configuration of the unit.

	ABB Automation Products GmbH			Made in Germany	
	Type: DCS502B0820-51-21P0000-0000000	U_1	3 ~ 500 V	U_2	580 V d.c.
	Ser No: 0003109B2261775	I_1	669 A	I_2	820 A
		f_1	50/60 Hz	I_{30}	900 A

Figure 1-1 Example of a rating plate

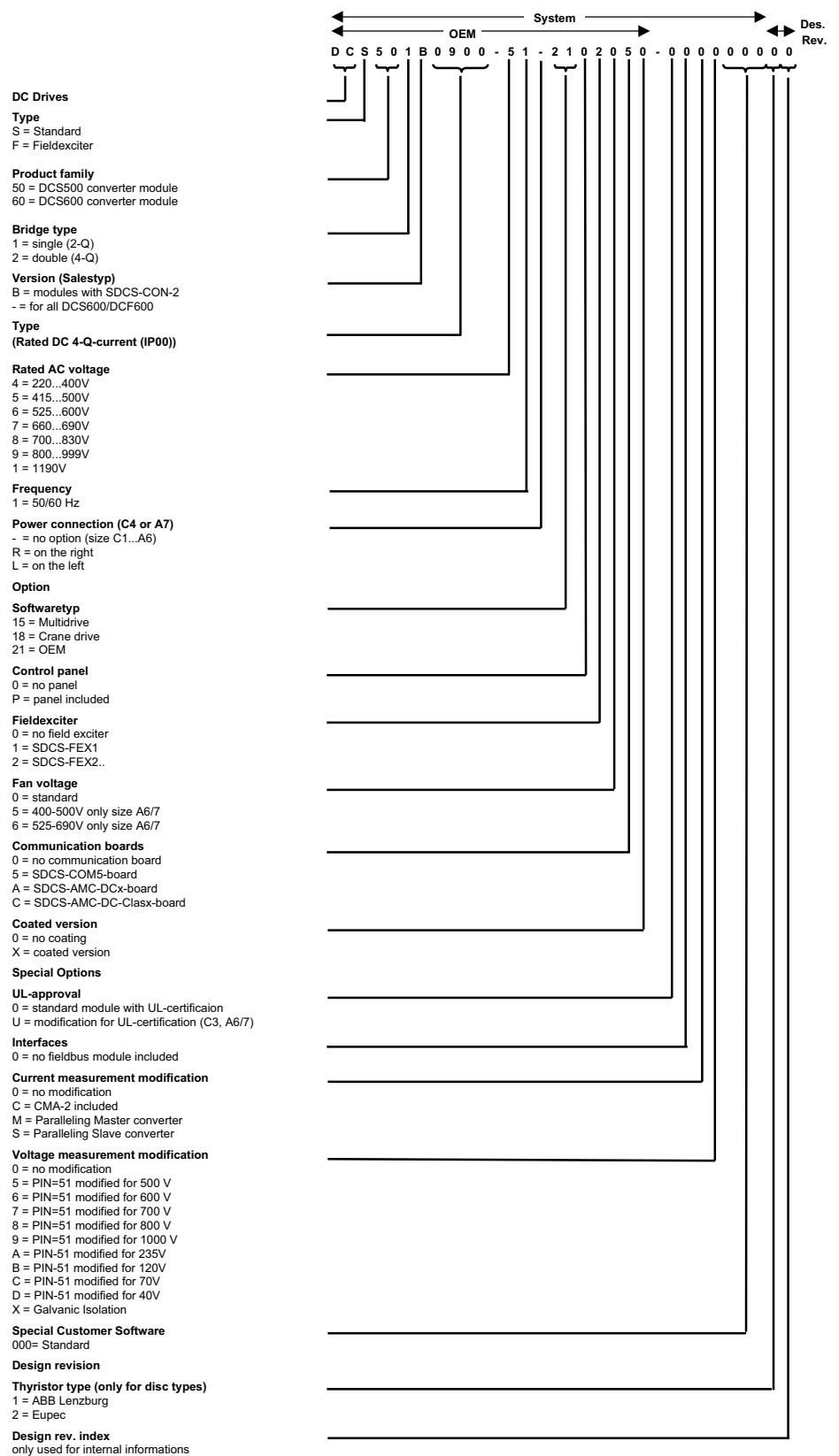

Figure 1-2 Type code

The technical data and specifications are valid as of going to press.
ABB reserves the right to make subsequent alterations.

If you have any questions concerning your drive system, please
contact your local ABB agent.

Chapter 2 - Fault Tracing Thyristors

How to detect, if a thyristor is faulty

Thyristor problems can be noticed by two ways:

A fuse is blown

This is an indication, that a strong overcurrent has happened due to one of the following reasons:

- An internal short circuit between the phases (line side) because of a defect thyristor (short circuit inside a thyristor from anode to cathode).
- An internal short circuit between the phases (line side) because of circulating current in a 4-Q converter (malfunction of the control electronics, no thyristor defect).
- An external short circuit at the DC terminals of the converter without sufficient impedance.
- A commutation fault during inverting mode operation (active braking with high current, high EMF and with low AC voltage).

Ripple monitor

The ripple monitor indicates, that the ripple of the DC current is much higher than normal. In such a case, most often one thyristor does not work. It's missing current contribution causes a deep dip in the direct current.

The structure of the current loop, the current controller will force the other thyristors to compensate the dip by a certain overcurrent in order to keep the average current constant. Such a compensation results in a ripple monitoring fault during motoring mode operation with $\alpha \leq 90^\circ$.

During braking or inverting mode operation most often fuses are blown.

The reason for a currentless thyristor may be:

- A fuse has disconnected one of the six thyristors. This is possible only for converters with 900...5150 A (six internal branch fuses). A converter with three external fuses stops working completely at once when one of the three AC input fuses interrupts a phase input of the converter.
- A thyristor does not get firing pulses.
- The current controller may be totally mismatched to the DC load.
- The AC mains network is causing that fault message. In this case, asymmetrical phase shift, uneven phase voltage or critical designed power factor correction equipment or harmonic reduction equipment can be the reason.

How to find a faulty thyristor

If a blown fuse is suspected in the converter, the problem is caused most often by a faulty thyristor. To make sure, that a thyristor is the reason and needs to be exchanged fault tracing must be done in two different ways, depending on the size of the converter.



In general, make sure, that all safety instructions, given within this manual or within the safety instructions, related to the machine or the application itself, are obeyed.

Converters size C1 and C2/C2b (25...1000 A)

These converters require semiconductor fuses in the 3 AC lines.

- The converter must be disconnected from the mains.
- One motor armature cable should be disconnected from the converter.

Blown fuses

- Using the OHM function of a normal multimeter, measurements must be made from each AC terminal to each DC terminal (U1 to C1, V1 to C1, W1 to C1, U1 to D1, V1 to D1 and W1 to D1; see *Figure 4-3*). Normally, every measurement should show high resistance ($> 1 \text{ k}\Omega$). Target: find a short circuit, indicated by low resistance ($< 1 \Omega$) (destroyed thyristor).
- If the converter is designed with half-bridge thyristor modules, then a module consists of two antiparallel thyristors. In this case it is sufficient to know which thyristor pair or module has a defective thyristor because the complete module must be replaced.
- After a thyristor module is replaced, the above mentioned measurement should be done another time to make sure that all faulty thyristors have been detected!

Note

The RC circuit could also cause 0Ω result for a short time.

The measurement, showing less resistance than 1Ω should be made a second time with test leads applied to the terminals with the opposite polarity; if this measurement shows the same result, one or two thyristors located in that path are faulty; they need to be replaced.

**Converters size A5,
C3 and C4
(900...5150 A)**

These converters are equipped with fuses in the branches of the power part.

- The converter must be disconnected from the mains.

Blown fuses

- In case of a blown fuse, the faulty thyristor or the faulty pair of thyristors are already isolated at one side from the others and therefore the faulty branch is known (see *Figure 4-4*).
- The OHM test should be performed, when the thyristor is still clamped. Outside the converter a special thyristor clamping device is needed.
- For 4-Q converters with antiparallel thyristors:
The selection of a forward or reverse thyristor is done during the disassembly. Continue with related chapter 5, 6 or 7
Find faulty thyristor
- After a thyristor was replaced, the OHM test should be done another time to make sure that all faulty thyristors have been detected! If the motor is still connected to the converter the result of the measurement may be wrong.

Ripple monitor

If the ripple monitor fault occurred, the fault tracing must be adapted to the reasons listed before:

- Check the fuses and the thyristors, according to the statements before.
- If the power section seems to be ok, but still one or more thyristors don't take current, something went wrong in between the firing pulse generation and the thyristor's gate; in this case check:
 - Is a firing pulse present on the primary side of the firing pulse transformer?
 - Is a firing pulse present on the secondary side of the firing pulse transformer?
 - Is the firing pulse transferred to the gate of the thyristor? Are there all electrical connections still healthy?
 - Can the thyristor be fired with the applied firing pulse? Is the pulse form of the firing pulse identical at all measuring positions?
- Check the settings of the current controller.
- Check the AC mains network by taking recordings of the line voltage and current at all 3 phases at the same time.

Chapter 3 - Handling the Semiconductors

General Instruction how to handle the Semiconductors

Thyristor modules, busbars and fuses have to be mounted with the correct torque using a torque screw driver or torque wrench. Disc type thyristors in converters size C3 (900...2000 A DC) are normally mounted using a dial gauge, for repair reasons, they can be mounted using a torque wrench.

In converters sizes A5 (900...2000 A DC) and C4 (2050...5150 A DC) the mounting force is indicated by an indicating spring welded to the mounting clamp, which is inside the unit.

Always mark suspected damaged components clearly after removing them from the circuit, to avoid confusion with "good" components.

When removing a damaged semiconductor, write down how and where it was installed (direction, location and connected gate leads).

Check that the new and old component have the same type designation or that the new component can replace the old one. A semiconductor can be replaced by different compatible semiconductor according to the codes in the manufacturers' table.

Semiconductor components are high-precision products. All unnecessary used tools and objects might damage the easily dented and scratched surfaces of the semiconductors.

1. Keep new semiconductors as long as possible in their original packages.
2. Use protective gloves if possible.
3. Clean work area and hands frequently.
4. Use good illumination.

Chapter 4 - Exchange of Thyristors for Sizes C1/C2/C2b

Installation of thyristor modules in converters size C1/C2/C2b (25...1000 A)

All DCS 500 and DCS 600 size C1/C2/C2b are equipped with thyristor **modules**.

In order to keep the operating temperature of the semiconductor module low, the joint between the heat sink and the module should have a good heat conducting ability. The electrical conductivity of the connectors must also be good. For this reason the following instructions must be observed with particular care.

Required Tools

Special tools or material needed in addition to standard tools for the exchange of thyristor modules:

- torque spanner: mounting torques for thyristor module to heat sink and electrical connections see table "Nominal mounting torques for thyristor modules" in this chapter;
- screws are metric type; use appropriate nuts
- tissue paper / solvent
- thermal joint compound: type **BERULUB FZ1 E3** (grease)

Manufacturer: Carl Bechem GmbH, 58089 Hagen
ABB Service: GHSN 390 011 P 0051



Before the work is started, disconnect the converter from the power supply completely, then check the voltage free condition and make sure, everything is located in an electrical and mechanical safe condition!

Remove faulty thyristor modules

- Tilt out the electronics casing.
- Remove the gate leads from the faulty thyristor module and mark the position of the trigger connections on the cable.
- Remove only as many parts as is needed around the faulty module. If the current transformer must be removed, mark the position and the connections!
- Remove the faulty thyristor module and mark it.

Install new thyristor modules

- Remove old thermal joint compound (grease) from the heat sink. Preparation of the heat sink: if the area is clean, spread out the heat-conducting compound with a rubber spatula or by hand. If the area is dirty, clean the heat sink surface with tissue paper. Clean the mounting surfaces with an appropriate solvent (e.g. ethanol).
- Apply a thin coat of thermal joint compound to the new module. Spread the thermal joint compound evenly by moving the module forward and backward on the heat sink.
- Tighten the clamping screws by hand until the screw heads touch the bottom of the module. Then tighten the screws to 2.5 Nm torque. If the module is mounted using four screws, tighten the screws crosswise.
- Tighten the screws to nominal torque (see Table below).
- Reinstall the busbars; make sure, the correct torque is applied and reconnect all cables.

Thyristor module		Nominal mounting torques	
Size	Type	Electrical connections	Module to heat sink
20 mm block	SKKT.....	3 Nm	5 Nm
34 mm block	SKKT.....	5 Nm	5 Nm
34 mm block	TT.....	6 Nm	6 Nm
50 mm block	SKKT.....	9 Nm	5 Nm
50 mm block	TT.....	12 Nm	6 Nm
50 mm block (single thyrist.)	SKET.....	9 Nm	5 Nm
50 mm block (single thyrist.)	TZ.....	12 Nm	6 Nm
60 mm block	TT425/TT570	12 Nm	6 Nm

Table 4-1 Nominal mounting torques for thyristor modules

Thyristor module location

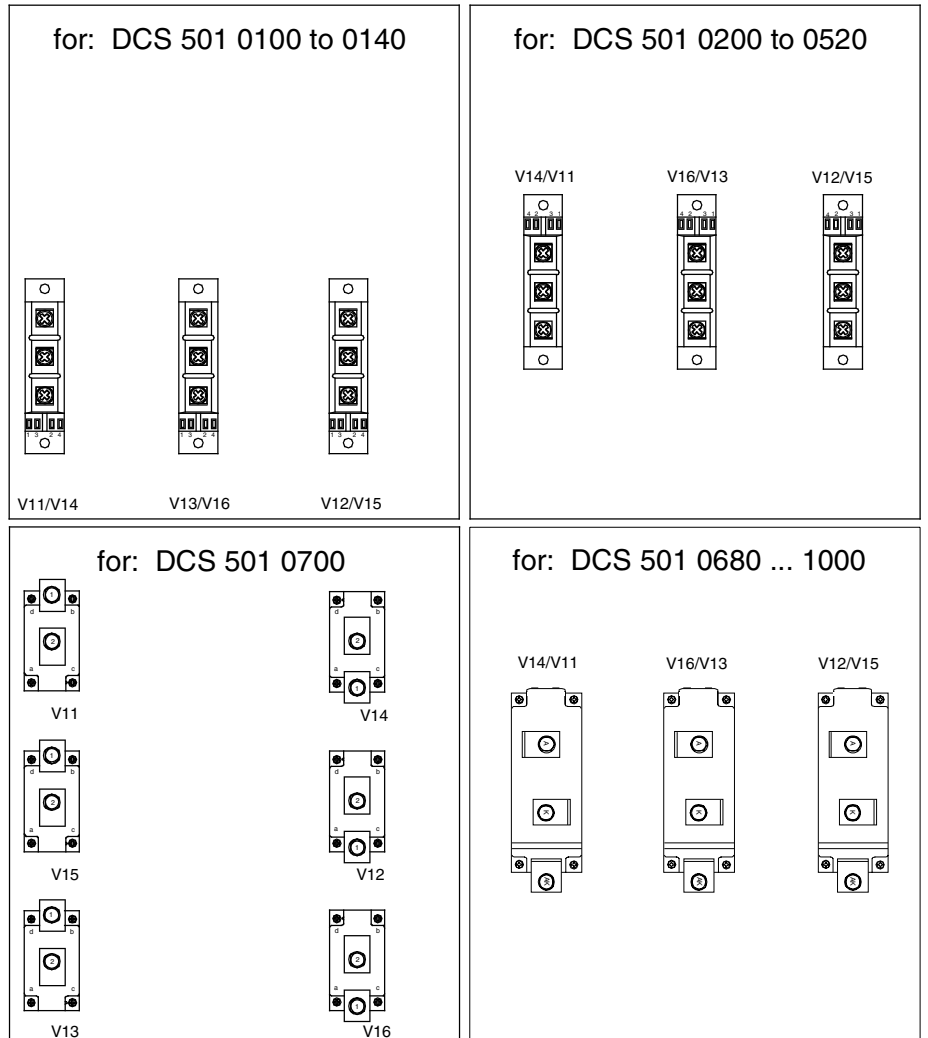

Figure 4-1 Location of thyristor modules in DCS 501/601-0100...1000 units

Note: This drawing is only for showing the location of the modules, the module size can be different!

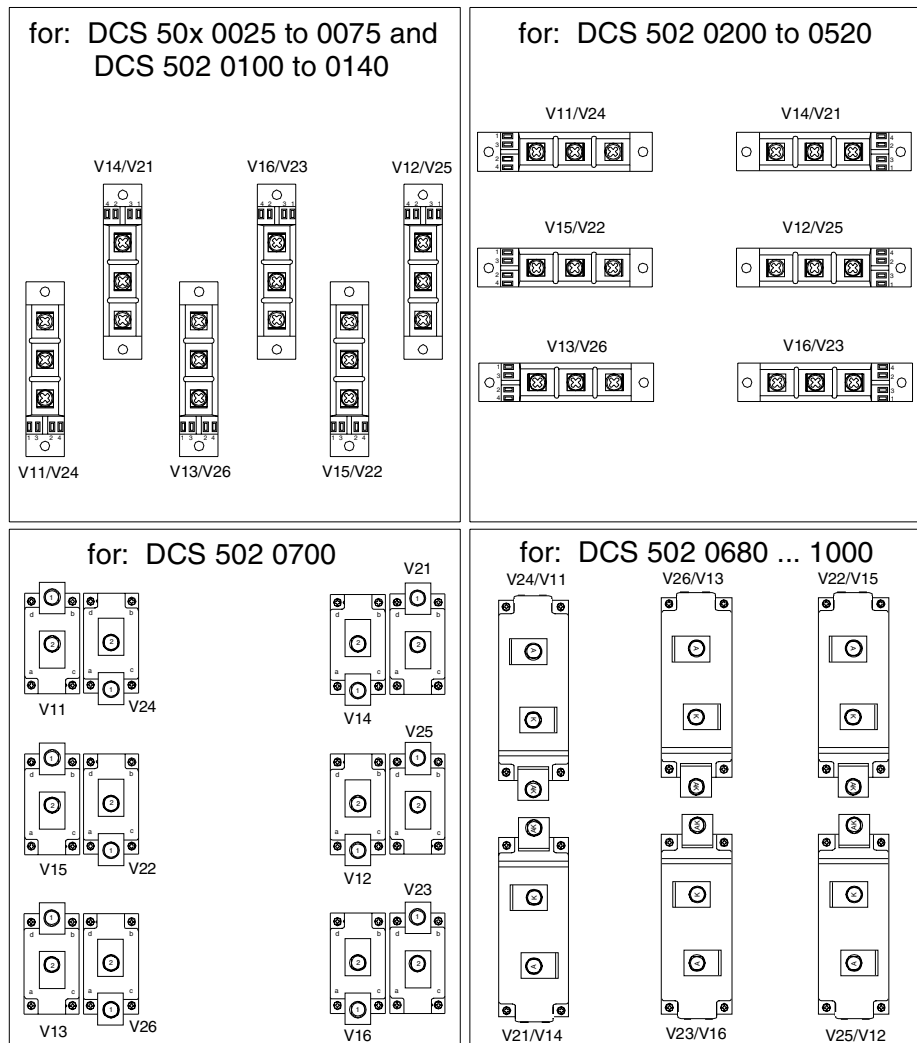
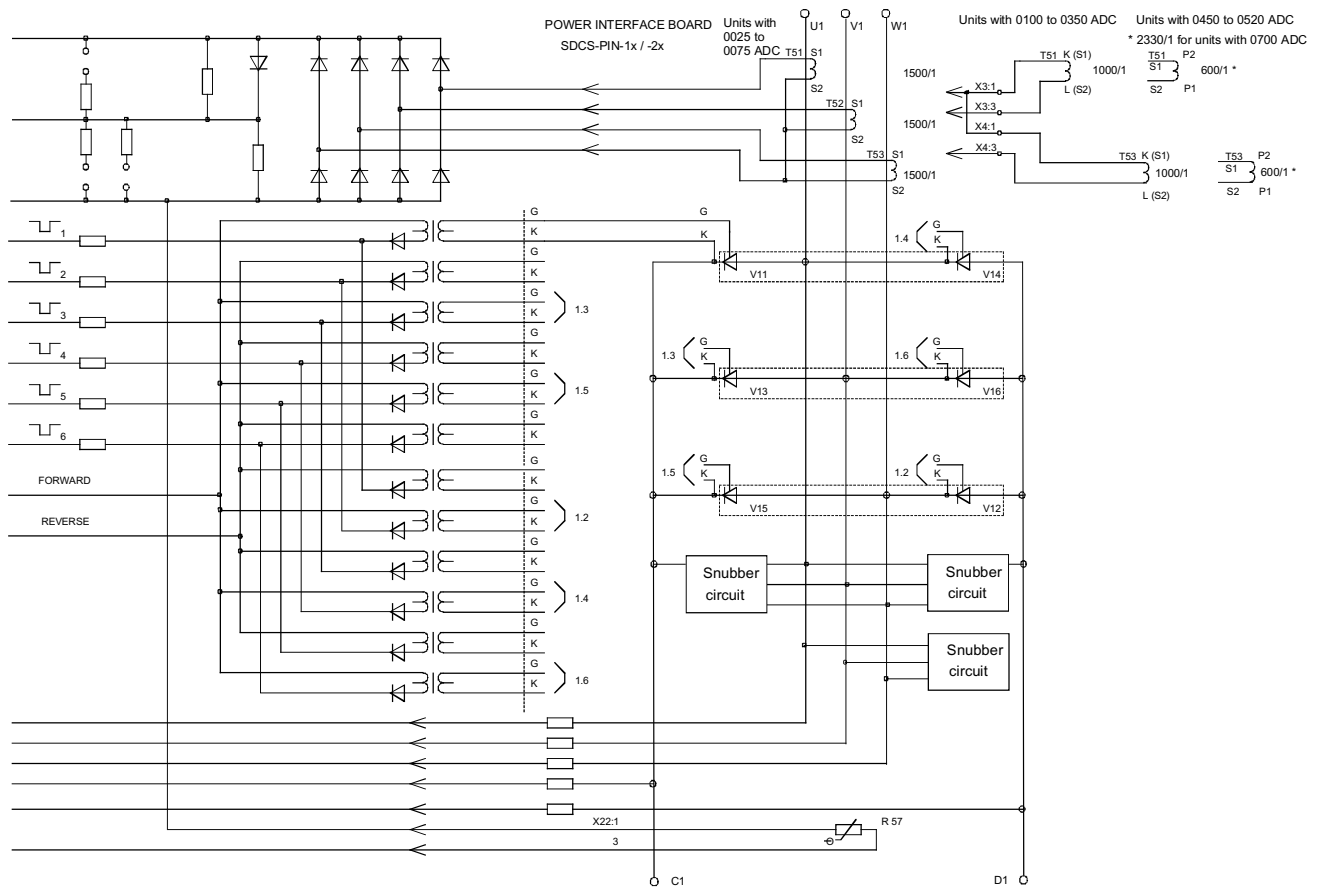

Figure 4-2 Location of thyristor modules in
 DCS 50x/60x-0025...0075 units
 DCS 502/602-0100...0700 units
 DCS 502/602-0680...1000 units

Note: This drawing is only for showing the location of the modules, the module size can be different!



Basic drawing / not all elements are shown

Figure 4-3 Basic drawing of DCS 501/601 units with SDCS-PIN-1x/-2x

Chapter 4 - Exchange of Thyristors for Sizes C1/C2/C2b

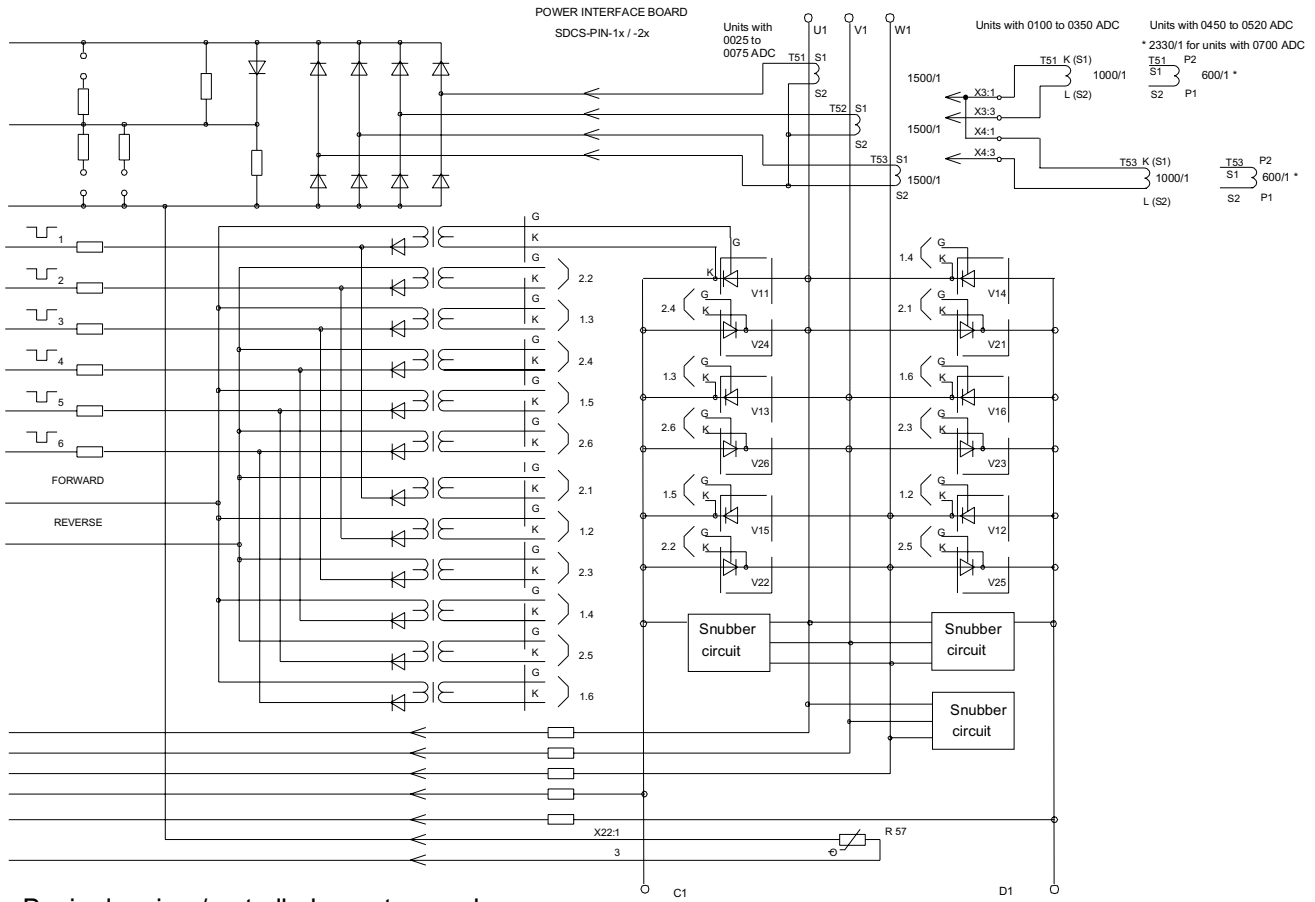

Figure 4-4 Basic drawing of DCS 502/602 units with SDCS-PIN-1x/-2x

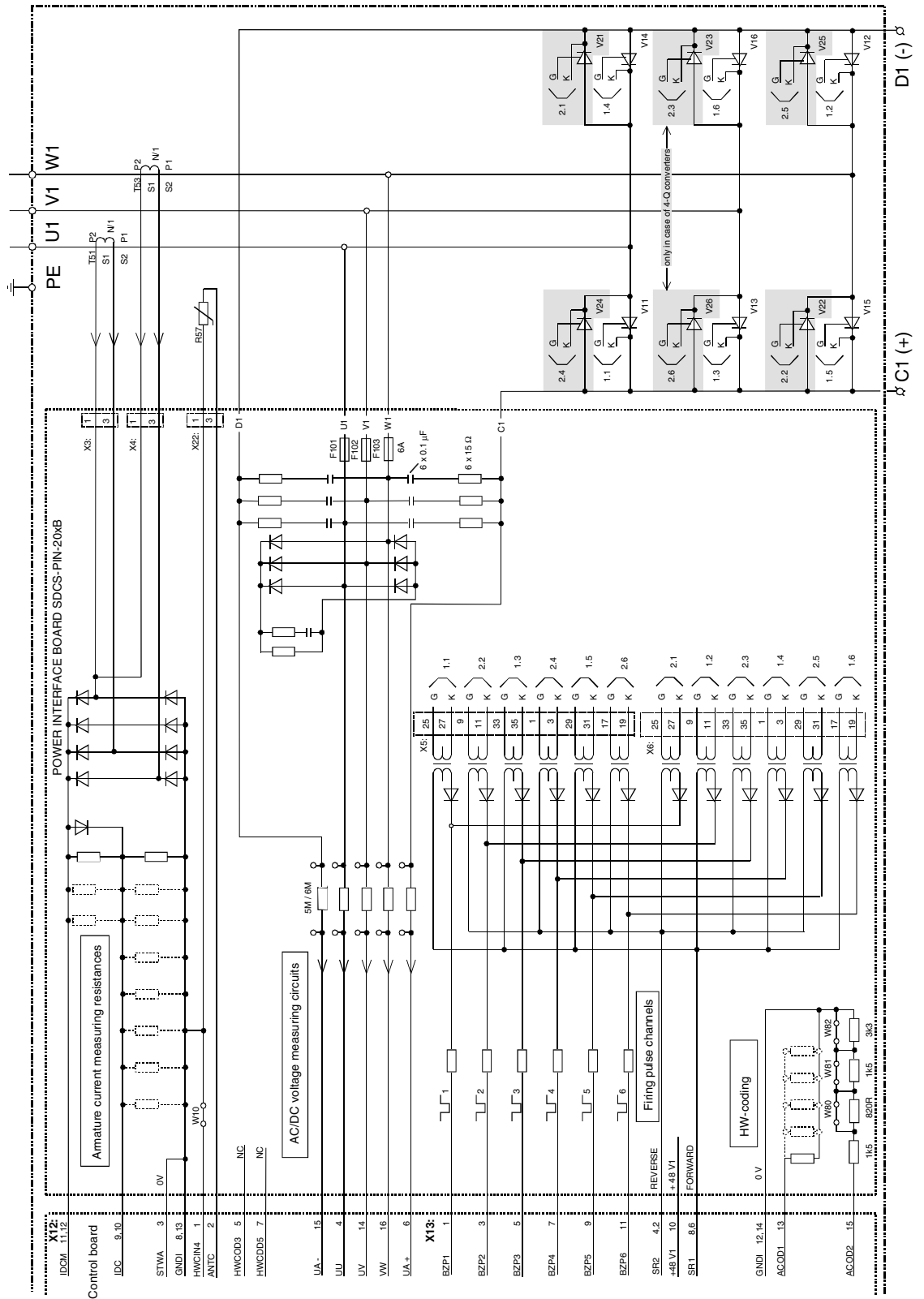
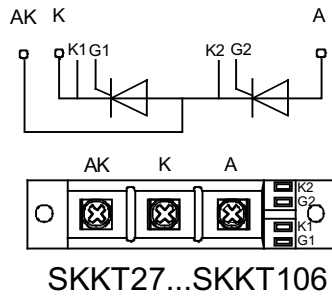

Figure 4-5 Typical armature circuit of DCS 50x/60x with SDCS-PIN-20xB

Module terminals

The next figures show a few examples and terminals of thyristor modules. The terminals of modules are also stamped or marked by a sticker.



Note: This drawing is **not** valid for the types SKKT....B...

Figure 4-6 Terminals of half-bridge thyristor modules

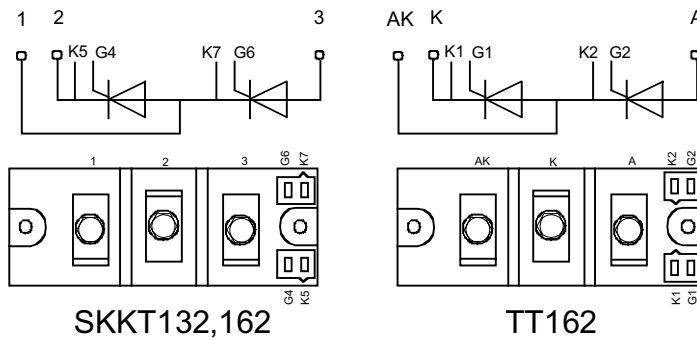

Figure 4-7 Terminals of half-bridge thyristor modules

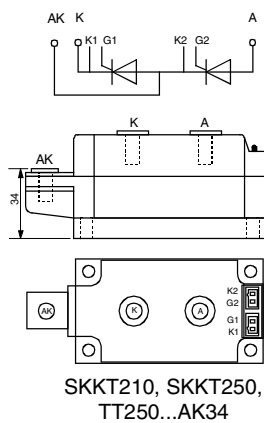

Figure 4-8 Terminals of half-bridge thyristor modules

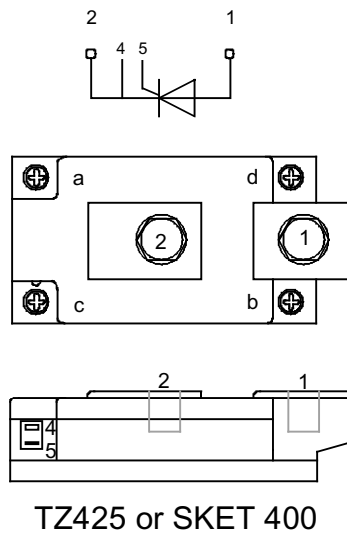

Figure 4-9 Terminals of single thyristor modules

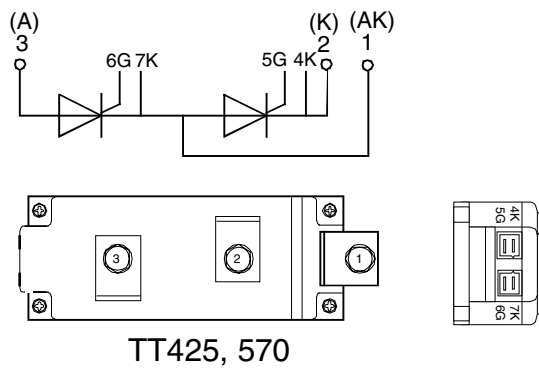

Figure 4-10 Terminals of half bridge thyristor modules

Chapter 5 - Exchange of Thyristors for Size A5

Installation of "Disc Type" thyristor in converters size A5 (900...2000 A)

All DCS 500 and DCS 600 converters sizes A5/C3/C4 are equipped with disk type thyristors. The structure of the "Disc type" semiconductor component is such that it requires a certain compression force to operate. The prevention of overheating of the component essentially depends on a well heat dissipation between the semiconductor and the conducted heat sink. It is thus important that all joints have good thermal and electrical conduction.

Required Tools

Special tools or material needed in addition to standard tools for the exchange of thyristor modules:

- Torque spanner for electrical connections:

13 Nm (M8)
25 Nm (M10)
50 Nm (M12)
- Screws are metric type; use appropriate nuts.
- 17 mm ring spanner for fuse and busbar connections.
- 17 mm ring spanner for press clamp.
- Tissue paper / solvent (e.g. ethanol).
- Thermal joint compound: type **BECHEM-RHUS SU 2** (grease)

Manufacturer:	Carl Bechem GmbH, 58089 Hagen
ABB Service:	GHSN 390 001 P 0001
- Disassembly tool

3ADT 621 023 P1

Note: For more detailed information about the wiring of the power part, see manual *Technical Data*.

Therefore strict observance of the build in instructions given below is of utmost importance. Make sure that the new component can replace the old one in accordance with the spare part list (see *Appendix A*).

Semiconductors and heat sinks are to be handled carefully to avoid scratches and other damage. Avoid touching the contact surfaces. Do not lift the semiconductor with the gate wire. Do not lift the semiconductor unit touching the current contact surfaces. Do not damage the welding flange or the contact surface.



Before you start work, disconnect the converter completely from the power supply then check the voltage free condition and make sure, everything is located in an electrically and mechanically safe condition!

- Find faulty thyristor**
1. Find the defective branches by performing an OHM test (both polarities) between U1, V1, W1 and C1, D1 (see figure 5-1)

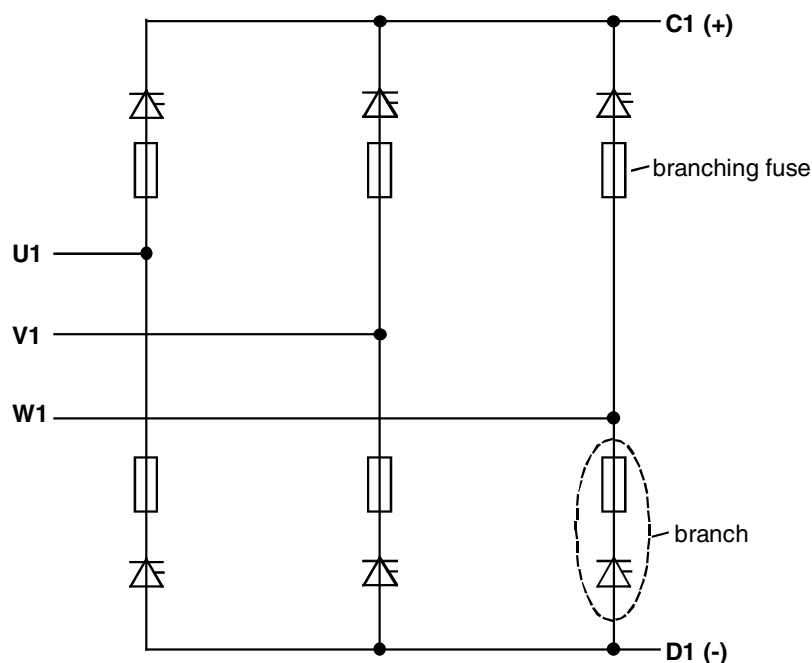

Figure 5-1 Basic B6-bridge with branching fuses

2. Disconnect the branch fuses of the defective branches.
3. Find the defective thyristors by performing an OHM test (both polarities) over their heat sinks.
4. In a 4-quadrant converter change both thyristors clamped between the same heatsinks at once.

Note: Because “Disc Type” semiconductors need a certain compression force to operate properly a measurement outside the clamped heat sinks might be wrong. To be sure change only one thyristor, clamp the heat sinks again and repeat step three.

Remove faulty thyristor

1. Remove the screws of the DC – busbars and branch fuses preventing the stack to be prized open.
Note: It depends on the location of the defective thyristor which DC – busbar and fuses have to be disconnected.
2. Write down the direction and location of the thyristors to be removed and mark their gate leads.
3. Remove the gate leads if possible.
4. Loosen the mounting clamp (see *figure 5-3*) at the top of the thyristor stack.

Attention: While loosen the mounting clamp the indicating spring must be pulled out a little, otherwise the spring will be damaged!

5. Attach the disassembly tool at the faulty thyristor and prize open the upper and lower heat sinks (see *figure 5-2*).
6. Remove the thyristors.

Attention: To centre the thyristors spring pins are used. The pins are inlaid into all lower heat sinks. Open the gap wide enough that the thyristor and the pins are not damaged while removing the thyristor!

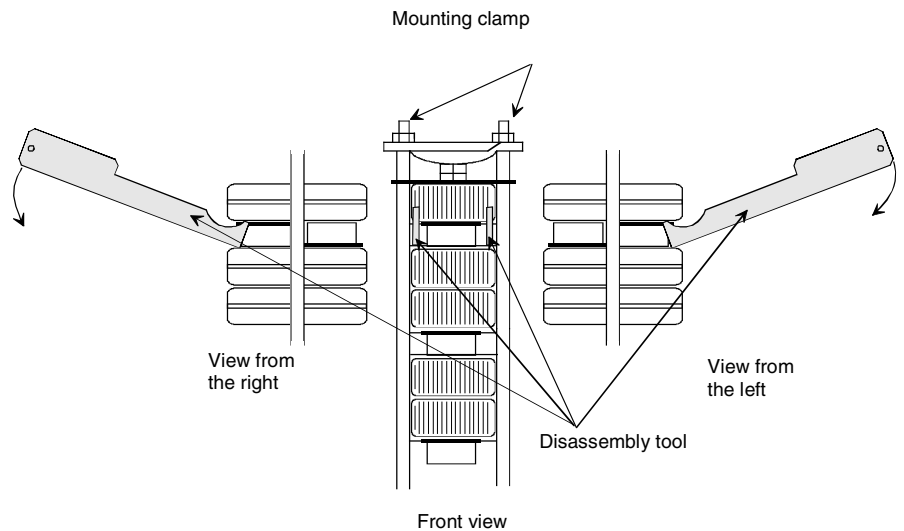

Figure 5-2 How to use the disassembly tool

Install new thyristor

1. Ensure that the new thyristor is of the correct type (see *Appendix A*). Keep the semiconductor and its surroundings clean. If necessary clean them with a piece of tissue paper moistened with solvent.
Note: Do not touch the polished surfaces of the thyristor.
2. Clean the polished surfaces of the semiconductor with a piece of tissue paper moistened with solvent. Dry all surfaces. Spread a **thin** layer of heat conducting paste on both sides of the thyristor, if necessary use a rubber spatula.
3. Connect the gate leads if possible.
4. Clean all parts with tissue paper moistened with solvent, which have had or will have contact with the thyristor or each other (lower / upper heat sink). Do not clean the surfaces of grease too thoroughly, because the aluminium surfaces will oxidise in a few seconds. Dry all surfaces.
5. Centre the thyristors by means of the spring pins.
Note: Be sure that the thyristor is installed in the right direction. Do not pinch or cut the gate leads or any other cable.
6. Turn the thyristor so that the gate leads point in the right direction.

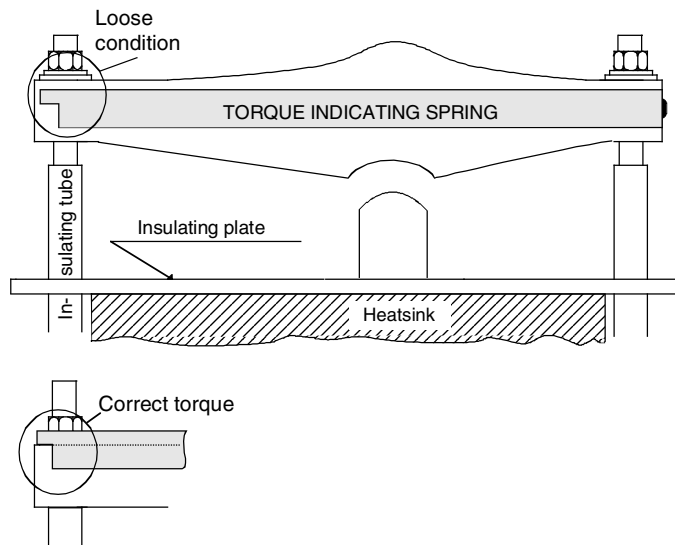

Figure 5-3 Aluminium spring with welded indicating spring

7. Tighten the nuts of the mounting clamp by hand so that the clamp is in parallel with the contact surface of the heat sinks.
Note: The indicating spring is a very sensitive instrument and must be handled with care.
8. Tighten each nut in turn, half a turn at a time with the help of a ring spanner until the indicating spring clicks into position “correct torque” (see *figure 5-3*). Do not tighten the screws any further.
Note: The correct torque is indicated by means of the welded indicating spring.
9. Perform an OHM test to make sure the thyristor is ok.
10. Reconnect the DC – busbars, branch fuses and all other dismantled parts.
11. Perform an OHM test between U1, V1, W1 and C1, D1 to make sure the power part is ok.

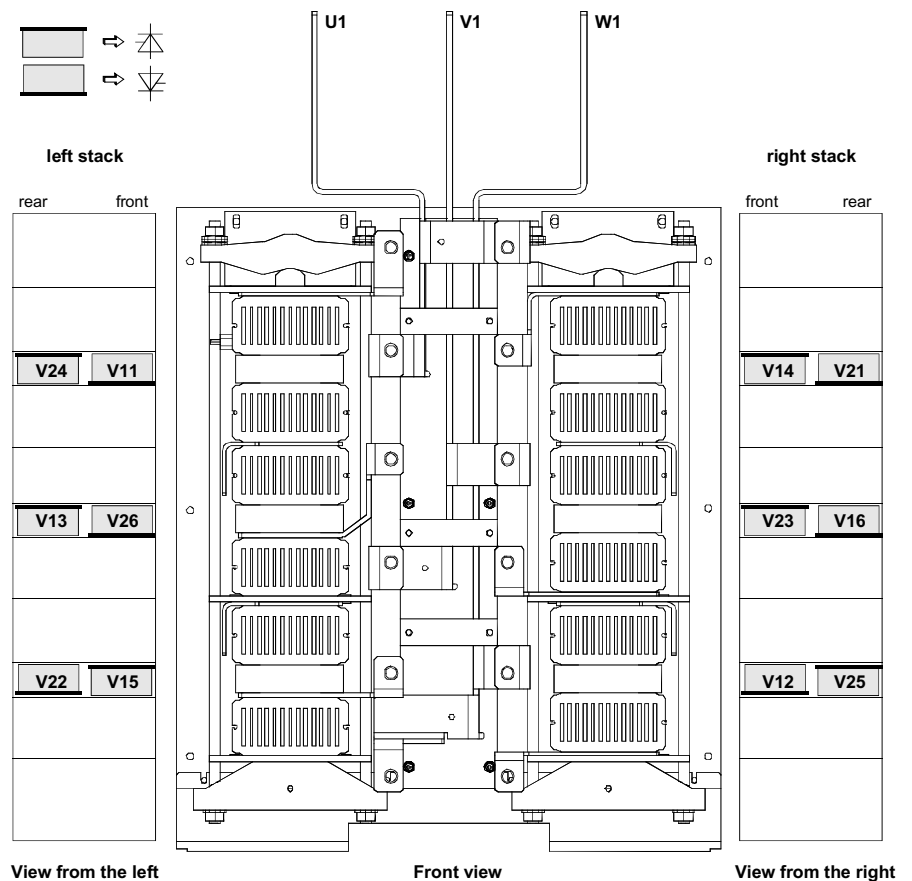

Figure 5-4 Location of thyristors in frame A5 (4-Q bridge)

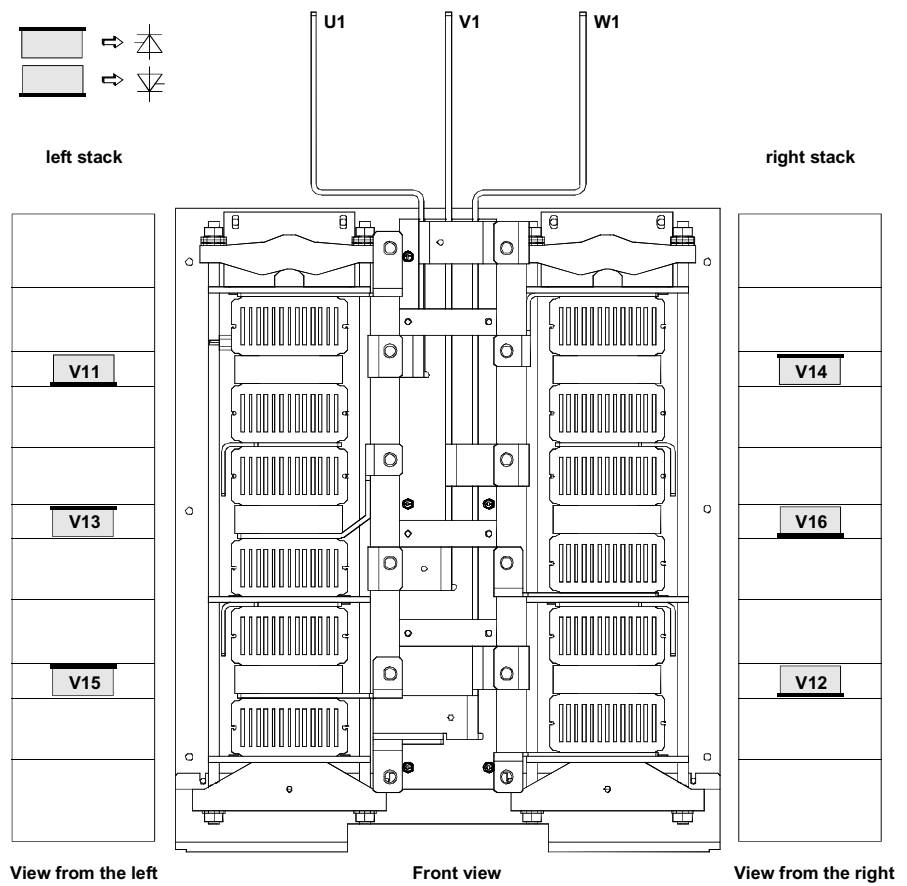

Figure 5-5 Location of thyristors in frame A5 (2-Q bridge)

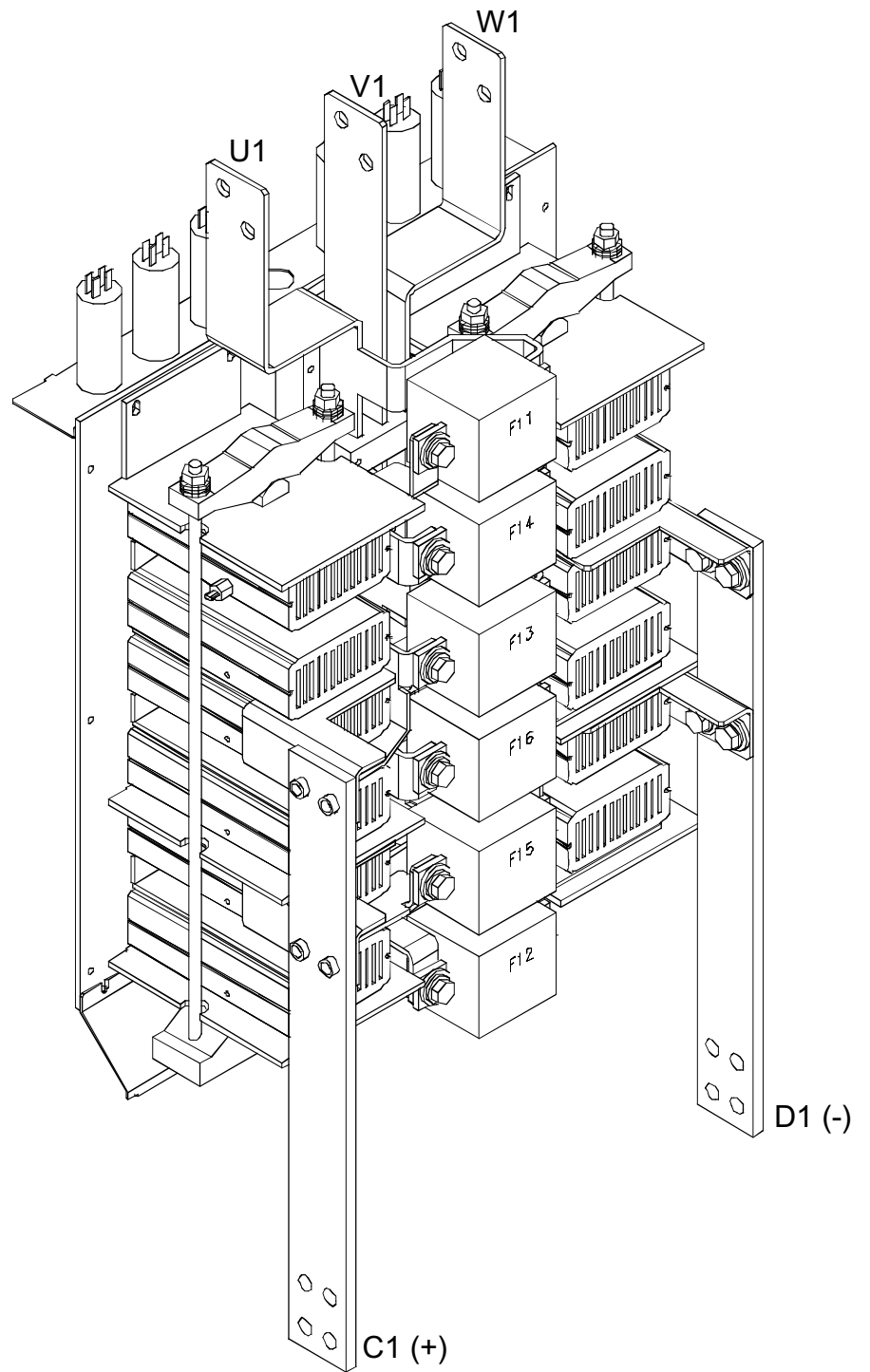

Figure 5-6 Location of branch fuses frame A5

Chapter 6 - Exchange of Thyristors for Size C3

Installation of "Disc Type" thyristor in converters size C3 (900...2000 A)

All DCS 500 and DCS 600 converters sizes A5/C3/C4 are equipped with disk type thyristors.

The structure of the "disc type" semiconductor component is such that it requires a certain compression force to operate. The prevention of overheating of the component essentially depends on a well heat dissipation between the semiconductor and the conducted heat sink. It is thus important that all joints have good thermal and electrical conduction.

Required Tools

Special tools or material needed in addition to standard tools for the exchange of thyristor modules:

- Torque spanner: mounting torques and forces for disc type thyristors see *Table 6-1*
electrical connections: 13 Nm (M8)
25 Nm (M10)
50 Nm (M12)
- Screws are metric type; use appropriate nuts.
- 13 mm nut for thyristor fixing with 20 mm max outer diameter.
- Tissue paper / solvent (e.g. ethanol).
- Molikote (MSO₂).
- Thermal joint compound: type **BECHEM-RHUS SU 2** (grease)

Manufacturer: Carl Bechem GmbH, 58089 Hagen
ABB Service: GHSN 390 001 P 0001

Note: For more detailed information about the wiring of the power part, see publication *Technical Data*.

Therefore strict observance of the build in instructions given below is of utmost importance. Different press clamps are used, depending on the size of the semiconductor. Make sure that the new component can replace the old one in accordance with the spare part list (see *Appendix A*).



Before you start work, disconnect the converter completely from the power supply then check the voltage free condition and make sure, everything is located in an electrically and mechanically safe condition!

Remove faulty thyristor

- Remove the plastic cover in front of the heat sinks; the screws are accessible, if the SDCS-PIN-x1 boards will be unfastened; there is no need to disconnect the electrical connections at the PIN-x1 boards.
- Remove the fuse, connected to that thyristor (pair) which needs to be exchanged.
- Disconnect the lead of a snubber capacitor connected to the heat sink; if the very right or left plastic cover is fixed at the heat sink, which needs to be removed remove the screw.
- If you have a 2 quadrant converter:
 - Loosen the screws, which keep the press clamp and the heat sink in position; remove the heat sink, mark the direction of the thyristor and the position of the gate leads, then remove the thyristor.
- If you have a 4-quadrant type converter:
 - Always start working at that thyristor which is part of the reverse bridge (V21, V22 a.s.o.) loosen the screws, which keep the press clamp and the heat sink in position; remove the heat sink, mark the direction of the thyristor and the position of the Gate leads, then remove the thyristor.

Find faulty thyristor

- Perform the OHM test with both polarities. Use the DC terminal of the antiparallel thyristors connected as one measuring point and the remaining heat sink as the other.
 - Case a) If this test indicates high resistance, the remaining thyristor is all right healthy and the one already removed should be marked and needs to be replaced.
 - Case b) If this test indicates low resistance, the remaining thyristor is faulty and needs to be replaced. Remove it in the way described above. The other thyristor is ok!
- In case a) of the OHM test described above mount a new thyristor at the position of the reverse bridge.
- In case b) of the OHM test described above a new thyristor for the forward bridge and afterwards the thyristor of the reverse bridge which was removed first have to be mounted.

Install new thyristor

- Ensure that the new thyristor is of the correct type (see *Appendix A*). Keep the semiconductor and its surroundings clean. If necessary clean them with a piece of tissue paper moistened with solvent. Make sure the insulator of the thyristor and the connections are fine.
Note: Do not touch the polished surfaces of the thyristor.
- Clean the polished surfaces of the semiconductor with a piece of tissue paper moistened with solvent. Dry all surfaces. Spread a **thin** layer of heat conducting paste on both sides of the thyristor, if necessary use a rubber spatula.
- Clean all parts with tissue paper moistened with solvent, which have had or will have contact with the thyristor or each other (bottom of upper heat sink, busbar on both sides and upper side of the DC and AC busbar). Do not clean the surfaces of grease too thoroughly, because the aluminium surfaces will oxidise in a few seconds. Dry all surfaces.
- Connect the gate leads if possible.
- Place the thyristor with the right direction into the guiding tool. Spread the heat conducting paste by turning the thyristor 90° left and right.
Note: Do not pinch or cut the gate leads or any other cable.
- Turn the thyristor so that the gate leads point in the right direction.

Fasten the clamp

- Spread a thin layer of Molikote (MSO_2) on the thread and under the lower side of the head of each of the screws, keeping the heat sink by means of the press clamp in place. Spread Molikote also on the side of the washers, which comes in contact with the screw. Spread a thin layer of heat conducting paste on the bottom of the heat sink with a rubber spatula. Place the busbar and the heat sink above the thyristor and fix them with the press clamp. Tighten the clamping screws by hand until the screw heads touch the bottom of the module.

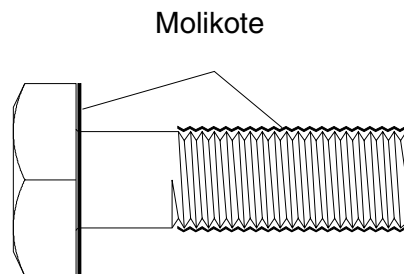

- Find the required torque from the table below. Tighten the screws alternatively 1/4 turn at a time until the correct torque is reached.

Converter type	Torque / Nm	Force / kN	Press clamp
400 V - 500 V			
DCS x0x-0900-4(5)	5,5 - 6	8 - 12	SLZF 89A
DCS x0x-1200-4(5)	5,5 - 6	8 - 12	SLZF 89A
DCS x0x-1500-4(5)	11,5 - 12	14,4 - 24	SLZF 89B
DCS x0x-2000-4(5)	11,5 - 12	14,4 - 24	SLZF 89B
600 V - 690 V			
DCS x0x-0900-6(7)	7,5 - 8	10 - 15	SLZF 89A
DCS x0x-1500-6(7)	11,5 - 12	14,4 - 24	SLZF 89B

Table 6-1 Mounting torques and forces for disc type thyristors

- In case of a 4-quadrant type converter:
 - Perform the OHM test with both polarities another time to make sure, the thyristor, which was used for the reverse bridge, is definitely healthy.
 - If this test indicates high resistance, the thyristor is healthy and can be used.
 - If this test indicates low resistance, the thyristor of the reverse bridge is faulty and needs to be replaced: remove it again mount a new one as described above.
- Install in the fuse(s).
- Connect the lead of the snubber capacitor, if it was removed before.
- Reconnect all parts, which were removed before:
 - plastic covers, etc.

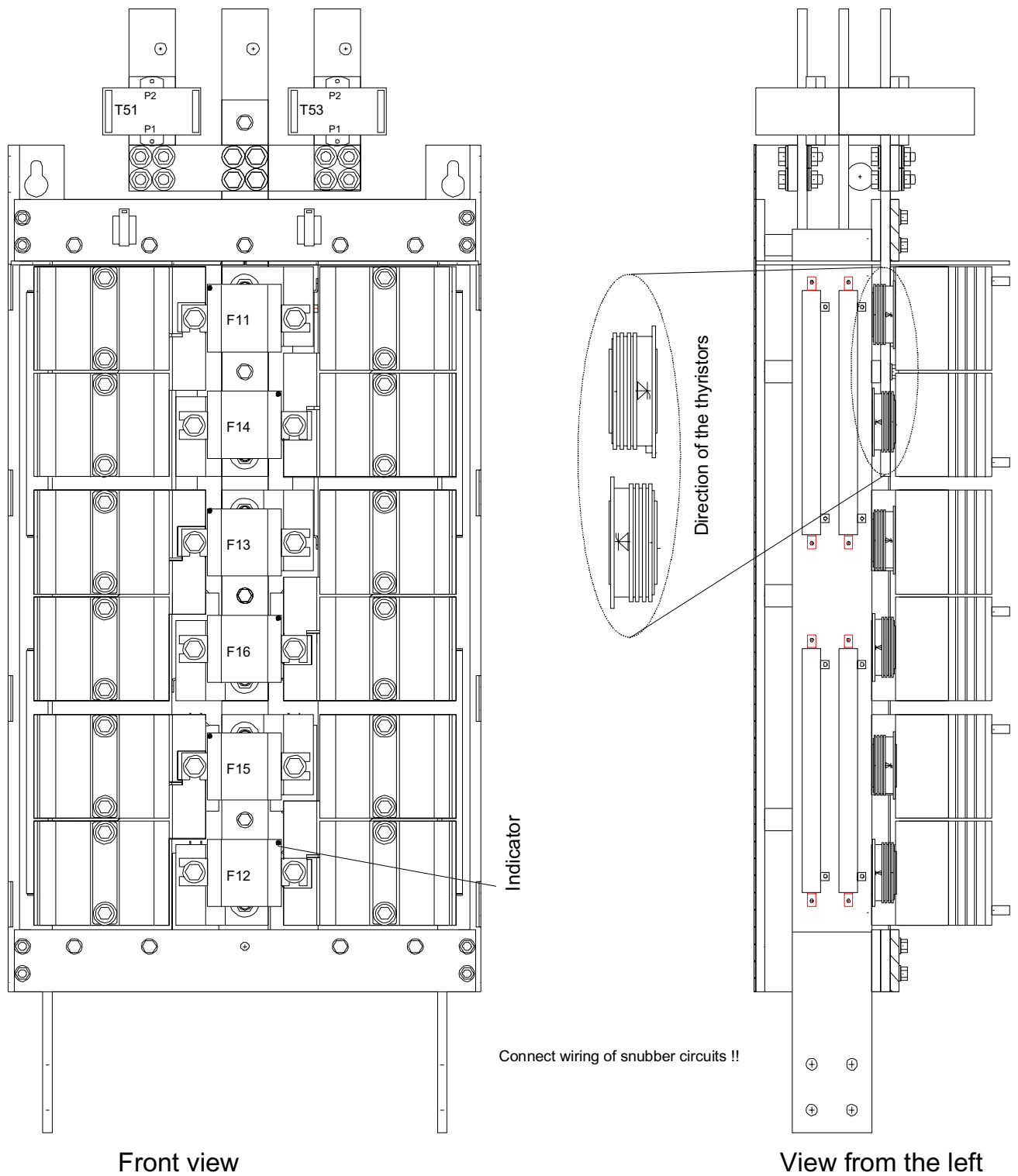

Figure 6-1 Location of thyristors in modules size C3

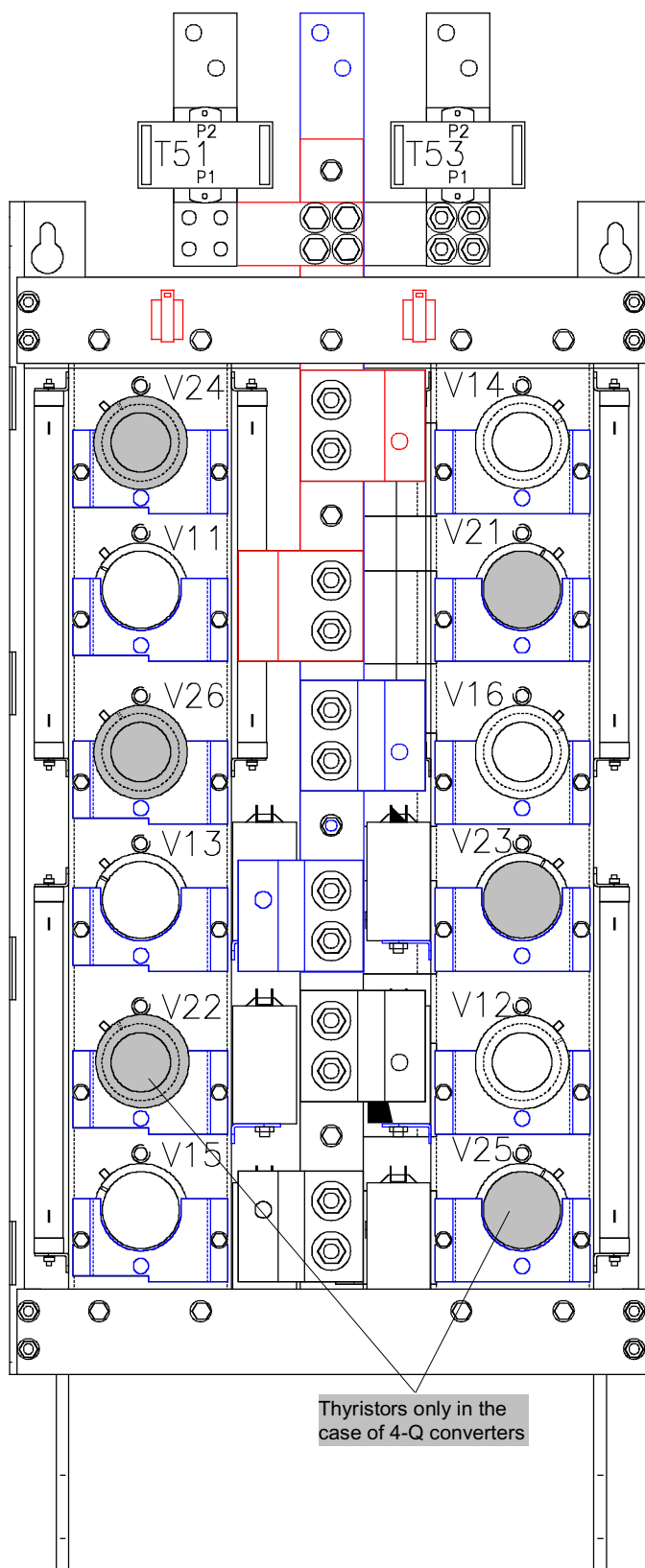

Figure 6-2 Location of thyristors in modules size C3
Note: Removed fuses, busbars and upper parts of heat sinks

Chapter 7 - Exchange of Thyristors for Size C4

Installation of "Disc Type" thyristor in converters size C4 (2050...5150 A)

All DCS 500 and DCS 600 converters sizes A5/C3/C4 are equipped with disk type thyristors.

The structure of the "Disc type" semiconductor component is such that it requires a certain compression force to operate. The prevention of overheating of the component essentially depends on a well heat dissipation between the semiconductor and the conducted heat sink. It is thus important that all joints have good thermal and electrical conduction.

Required Tools

Special tools or material needed in addition to standard tools for the exchange of thyristor modules:

- Torque spanner for electrical connections: 13 Nm (M8)
 25 Nm (M10)
 50 Nm (M12)
- Screws are metric type; use appropriate nuts.
- 17 mm ring spanner for fuse and busbar connections.
- 24 mm ring spanner for press clamp.
- Tissue paper / solvent (e.g. ethanol).
- Thermal joint compound: type **BECHEM-RHUS SU 2**
 (grease)
 Manufacturer: Carl Bechem GmbH, 58089 Hagen
 ABB Service: GHSN 390 001 P 0001
- Disassembly tool: DCF 1066721 P1

Note: For more detailed information about the wiring of the power part, see publication *Technical Data*.

Therefore strict observance of the build in instructions given below is of utmost importance. Make sure that the new component can replace the old one in accordance with the spare part list (see *Appendix A*).

Thyristors are always mounted in the same direction, independent of current, voltage, number of quadrants (2-Q or 4-Q) version or left or right side connection. Semiconductors and heat sinks are to be handled carefully to avoid scratches and other damage. Avoid touching the contact surfaces. Do not lift the semiconductor with the gate wire. Do not lift the semiconductor unit by touching the current contact surfaces. Do not damage the welding flange or the contact surface.

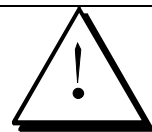

Before you start work, disconnect the converter completely from the power supply then check the voltage free condition and make sure, everything is located in an electrically and mechanically safe condition!

- Find faulty thyristor**
- Find the defective branch(es) by performing an OHM test (both polarities) between U1, V1, W1 and C1, D1 (see *Figure 5-1*).
 - Remove the screws of the left and right branch fuses. Remove the busbar, leading to the AC connection, too (not necessary at 2-quadrant converters, left version!).

 - If you have a 4-quadrant converter:
 - Remove the screws of the DC busbar either above or below the blown fuse.
Note: the connection is made with a screw socket, which may fall down, if the last screw is removed.
 - Put a small piece of isolator (paper, cardboard, plastic, etc.) between the DC busbar and the heat sink.
 - Perform the OHM test with both polarities between the DC busbar and the heat sink as the second measuring point.
 - Now perform the OHM test with both polarities between the isolated heat sink and the heat sink, which was connected to the fuse as the second measurement point.
 - Depending on the result, the thyristor located between the measuring terminals of the first test or the second one needs to be removed.

- Remove faulty thyristor**
- If the thyristor is partly covered by a fuse, loosen the screws and move the fuse some centimeters up or down; fix the fuse.
 - Remove the gate leads if possible.
 - Loosen the mounting clamp (see *Figure 7-2*) at the top of the thyristor stack.

Attention: While loosening the mounting clamp the indicating spring must be pulled out a little, otherwise the spring will be damaged!

- Attach the disassembly tool at the faulty thyristor and prise open the upper and lower heat sinks (see *Figure 7-1*). The copper bars need not be loosened .
- Remove the thyristor.

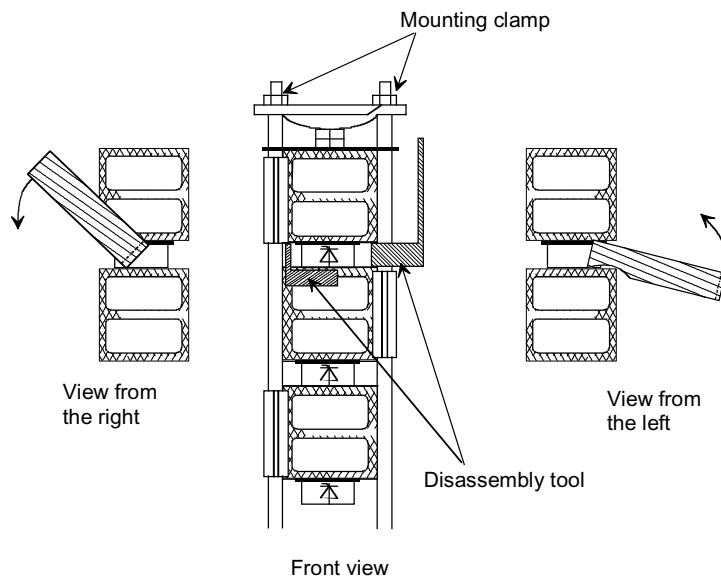

Figure 7-1 How to use the disassembly tool (at a left thyristor stack of a converter)

Install new thyristor

- Ensure that the new thyristor is of the correct type (see *Appendix A*). Keep the semiconductor and its surroundings clean. If necessary clean them with a piece of tissue paper moistened with solvent.
- Note:** Do not touch the polished surfaces of the thyristor.
- Clean the polished surfaces of the semiconductor with a piece of tissue paper moistened with solvent. Dry all surfaces. Spread a **thin** layer of heat conducting paste on both sides of the thyristor, if necessary use a rubber spatula.
- Connect the gate leads if possible.
- Clean all parts with tissue paper moistened with solvent, which have had or will have contact with the thyristor or each other (lower / upper heat sink). Do not clean the surfaces of grease too thoroughly, because the aluminium surfaces will oxidise in a few seconds. Dry all surfaces.
- Push the thyristor until it snaps into its mounting clamp.
- Note:** Be sure that the thyristor is installed in the right direction. Do not pinch or cut the gate leads or any other cable.
- Turn the thyristor so that the gate leads point in the right direction.

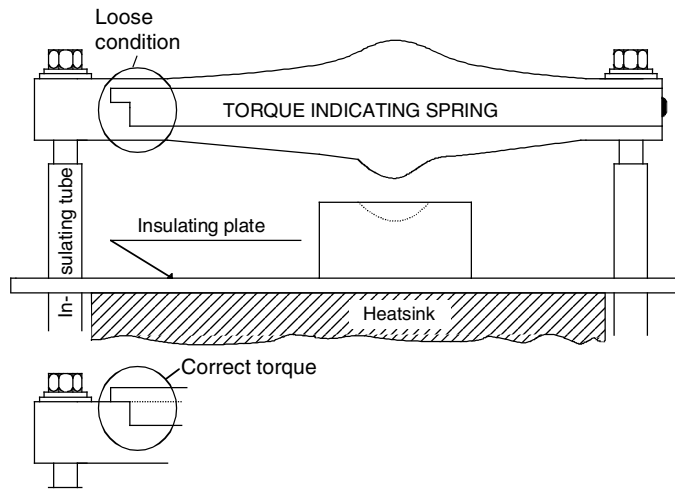

Figure 7-2 Aluminium spring with welded indicating spring

- Tighten the nuts of the mounting clamp by hand so that the clamp is in parallel with the contact surface of the heat sinks.
Note: The indicating spring is a very sensitive instrument and must be handled with care.
- Tighten each nut in turn, half a turn at a time with the help of a ring spanner until the indicating spring clicks into position “correct torque” (see Figure 7-2). Do not tighten the screws any further.
Note: The correct torque is indicated by means of the welded indicating spring.
- Perform an OHM test to make sure the thyristor is ok.
- Reconnect the DC / AC – busbars, branch fuses and all other dismantled parts.
- Perform an OHM test between U1, V1, W1 and C1, D1 to make sure the power part is ok.

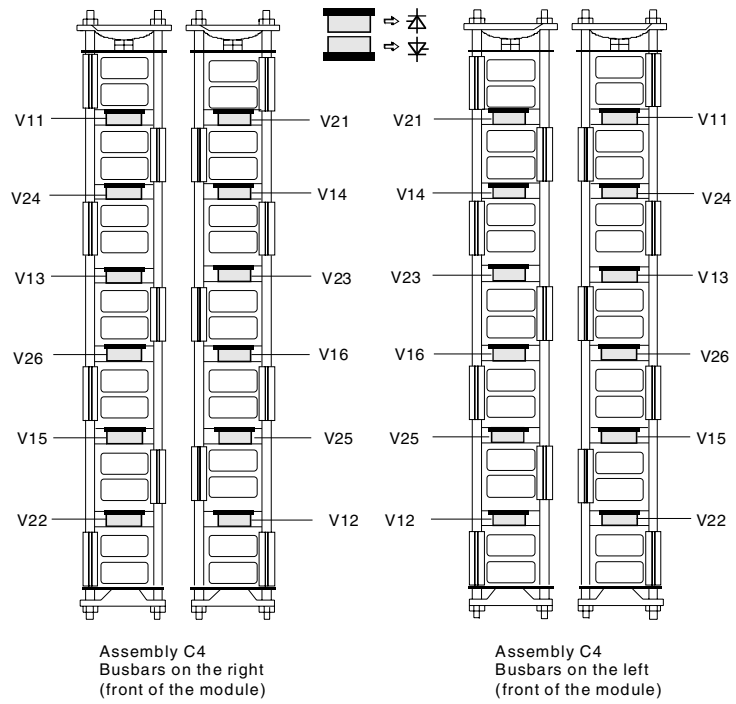

Figure 7-3 Location of thyristors in size C4 (4-Q bridge)

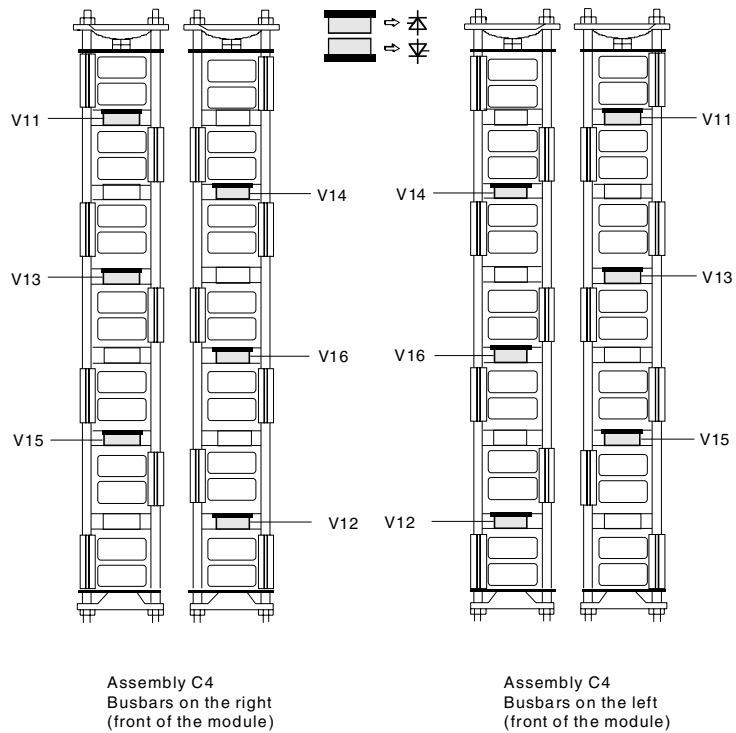

Figure 7-4 Location of thyristors in frame C4 (2-Q bridge)

Chapter 7 - Exchange of Thyristors for Size C4

Chapter 8 - Compatibility of SDCS-PIN-2 boards

Description of SDCS-PIN-20xB boards

- In general the SDCS-PIN-20xB board has the same features as its predecessors (SDCS-PIN-20xA/20x or SDCS-PIN-2x).
- It is used for all DCS converters Module sizes C1 ($\geq 100A$), C2 and C2b regardless of software version and function (armature or field supply).
- Converters equipped with the SDCS-PIN-20xB/20xA/20x boards can be identified by serial number. Every serial number is divided into two parts by a letter. With the SDCS-PIN-20xB/20xA/20x the serial number looks like 1234567B1234567. For the SDCS-PIN-2x an **A** is used.
- There are two types of SDCS-PIN-20xB boards:
 - SDCS-PIN-205B for converters with a incoming voltage of 400V/500V
 - SDCS-PIN-206B for converters with a incoming voltage of 600V
- The advantage of the SDCS-PIN-20xB/20xA/20x is the replacement of 6 other boards plus a small RC network. Thus the spare part handling becomes easier.

Hardware coding

On the SDCS-PIN-20xB resistors are used for hardware coding of the module, zero current detection and current scaling. In a new converter the resistors are already cut according to application. If the SDCS-PIN-20xB board is used as spare part all resistors are still uncut. The resistors have to be cut according to the table 'Settings of the SDCS-PIN-20xB board' as described in the manual *Technical Data*.

Snubber circuit

The incoming AC voltage is connected to the SDCS-PIN-20xB board via integrated fuses. The snubber circuit (RC network) is integrated as well and connected in parallel to the thyristors. This configuration leads to lower losses thus to a higher efficiency of the converter. Before larger converters had external RC networks. These are no longer needed.

Compatibility of SDCS-PIN-20x boards

The SDCS-PIN-20xB boards replaces SDCS-PIN-20xA and SDCS-PIN-20x boards, but not vice versa.

Note: SDCS-PIN-20xA replaces SDCS-PIN-20x, but not vice versa.

U _{AC}	400V/500V				600V		
	I _{DC}	100A-350A	405A-520A	700A	610A-1000A	100A-270A	405A/450A
Type		C1/C2	C2	C2	C2b	C1/C2	C2
SDCS-PIN-205B		✓	✓	✓	✓	-	-
SDCS-PIN-206B		-	-	-	-	✓	✓
SDCS-PIN-21		✓	-	-	-	-	-
SDCS-PIN-22		-	✓ ①	-	-	-	-
SDCS-PIN-23		-	-	-	-	✓	-
SDCS-PIN-24		-	-	-	-	-	✓ ①
SDCS-PIN-25		-	-	✓ ②	-	-	-
SDCS-PIN-205A/205		✓	✓	✓	-	-	-
SDCS-PIN-206A/206		-	-	-	-	✓	✓
✓: possible		-: not possible		① together with SDCS-PIR-21		② together with RC network	

Table 8-1 Compatibility of SDCS-PIN-2xx boards

Compatibility of SDCS-PIN-20x and SDCS-PIN-2x boards

Converters $100A \leq I_{DC} \leq 350A$ and U_{AC}: 400V/500V

- SDCS-PIN-21 or
- SDCS-PIN-205B/205A/205 can be used as spare parts.

Converters $405A \leq I_{DC} \leq 520A$ and U_{AC}: 400V/500V

- SDCS-PIN-22 together with SDCS-PIR-21 or
- SDCS-PIN-205B/205A/205 can be used as spare parts.

Converters I_{DC} = 700A and U_{AC}: 400V/500V (type C2)

- SDCS-PIN-25 together with RC network (possible only in converters with an **A** in their serial number) or
- SDCS-PIN-205B/205A/205 can be used as spare parts (possible in converters with an **A** or **B** in their serial number). In an **A** converter do **not** connect the RC network.

Note: In a **B** converter only SDCS-PIN205B/205A/205 boards are usable, because the RC network is missing.

Converters $610A \leq I_{DC} \leq 1000A$ and U_{AC}: 400V/500V (type C2b) only

- SDCS-PIN-205B can be used as spare part.

Converters $100A \leq I_{DC} \leq 270A$ and U_{AC}: 600V

- SDCS-PIN-23
- SDCS-PIN-206B/206A/206 can be used as spare parts.

Converters I_{DC} = 405A/450A and U_{AC}: 600V

- SDCS-PIN-24 together with SDCS-PIR-21 or
- SDCS-PIN-206B/206A/206 can be used as spare parts.

Note: In addition to above mentioned limitations make sure that the resistors are cut properly according to the table 'Settings of the SDCS-PIN-20xB board' as described in the manual *Technical Data*. Especially when a board is reused!

Change SDCS-PIN-2x boards

The converter is equipped with a SDCD-PIN-21/22/23/24 board:

- Make sure, electrical and mechanical safety is obtained!
- Mark the cables connected to U1, V1, W1 and C1, D1. Mark the plugs connected to X22, X3 and X4.
- Disconnect all cables and plugs.
- Remove the SDCS-PIN-2x board.

Note: If the converter is equipped with a SDCS-PIR-21 there is no need to remove this board separately, because it is mounted on the SDCS-PIN-2x board.

- Make sure that the resistors on the new board are cut properly according to the table 'Settings of the SDCS-PIN-20xB board' as described in the manual *Technical Data*.

- Install the new SDCS-PIN-20xB board.

Note: SDCS-PIN-205B replaces SDCS-PIN21/23 and SDCS-PIN-206B replaces SDCS-PIN-22/24.

- Reconnect all cables and plugs.

The converter is equipped with a SDCD-PIN-25 board:

- Make sure, electrical and mechanical safety is obtained!
- Mark the cables connected to U1, V1, W1 and C1, D1. Mark the plugs connected to X22, X3 and X4.
- Disconnect all cables and plugs.
- Remove the SDCS-PIN-25 board.

Note: The additional RC network is not needed anymore. Due to safety reasons remove the cables marked U1 – C14, V1 – C16, W1 – C12, C1 – R15 and D1 – R12.

- Make sure that the resistors on the new board are cut properly according to the table 'Settings of the SDCS-PIN-205B board' as described in the manual *Technical Data*.

- Install the new SDCS-PIN-205B board.

Note: SDCS-PIN-205B replaces SDCS-PIN25.

- Reconnect all cables and plugs.

Chapter 8 - Compatibility of SDCS-PIN-2 boards

Chapter 9 - Preventive Maintenance



WARNING! Before performing any maintenance the chapter 'Safety Instructions' at the beginning of this manual and within the corresponding *Operating Instructions* must be followed. Negligence of these instructions can cause injury or death.

Recommended regular maintenance

The DCS requires very little maintenance if installed in an appropriate environment.

An annual check for dust accumulation and corrosion inside the module / cabinet is recommended.

Air Filters

When air filters are used, the filters should be checked regularly depending on environmental conditions. Clogged up filters prevent the proper cooling of the drive.

Wash dirty filters with water (60°C) and detergent.

Cooling air pressure switch in converter modules type C4

The cooling air pressure switch must be checked regularly.

The following actions have to take place:

- Make sure electrical safety is performed.
- Open the module's door and hold it in position to prevent any movement.
- Repeat it with the cabinet's door.
- Switch on the drive and try to turn the motor.
- The air pressure switch is ok when the converter is switched off by error "F50 NO C FAN"; crosscheck this result with the module's door closed.

Fan

The lifetime of the cooling fan is about 20.000 to 40.000 hours depending on the converter type. The actual lifetime depends on the usage of the DCS and the ambient temperature.

Fan failure can be predicted by means of increasing noise from its bearings and a gradual rise of the heatsink temperature. If the DCS operates in a critical part of the process it is recommended to replace the fan once the above mentioned symptoms appear.

Heatsink

The DCS will run into overtemperature faults if the heatsinks are not clean. In an appropriate environment the heatsinks should be checked and cleaned annually.

Use compressed air to remove the dust from the heatsinks (the air flow must be from bottom to top). Fan rotation caused by the compressed air must be stopped in order to prevent damage. Additionally use a vacuum cleaner to clean the dust from the air inlet and outlet.

Internal high current connections in converters type C4

The thyristors together with the heatsinks are stacked. Every single thyristor is connected to the DC+ and DC- busbars via flexible copper busbars. These busbars consist of 10 layers of preshaped sheet copper. This construction is able to compensate for small changes in length caused by temperature rise when current is flowing. The screw fixings between heatsink and flexible copper busbar have to withstand different types of mechanical stress. Therefore each fixing needs to be checked for correct torque. This check should be done regularly, e.g. annually or together with all the other work to be done for preventive maintenance.

Actions:

- Make sure all supply voltages are switched off, most important the supply for the power part (armature), for the electronic power part (SDCS-POW-1), for the converter fan and for other auxiliaries!
- Open the cabinet's and module's door; if needed secure them.
- Set a latching torque spanner to 25 Nm (18 lb-ft); a 17 mm nut is needed too.
- Check the torque of the screws marked within *Figure 9-1* at the end of this chapter:
 - Apply the torque spanner to the screw and turn right until the right torque is indicated.
 - Don't loosen the screws by a left hand turn!
 - Put on a new marking, if appropriate.

Relays and electrical connections

Relays should be checked for proper function and all connections should be inspected and checked for tightness. Any signs of corrosion, especially at ground components, must be removed.

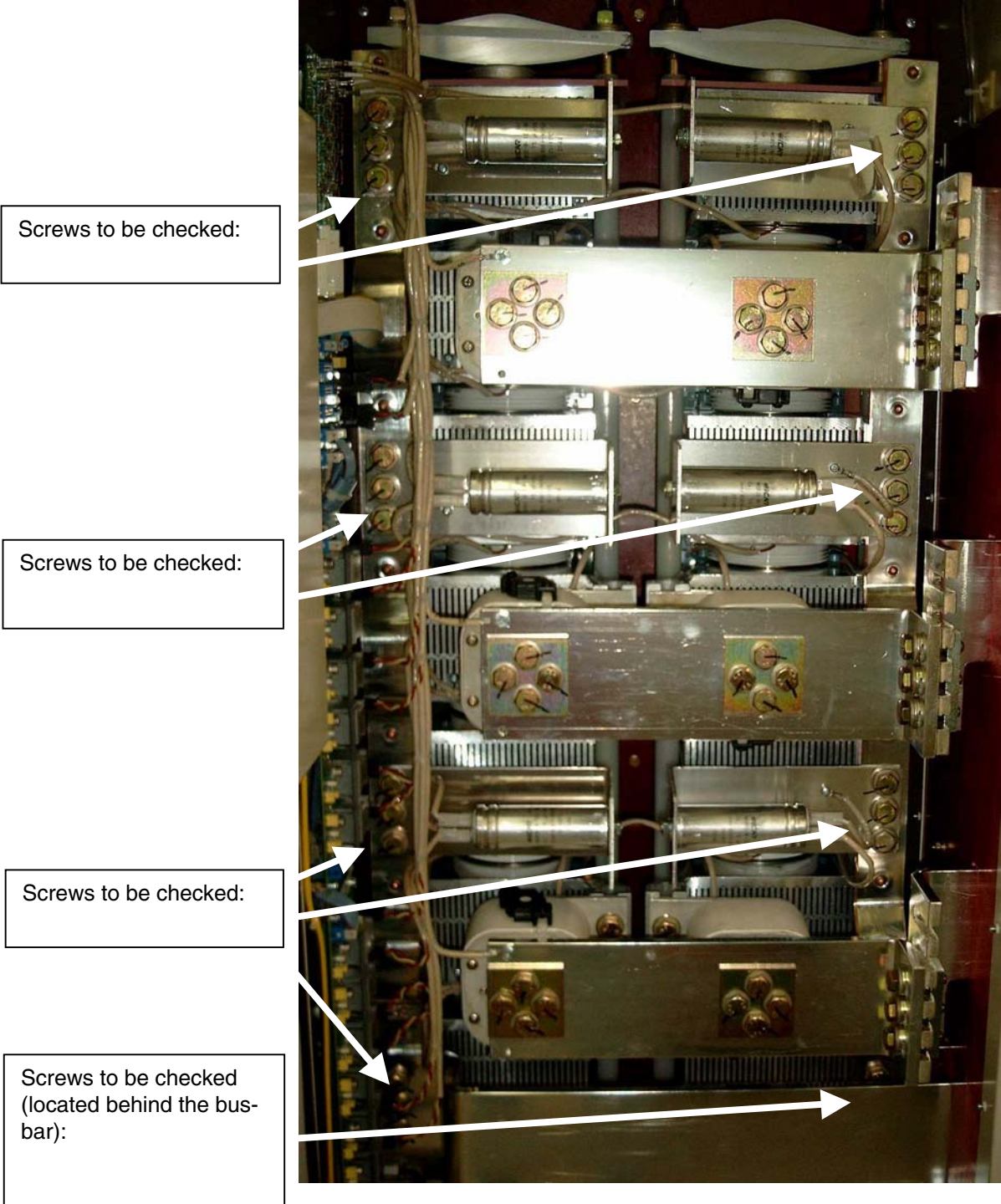

Figure 9-1: Power part of a converter module type C4

Appendix A - Spare Parts List

Item 2.10 to Item 3.60 Common Electronic Parts

2.10 COMMON PARTS FOR CONV. DCS500B/DCF500Bxxxx-xx-21..(CON-2)					
DESCRIPTION	QTY		CODE	TYPE/DATA	NOTES
Control board DCS500 B	1		3ADT220072R4	SDCS-CON - 2	with actual software21.xxx
Power supply board	1		3ADT220090R3	SDCS-POW-1 COAT	

2.20 COMMON PARTS FOR CONV. DCS600 / DCF600xxxx-xx-15.MultiDrive; 18.Crane SW					
DESCRIPTION	QTY		CODE	TYPE/DATA	NOTES
Control board +AMC-DC Board	1*		3ADT220072R5	SDCS-CON-2+AMC-DC	w.act. SW.15.xxx+AMC-DC-Board.
Control board +AMC-C-Clas1.	1*		3ADT220072R7	SDCS-CON-2+AMC-C	w.act.SW.15.xxx+AMC-C-Board.
Control b.+AMC-DC Crane	1*		3ADT220072R22	CON-2-18+AMC DC	Crane SW18+AMC-DC; incl.Fee
Control b.+AMC-C-Clas1/Crane	1*		3ADT220072R20	CON-2-18+AMC-C	Crane SW18+AMC-C;incl.Fee
Power supply board	1		3ADT220090R3	SDCS-POW-1 COAT	

*) Select only one Board

2.30 Interface Boards; Panels for DCS500B/DCS600 Modules / Cabinets					
DESCRIPTION	QTY		CODE	TYPE/DATA	NOTES
)DI/DO connection board	1		3BSE005176R1	SDCS-IOB-21	24V DC-48V DC
)DI/DO connection board	1		3BSE005177R1	SDCS-IOB-22	115V AC
)DI/DO connection board	1		3BSE005178R1	SDCS-IOB-23	230V AC
AI/AO connection board	1		3BSE004086R1	SDCS-IOB-3	
Communication Board/DCS500B	1		3ADT220059R1	SCDS-COM-5	separate; only for DCS500B
AMC-Communic. Board DCS600	1		3ADT309900R1	AMC-DC Board	without Software f. DCS600
AMC-Communic. Board DCS600	1		3BSE017192R1	AMC-DC_Clas1-Board	without Software f. DCS600
Control Panel	1		3ADT220071R5	CDP312 Rev.F	For DCS500B & DCS600
I/O Extension Board	1		3BSE005851R1	SDCS-IOE-1	
Adapt. Board /Analog Tacho	1		3ADT300600R1	PS 5311- SET	

*) Select only one Board

DCR-Kit contains: 2Q 4Q

2.40 PARTS FOR DCR REBUILD KITS, 12 PULSE AND PARALLELING DCS CONV.					
DESCRIPTION	2 Q	4 Q	CODE	TYPE/DATA	
Cooling fan	1	1	DCA0017670P1	CN52B2	for DCR500B/600 Type
Pulse Interface Board	1	1	DCF1154914R1	SDCS-REB-1	DCR
Pulse Amplifier Board	1	1	DCF1192115R1	SDCS-REB-2	DCR
Pulse Distribution Board	1	1	3ADT309300R1	SDCS-REB-3	DCR
Power Supply for REB-2	2	2	DCE8920037P1	NPSM-01	230V///24V DC// 2A DCR
SDCS- PIN- 41A and PIN-51 see item 19.00 - 38.00 or below					
Pulstransformer Board	1	2	3BSE004939R1	SDCS-PIN-41 A	
Power interface board	1	1	3BSE004940R1	SDCS-PIN-51	for 400V up to 1000V AC
Current Measurement Aid	1	1	3ADT220090R22	SDCS-CMA-2-Coat	12 Pulse and Paralleling Converter
Paralleling Interface Board 1	1	1	3ADT311200R1	SDCS-PAR-1	Paralleling Master Conv.
Paralleling Interface Board 2	1	1	3ADT311300R1	SDCS-PAR-2	Paralleling Slave Conv.

Appendix A- Spare Parts List

2.50 2-PHASE FIELD EXCITERS					
DESCRIPTION	QTY		CODE	TYPE/DATA	NOTES
Integrated uncontr. 6 A; FEX-1	1		DCA0012317R1	SDCS-FEX-1	Sep. compl. Unit; incl. Diode M.
Integrated single 16 A; FEX-2	1		DCA0012325R1	SDCS-FEX-2 A	Sep. compl. Unit; incl. Thyristor M.
Control Board DCF503A0050	1		3ADT312400R2	SDCS-FEX-32A	Control Board f. DCF503A0050
Thyristor/Diode Module 1Q 50A	2		DCA0003270P1	SKKH 57/16 E	for DCF503-0050
Control Board DCF504A0050	1		3ADT312400R1	SDCS-FEX-31A	Control Board f.DCF504A0050
Thyristor modules 4Q 50A	2		DCA0011132P1	SKKT42/16E	for DCF504-0050
Ext. DCF503A0050; 1Q 50 A	1		3ADT209019R1	DCF503A0050	Complete unit DCF503A0050
Ext. DCF504A0050; 4Q 50 A	1		3ADT209019R2	DCF504A0050	Complete unit DCF504A0050

3.10 Coated Boards for DCS500B see item 2.10					
DESCRIPTION	QTY		CODE	TYPE/DATA	NOTES
Control board DCS500 B	1		3ADT220072R12	SDCS-CON - 2-21-coat	with actual software21.xxx
Power supply board	1		3ADT220090R3	SDCS-POW-1 COAT	Repl. for DCA0012279R0001

3.20 Coated Boards for DCS600 / DCF600 see item 2.20					
Control board +AMC-DC Board	1*		3ADT220072R9	CON-2+AMC-DC-coat	w.act. SW.15.xxx+AMC-DC-Board.
Control board +AMC-C-Clas1.	1*		3ADT220072R11	CON-2+AMC-C-coat	w.act.SW.15.xxx+AMC-C-Board.
Power supply board	1		3ADT220090R3	SDCS-POW-1 COAT	Repl. for DCA0012279R0001

3.30 Coated Interface Boards; Panels for DCS500B / DCS600 Modules / Cabinets					
)DI/DO connection board	1		3ADT220090R14	SDCS-IOB-21-coat	24V DC-48V DC
)DI/DO connection board	1		3ADT220090R13	SDCS-IOB-22-coat	115V AC
)DI/DO connection board	1		3ADT220090R23	SDCS-IOB-23-coat	230V AC
AI/AO connection board	1		3ADT220090R20	SDCS-IOB-3-coat	
Communication Board	1		3ADT220090R26	SCDS-COM-5-coat	separate
I/O Extension Board	1		3ADT220090R25	SDCS-IOE-1-coat	
Adapt. Board /Analog Tacho	1		3ADT220090R29	PS 5311- coat	

3.40 Coated Boards for DCR Rebuild Kits and 12 PULSE-Systems See item 2.30					
Pulse Interface Board	1	1	3ADT220090R9	SDCS-REB-1-coat	Coated Board for DCR
Pulse Amplifier Board	1	1	3ADT220090R34	SDCS-REB-2-coat	Coated Board for DCR
Pulstransformer Board	1	2	3ADT220090R5	SDCS-PIN-41 A-coat	
Power interface board	1	1	3ADT220090R6	SDCS-PIN-51-coat	for 400V up to 1000V AC
Current Measurement Aid	1	1	3ADT220090R22	SDCS-CMA-2-coat	12 Pulse and Paralleling Converter

3.50 Coated Boards for 2-PHASE FIELD EXCITERS see item 2.50					
Integrated single 16 A; FEX-2	1		3ADT220090R19	SDCS-FEX-2 A-coat	Sep. compl. Unit; coated Vers.
Control Board DCF503A0050	1		3ADT220090R37	SDCS-FEX-32A-coat	Coat. Contr. Board DCF503A..
Control Board DCF504A0050	1		3ADT220090R36	SDCS-FEX-31A-coat	Coat. Contr. Board DCF504A..
Ext. DCF503A-0050; 1Q 50 A	1		3ADT209019R0101	DCF503A0050-Coat	Complete unit DCF503A0050
Ext. DCF504A0050; 4Q 50 A	1		3ADT209019R0102	DCF504A0050-Coat	Complete unit DCF504A0050

3.60 Coated Boards for 25A - 5150A Modules					
Power interface board	1	1	3ADT220090R27	SDCS-PIN-11-coat	25A; 50A and 75A Mod.
Power interface board	1	1	3ADT220090R35	SDCS-PIN 205B-Coat	100A - 1000A/400/500V Mod.
Power interface board	1	1	3ADT220090R38	SDCS-PIN 206B-Coat	110A,270A and 450A/600V M.
Power interface board	1	1	3ADT220090R6	SDCS-PIN-51-coat	for 400V up to 1000V AC
Puls transformer board	1	2	3ADT220090R5	SDCS-PIN-41 A-coat	900A - 5150A

*) Select only one Board

Appendix A- Spare Parts List

Item 4.00 to 10.00 Modules DCS500B / DCS600 Size C1 25A----140A

4.00 Common Parts for C1, C2, C2b and C3 Modules					
DESCRIPTION	2 Q	4 Q	CODE	TYPE/DATA	NOTES
Temperature Sensor (R57)	1	1	DCA0012139P1	KTY 10-6 M4	(C1-C3 / 550mm cable)

Fuse F101; F102 and F103 on PIN205B and PIN206B see Modules from 100A to 1000A; item 8.00 - 18.00

Module contains:	2Q	4Q
------------------	----	----

4.10 25 A (400V-500V) CONVERTER					
DESCRIPTION	2 Q	4 Q	CODE	TYPE/DATA	NOTES
Thyristor modules	3	6	DCA0008018P1	SKKT27/16E *	
Power interface board	1	1	3ADT306100R1	SDCS-PIN-11	DCF501,502B, DCF 601, 602 (1)
Semiconductor fuses	3	3	DCZ9838767P1	170M1564	
Cooling fan	1	1	DCA0017670P1	CN52B2	

(1) If used as a spare part for DCF... the resistors R113/R116/R119 must be removed. For further information see "Technical Data"

* DCS500/DCS600 Thyr. Modules SKKT 27 / 16E are not identical to Thyr. Modules SKKT 27 B/16E used for DCS400 Converter Modules

Module contains:	2Q	4Q
------------------	----	----

5.00 50 A (400V-500V) CONVERTER					
DESCRIPTION	2 Q	4 Q	CODE	TYPE/DATA	NOTES
Thyristor modules	3	6	DCA0011132P1	SKKT42/16E *	
Power interface board	1	1	3ADT306100R1	SDCS-PIN-11	DCF501,502B, DCF 601, 602 (1)
Semiconductor fuses	3	3	DCZ9838791P1	170M1566	
Cooling fan	1	1	DCA0017670P1	CN52B2	

(1) If used as a spare part for DCF... the resistors R113/R116/R119 must be removed. For further information see "Technical Data"

* DCS500/DCS600 Thyr. Modules SKKT 42 / 16E are not identical to Thyr. Modules SKKT 42 B/16E used for DCS400 Converter Modules

Module contains:	2Q	4Q
------------------	----	----

6.00 50 A (600V) CONVERTER					
DESCRIPTION	2 Q	4 Q	CODE	TYPE/DATA	NOTES
Thyristor modules	3	6	DCA0011906P1	SKKT57/20E *	
Power interface board	1	1	3BSE005716R1	SDCS-PIN-12	
Semiconductor fuses	3	3	DCZ9838791P1	170M1566	changed Oct.2001
Cooling fan	1	1	DCA0017670P1	CN52B2	

* DCS500/DCS600 Thyr. Modules SKKT 57 / 16E are not identical to Thyr. Modules SKKT 57 B/16E used for DCS400 Converter Modules

Module contains:	2Q	4Q
------------------	----	----

7.00 75 A (400V-500V) CONVERTER					
DESCRIPTION	2 Q	4 Q	CODE	TYPE/DATA	NOTES
Thyristor modules	3	6	DCA0011914P1	SKKT57/16E *	
Power interface board	1	1	3ADT306100R1	SDCS-PIN-11	DCF501,502B, DCF 601, 602 (1)
Semiconductor fuses	3	3	DCA0012686P1	170M1568	
Cooling fan	1	1	DCA0017670P1	CN52B2	

(1) If used as a spare part for DCF... the resistors R113/R116/R119 must be removed. For further information see "Technical Data"

* DCS500/DCS600 Thyr. Modules SKKT 57 / 16E are not identical to Thyr. Modules SKKT 57 B/16E used for DCS400 Converter Modules

Module contains: 2Q 4Q

8.00 100 A (400V-500V) CONVERTER					
DESCRIPTION	2 Q	4 Q	CODE	TYPE/DATA	NOTES
Thyristor modules	3	6	DCA0011931P1	SKKT 106/16E *	
Power interface board	1	1	3ADT312500R1	SDCS-PIN 205B	Repl. SDCS PIN-21 and PIN205
Fuse F101- F103 on PIN205B	3	3	3BSC770010R0101	KTK-R6A/660V	for PIN205B; min.QTY 10pcs
Semiconductor fuses	3	3	DCA0012694P1	170M3815	
Cooling fan	1	1	DCA0012678P1	W2E143-AA09-25	

* DCS500/DCS600 Thyr. Modules SKKT 106 / 16E are not identical to Thyr. Modules SKKT 106 B/16E used for DCS400 Converter Modules

Module contains: 2Q 4Q

9.00 110 A (600V) CONVERTER					
DESCRIPTION	2 Q	4 Q	CODE	TYPE/DATA	NOTES
Thyristor modules	3	6	DCA0011922P1	SKKT72/20E	
Power interface board	1	1	3ADT312500R2	SDCS-PIN 206B	Repl. SDCS PIN-23 and PIN206
Fuse F101- F103 on PIN206B	3	3	3BSC770010R0101	KTK-R6A/660V	for PIN206B; min.QTY 10pcs
Semiconductor fuses	3	3	DCA0012694P1	170M3815	
Cooling fan	1	1	DCA0012678P1	W2E143-AA09-25	

Module contains: 2Q 4Q

10.00 140 A (400V-500V) CONVERTER					
DESCRIPTION	2 Q	4 Q	CODE	TYPE/DATA	NOTES
Thyristor modules	3	6	DCA0011931P1	SKKT 106/16E *	
Power interface board	1	1	3ADT312500R1	SDCS-PIN 205B	Repl. SDCS PIN-21 and PIN205
Fuse F101- F103 on PIN205B	3	3	3BSC770010R0101	KTK-R6A/660V	for PIN205B; min.QTY 10pcs
Semiconductor fuses	3	3	DCA0012694P1	170M3815	
Cooling fan	1	1	DCA0012678P1	W2E143-AA09-25	

* DCS500/DCS600 Thyr. Modules SKKT 106 / 16E are not identical to Thyr. Modules SKKT 106 B/16E used for DCS400 Converter Modules

Appendix A- Spare Parts List

Item 11.00 to 17.10 Modules DCS500B / DCS600 Size C2 200A----520A

Module contains: 2Q 4Q

11.00 200 A (400V-500V) CONVERTER					
DESCRIPTION	2 Q	4 Q	CODE	TYPE/DATA	NOTES
Thyristor modules	3	6	DCA0011931P1	SKKT 106/16E *	
Power interface board	1	1	3ADT312500R1	SDCS-PIN 205B	Repl. SDCS PIN-21 and PIN205
Fuse F101- F103 on PIN205B	3	3	3BSC770010R0101	KTK-R6A/660V	for PIN205B; min.QTY 10pcs
Semiconductor fuses	3	3	3ADC770024P9	170M3816	
Cooling fan	1	1	DCA0012171P1	W2E200-HH38-06	

* DCS500/DCS600 Thyr. Modules SKKT 106 / 16E are not identical to Thyr. Modules SKKT 106 B/16E used for DCS400 Converter Modules

Module contains: 2Q 4Q

12.00 250 A (400V-500V) CONVERTER					
DESCRIPTION	2 Q	4 Q	CODE	TYPE/DATA	NOTES
Thyristor modules	3	6	DCA0011931P1	SKKT 106/16E *	
Power interface board	1	1	3ADT312500R1	SDCS-PIN 205B	Repl. SDCS PIN-21 and PIN205
Fuse F101- F103 on PIN205B	3	3	3BSC770010R0101	KTK-R6A/660V	for PIN205B; min.QTY 10pcs
Semiconductor fuses	3	3	3ADC770024P10	170M3817	
Cooling fan	1	1	DCA0012171P1	W2E200-HH38-06	

* DCS500/DCS600 Thyr. Modules SKKT 106 / 16E are not identical to Thyr. Modules SKKT 106 B/16E used for DCS400 Converter Modules

Module contains: 2Q 4Q

13.00 270 A (600V) CONVERTER					
DESCRIPTION	2 Q	4 Q	CODE	TYPE/DATA	NOTES
Thyristor modules	3	6	DCA0011957P1	SKKT132/20E	
Power interface board	1	1	3ADT312500R2	SDCS-PIN 206B	Repl. SDCS PIN-23 and PIN206
Fuse F101- F103 on PIN206B	3	3	3BSC770010R0101	KTK-R6A/660V	for PIN206B; min.QTY 10pcs
Semiconductor fuses	3	3	DCA0003547P1	170M3819	changed in Oct.2001
Cooling fan	1	1	DCA0012171P1	W2E200-HH38-06	

Module contains: 2Q 4Q

14.00 350 A (400V-500V) CONVERTER					
DESCRIPTION	2 Q	4 Q	CODE	TYPE/DATA	NOTES
Thyristor modules	3	6	DCA0011965P1	SKKT 162 / 16E	alt.TT162N16KOF - GHSN610178P2
Power interface board	1	1	3ADT312500R1	SDCS-PIN 205B	Repl. SDCS PIN-21 and PIN205
Fuse F101- F103 on PIN205B	3	3	3BSC770010R0101	KTK-R6A/660V	for PIN205B; min.QTY 10pcs
Semiconductor fuses	3	3	DCA0012708P1	170M5810	
Cooling fan	1	1	DCA0012171P1	W2E200-HH38-06	

Module contains: 2Q 4Q

15.00 450 A (400V-500V) CONVERTER					
DESCRIPTION	2 Q	4 Q	CODE	TYPE/DATA	NOTES
Thyristor modules	3	6	DCA0011973P1	SKKT250/16E	alt.TT250N16KOF-GHSN610089P2
Power interface board	1	1	3ADT312500R1	SDCS-PIN 205B	Repl. SDCS PIN-21 and PIN205
Fuse F101- F103 on PIN205B	3	3	3BSC770010R0101	KTK-R6A/660V	for PIN205B; min.QTY 10pcs
Semiconductor fuses	3	3	DCA0012716P1	170M6811	
Cooling fan	1	1	DCA0012171P1	W2E200-HH38-06	

Module contains: 2Q 4Q

16.00 450 A (600V) CONVERTER					
DESCRIPTION	2 Q	4 Q	CODE	TYPE/DATA	NOTES
Thyristor modules	3	6	DCA0011981P1	SKKT210/20E	alt.TT250N18KOF
Power interface board	1	1	3ADT312500R2	SDCS-PIN 206B	Repl. SDCS PIN-23 and PIN206
Fuse F101- F103 on PIN206B	3	3	3BSC770010R0101	KTK-R6A/660V	for PIN206B; min.QTY 10pcs
Semiconductor fuses	3	3	DCA0012716P1	170M6811	
Cooling fan	1	1	DCA0012171P1	W2E200-HH38-06	

Module contains: 2Q 4Q

17.00 520 A (400V-500V) CONVERTER					
DESCRIPTION	2 Q	4 Q	CODE	TYPE/DATA	NOTES
Thyristor modules	3	6	DCA0011973P1	SKKT250/16E	alt.TT250N16KOF-GHSN610089P2
Power interface board	1	1	3ADT312500R1	SDCS-PIN 205B	Repl. SDCS PIN-21 and PIN205
Fuse F101- F103 on PIN205B	3	3	3BSC770010R0101	KTK-R6A/660V	for PIN205B; min.QTY 10pcs
Semiconductor fuses	3	3	DCA0012716P1	170M6811	
Cooling fan	1	1	DCA0012171P1	W2E200-HH38-06	

Module contains: 2Q 4Q

17.10 700 A (400V-500V) CONVERTER					
DESCRIPTION	2 Q	4 Q	CODE	TYPE/DATA	NOTES
Thyristor	6	12	3ADC340041P1	TZ425N16KOF	SKET400/16E - DCA 0011990P1
Power interface board	1	1	3ADT312500R1	SDCS-PIN 205B	Repl. SDCS PIN-21 and PIN205
Fuse F101- F103 on PIN205B	3	3	3BSC770010R0101	KTK-R6A/660V	for PIN205B; min.QTY 10pcs
Semiconductor fuses	3	3	DCA0012724P1	170M6813	
Cooling fan	1	1	DCA0012171P1	W2E200-HH38-06	

Appendix A- Spare Parts List

Item 18.10 to 18.30 Modules DCS500B / DCS600 Size C2b 680A----1000A

Module contains: 2Q 4Q

18.10 680 A (400V-500V) CONVERTER					
DESCRIPTION	2 Q	4 Q	CODE	TYPE/DATA	NOTES
Thyristor modules	3	6	3ADC340032P1	TT 425 N16KOF	
Power interface board	1	1	3ADT312500R1	SDCS-PIN 205B	Repl. SDCS PIN-21 and PIN205
Fuse F101- F103 on PIN205B	3	3	3BSC770010R0101	KTK-R6A/660V	for PIN205B; min.QTY 10pcs
Semiconductor fuses	3	3	DCA0012724P1	170M6813	Fuses also used for Encl. Conv.
Cooling fan	1	1	DCA0012171P1	W2E200-HH38-06	

Module contains: 2Q 4Q

18.20 820 A (400V-500V) CONVERTER					
DESCRIPTION	2 Q	4 Q	CODE	TYPE/DATA	NOTES
Thyristor modules	3	6	3ADC340066P1	TT 570 N16KOF	
Power interface board	1	1	3ADT312500R1	SDCS-PIN 205B	Repl. SDCS PIN-21 and PIN205
Fuse F101- F103 on PIN205B	3	3	3BSC770010R0101	KTK-R6A/660V	for PIN205B; min.QTY 10pcs
Semiconductor fuses/Module *	3	3	DCA0012724P1	170M6813	Fuses for Cabinets are differ.*
Cooling fan	1	1	DCA0012171P1	W2E200-HH38-06	
* Fuses used in Encl. Converter	3	3	3ADV050092P20	170M6016	Fuses for Encl. Conv. w. OESA

Module contains: 2Q 4Q

18.30 1000 A (400V-500V) CONVERTER					
DESCRIPTION	2 Q	4 Q	CODE	TYPE/DATA	NOTES
Thyristor modules	3	6	3ADC340066P1	TT 570 N16KOF	
Power interface board	1	1	3ADT312500R1	SDCS-PIN 205B	Repl. SDCS PIN-21 and PIN205
Fuse F101- F103 on PIN205B	3	3	3BSC770010R0101	KTK-R6A/660V	for PIN205B; min.QTY 10pcs
Semiconductor fuses/Module *	3	3	3ADC770010P9	170M6166	Fuses for Cabinets are differ.*
Cooling fan	1	1	3ADT754016P1	W2E250-HL06-08	
* Fuses used in Encl. Converter	3	3	3ADV050092P20	170M6016	Fuses for Encl. Conv. w. OESA

Item 19.00 to 24.00 Modules DCS500B / DCS600 Size A5 900A---2000A

19.01 Common Parts for A5 Modules					
DESCRIPTION	2 Q	4 Q	CODE	TYPE/DATA	NOTES
Temperature Sensor (R57)	1	1	3ADT710003P1	KTY 2K-M4-800	

Module contains:	2Q	4Q
------------------	----	----

19.00 900 A (600V-690V) CONVERTER					
DESCRIPTION	2 Q	4 Q	CODE	TYPE/DATA	NOTES
Thyristor	6	12	DCA0012007P1	T459N24TOF	
Puls transformer board	1	2	3BSE004939R1	SDCS-PIN-41 A	
Power interface board	1	1	3BSE004940R1	SDCS-PIN-51	
Semiconductor fuses	6	6	3ADC770009P7	170M6144	
Cooling fan	1	1	3ADT754018P1	D2E 160-AH02-15	

Module contains:	2Q	4Q
------------------	----	----

20.00 1200 A (400V-500V) CONVERTER					
DESCRIPTION	2 Q	4 Q	CODE	TYPE/DATA	NOTES
Thyristor	6	12	DCA0012015P1	T589N18TOF	
Puls transformer board	1	2	3BSE004939R1	SDCS-PIN-41 A	
Power interface board	1	1	3BSE004940R1	SDCS-PIN-51	
Semiconductor fuses	6	6	3ADC770010P5	170M6162	
Cooling fan	1	1	3ADT754018P1	D2E 160-AH02-15	

Module contains:	2Q	4Q
------------------	----	----

21.00 1500 A (400V-500V) CONVERTER					
DESCRIPTION	2 Q	4 Q	CODE	TYPE/DATA	NOTES
Thyristor	6	12	DCA0012031P1	5STP18F1800	
Puls transformer board	1	2	3BSE004939R1	SDCS-PIN-41 A	
Power interface board	1	1	3BSE004940R1	SDCS-PIN-51	
Semiconductor fuses	6	6	3ADC770010P9	170M6166	
Cooling fan	1	1	3ADT754018P1	D2E 160-AH02-15	

Module contains:	2Q	4Q
------------------	----	----

22.00 1500 A (600V-690V) CONVERTER					
DESCRIPTION	2 Q	4 Q	CODE	TYPE/DATA	NOTES
Thyristor	6	12	DCA0012023P1	5STP16F2400	
Puls transformer board	1	2	3BSE004939R1	SDCS-PIN-41 A	
Power interface board	1	1	3BSE004940R1	SDCS-PIN-51	
Semiconductor fuses	6	6	3ADC770009P12	170M6149	
Cooling fan	1	1	3ADT754018P1	D2E 160-AH02-15	

Appendix A- Spare Parts List

Module contains: 2Q 4Q

23.00 2000 A (400V-500V) CONVERTER					
DESCRIPTION	2 Q	4 Q	CODE	TYPE/DATA	NOTES
Thyristor	6	12	3ADC340074P1	5STP1818F0003	
Puls transformer board	1	2	3BSE004939R1	SDCS-PIN-41 A	
Power interface board	1	1	3BSE004940R1	SDCS-PIN-51	
Semiconductor fuses	6	6	3ADC770010P12	170M6169	
Cooling fan	1	1	3ADT754018P1	D2E 160-AH02-15	

Module contains: 2Q

24.00 2000 A (600V-690V) CONVERTER					
DESCRIPTION	2 Q		CODE	TYPE/DATA	NOTES
Thyristor	6		3ADC340075P1	5STP24H2800	
Puls transformer board	1		3BSE004939R1	SDCS-PIN-41 A	
Power interface board	1		3BSE004940R1	SDCS-PIN-51	
Semiconductor fuses	6		3ADC770009P13	170M6151	
Cooling fan	1		3ADT754018P1	D2E 160-AH02-15	

Item 19.10 to 24.10 Modules DCS500B / DCS600 Size C3 900A----2000A

Module contains: 2Q 4Q

19.10 900 A (400V-500V) CONVERTER					
DESCRIPTION	2 Q	4 Q	CODE	TYPE/DATA	NOTES
Thyristor	6	12	DCA0012015P1	T589N18TOF	
Puls transformer board	1	2	3BSE004939R1	SDCS-PIN-41 A	
Power interface board	1	1	3BSE004940R1	SDCS-PIN-51	
Semiconductor fuses	6	6	DCA0010683P1	170M6035	
Cooling fan	1	1	3ADT754006P1	RD23P-4DW.4I.1R	

Module contains: 2Q 4Q

20.10 900 A (600V-690V) CONVERTER					
DESCRIPTION	2 Q	4 Q	CODE	TYPE/DATA	NOTES
Thyristor	6	12	DCA0012007P1	T459N24TOF	
Puls transformer board	1	2	3BSE004939R1	SDCS-PIN-41 A	
Power interface board	1	1	3BSE004940R1	SDCS-PIN-51	
Semiconductor fuses	6	6	DCA0012791P1	170M6143	
Cooling fan	1	1	3ADT754006P1	RD23P-4DW.4I.1R	

Module contains: 2Q 4Q

21.10 1200 A (400V-500V) CONVERTER					
DESCRIPTION	2 Q	4 Q	CODE	TYPE/DATA	NOTES
Thyristor	6	12	DCA0012015P1	T589N18TOF	
Puls transformer board	1	2	3BSE004939R1	SDCS-PIN-41 A	
Power interface board	1	1	3BSE004940R1	SDCS-PIN-51	
Semiconductor fuses	6	6	DCA0010683P1	170M6035	
Cooling fan	1	1	3ADT754006P1	RD23P-4DW.4I.1R	

Module contains: 2Q 4Q

22.10 1500 A (400V-500V) CONVERTER					
DESCRIPTION	2 Q	4 Q	CODE	TYPE/DATA	NOTES
Thyristor	6	12	DCA0012031P1	5STP18F1800	
Puls transformer board	1	2	3BSE004939R1	SDCS-PIN-41 A	
Power interface board	1	1	3BSE004940R1	SDCS-PIN-51	
Semiconductor fuses	6	6	3ADC770010P9	170M6166	former Id. Nr.DCA0012741P1
Cooling fan	1	1	3ADT754006P1	RD23P-4DW.4I.1R	

Module contains: 2Q 4Q

23.10 1500 A (600V-690V) CONVERTER					
DESCRIPTION	2 Q	4 Q	CODE	TYPE/DATA	NOTES
Thyristor	6	12	DCA0012023P1	5STP16F2400	
Puls transformer board	1	2	3BSE004939R1	SDCS-PIN-41 A	
Power interface board	1	1	3BSE004940R1	SDCS-PIN-51	
Semiconductor fuses	6	6	DCA0012805P1	170L7299	
Cooling fan	1	1	3ADT754006P1	RD23P-4DW.4I.1R	

Module contains: 2Q 4Q

24.10 2000 A (400V-500V) CONVERTER					
DESCRIPTION	2 Q	4 Q	CODE	TYPE/DATA	NOTES
Thyristor	6	12	DCA0012031P1	5STP18F1800	
Puls transformer board	1	2	3BSE004939R1	SDCS-PIN-41 A	
Power interface board	1	1	3BSE004940R1	SDCS-PIN-51	
Semiconductor fuses	6	6	3ADC770010P9	170M6166	former Id. Nr.DCA0012741P1
Cooling fan	1	1	3ADT754006P1	RD23P-4DW.4I.1R	

Appendix A- Spare Parts List

Item 25.00 to 38.00 Modules DCS500B / DCS600 Size C4 2050A----5150A

25.00 Common Parts for C4 Modules					
DESCRIPTION	2 Q	4 Q	CODE	TYPE/DATA	NOTES
Air Flow detector (P1)	1	1	DCF1066659P1	P 33 AB	
Temperature Sensor (R57)	1	1	DCA0012139P3	KTY 10-6 M4	(C4 / 950mm cable)

Module contains: 2Q 4Q

25.10 2050 A (600V-690V-790V) CONVERTER					
DESCRIPTION	2 Q	4 Q	CODE	TYPE/DATA	NOTES
Thyristor	6	12	DCA0016142P1	5STP16F2800	
Puls transformer board	1	2	3BSE004939R1	SDCS-PIN-41 A	
Power interface board	1	1	3BSE004940R1	SDCS-PIN-51	
Semiconductor fuses	6	6	DCA0017149P1	170M7031	
*)Cooling fan (Bus Bars"Left side"	1	1	DCA0018692P1	RG35P-4DK.7M.1R	e.g. DCSxxx-2050-61L21P..
*)Cooling fan (Bus Bars"Right side"	1	1	DCA0012660P1	RG35P-4DK.7M.1L	e.g. DCSxxx-2050-61R21P..

*) Select only one Cooling Fan for this C4 Modules

Module contains: 2Q 4Q

26.00 2050 A (1000V) CONVERTER					
DESCRIPTION	2 Q	4 Q	CODE	TYPE/DATA	NOTES
Thyristor	6	12	DCA0012058P1	5STP18L3600	
Puls transformer board	1	2	3BSE004939R1	SDCS-PIN-41 A	
Power interface board	1	1	3BSE004940R1	SDCS-PIN-51	
Semiconductor fuses	6	6	DCA0012864P1	170M7510	
*)Cooling fan (Bus Bars"Left side"	1	1	DCA0018692P1	RG35P-4DK.7M.1R	e.g. DCSxxx-2050-91L21P..
*)Cooling fan (Bus Bars"Right side"	1	1	DCA0012660P1	RG35P-4DK.7M.1L	e.g. DCSxxx-2050-91R21P..

*) Select only one Cooling Fan for this C4 Modules

Module contains: 2Q 4Q

27.00 2500 A (400V-500V) CONVERTER					
DESCRIPTION	2 Q	4 Q	CODE	TYPE/DATA	NOTES
Thyristor	6	12	DCA0016169P1	5STP24L2800	
Puls transformer board	1	2	3BSE004939R1	SDCS-PIN-41 A	
Power interface board	1	1	3BSE004940R1	SDCS-PIN-51	
Semiconductor fuses	6	6	DCA0012848P1	170M7034	
*)Cooling fan (Bus Bars"Left side"	1	1	DCA0018692P1	RG35P-4DK.7M.1R	e.g. DCSxxx-2500-41L21P..
*)Cooling fan (Bus Bars"Right side"	1	1	DCA0012660P1	RG35P-4DK.7M.1L	e.g. DCSxxx-2500-41R21P..

*) Select only one Cooling Fan for this C4 Modules

Module contains:		2Q	4Q			
28.00	2500 A (600V-690V) CONVERTER					
DESCRIPTION	2 Q	4 Q	CODE	TYPE/DATA	NOTES	
Thyristor	6	12	DCA0016169P1	5STP24L2800		
Puls transformer board	1	2	3BSE004939R1	SDCS-PIN-41 A		
Power interface board	1	1	3BSE004940R1	SDCS-PIN-51		
Semiconductor fuses	6	6	DCA0012848P1	170M7034		
*)Cooling fan (Bus Bars"Left side"	1	1	DCA0018692P1	RG35P-4DK.7M.1R	e.g. DCSxxx-2500-x1L21P..	
*)Cooling fan (Bus Bars"Right side"	1	1	DCA0012660P1	RG35P-4DK.7M.1L	e.g. DCSxxx-2500-x1R21P..	

*) Select only one Cooling Fan for this C4 Modules

Module contains:		2Q	4Q			
29.00	2650 A (1000V) CONVERTER					
DESCRIPTION	2 Q	4 Q	CODE	TYPE/DATA	NOTES	
Thyristor	6	12	DCA0012058P1	5STP18L3600		
Puls transformer board	1	2	3BSE004939R1	SDCS-PIN-41 A		
Power interface board	1	1	3BSE004940R1	SDCS-PIN-51		
Semiconductor fuses	6	6	DCA0012864P1	170M7510		
*)Cooling fan (Bus Bars"Left side"	1	1	DCA0018692P1	RG35P-4DK.7M.1R	e.g. DCSxxx-2650-x1L21P..	
*)Cooling fan (Bus Bars"Right side"	1	1	DCA0012660P1	RG35P-4DK.7M.1L	e.g. DCSxxx-2650-x1R21P..	

*) Select only one Cooling Fan for this C4 Modules

Module contains:		2Q	4Q			
30.00	3200 A (790V) CONVERTER					
DESCRIPTION	2 Q	4 Q	CODE	TYPE/DATA	NOTES	
Thyristor	6	12	DCA0016169P1	5STP24L2800		
Puls transformer board	1	2	3BSE004939R1	SDCS-PIN-41 A		
Power interface board	1	1	3BSE004940R1	SDCS-PIN-51		
Semiconductor fuses	6	6	DCA0017271P1	170M7035		
*)Cooling fan (Bus Bars"Left side"	1	1	DCA0018692P1	RG35P-4DK.7M.1R	e.g. DCSxxx-3200-x1L21P..	
*)Cooling fan (Bus Bars"Right side"	1	1	DCA0012660P1	RG35P-4DK.7M.1L	e.g. DCSxxx-3200-x1R21P..	

*) Select only one Cooling Fan for this C4 Modules

Module contains:		2Q	4Q			
31.00	3200 A (1000V) CONVERTER					
DESCRIPTION	2 Q	4 Q	CODE	TYPE/DATA	NOTES	
Thyristor	6	12	DCA0012066P1	5STP28L3600		
Puls transformer board	1	2	3BSE004939R1	SDCS-PIN-41 A		
Power interface board	1	1	3BSE004940R1	SDCS-PIN-51		
Semiconductor fuses	6	6	DCA0012872P1	170M7513		
*)Cooling fan (Bus Bars"Left side"	1	1	DCA0018692P1	RG35P-4DK.7M.1R	e.g. DCSxxx-3200-x1L21P..	
*)Cooling fan (Bus Bars"Right side"	1	1	DCA0012660P1	RG35P-4DK.7M.1L	e.g. DCSxxx-3200-x1R21P..	

*) Select only one Cooling Fan for this C4 Modules

Appendix A- Spare Parts List

Module contains: 2Q 4Q

32.00 3300 A (400V-500V) CONVERTER					
DESCRIPTION	2 Q	4 Q	CODE	TYPE/DATA	NOTES
Thyristor	6	12	DCA0016169P1	5STP24L2800	
Puls transformer board	1	2	3BSE004939R1	SDCS-PIN-41 A	
Power interface board	1	1	3BSE004940R1	SDCS-PIN-51	
Semiconductor fuses	6	6	DCA0017271P1	170M7035	
*)Cooling fan (Bus Bars"Left side"	1	1	DCA0018692P1	RG35P-4DK.7M.1R	e.g. DCSxxx-3300-x1L21P..
*)Cooling fan (Bus Bars"Right side"	1	1	DCA0012660P1	RG35P-4DK.7M.1L	e.g. DCSxxx-3300-x1R21P..

*) Select only one Cooling Fan for this C4 Modules

Module contains: 2Q 4Q

33.00 3300 A (600V-690V) CONVERTER					
DESCRIPTION	2 Q	4 Q	CODE	TYPE/DATA	NOTES
Thyristor	6	12	DCA0016169P1	5STP24L2800	
Puls transformer board	1	2	3BSE004939R1	SDCS-PIN-41 A	
Power interface board	1	1	3BSE004940R1	SDCS-PIN-51	
Semiconductor fuses	6	6	DCA0017271P1	170M7035	
*)Cooling fan (Bus Bars"Left side"	1	1	DCA0018692P1	RG35P-4DK.7M.1R	e.g. DCSxxx-3300-x1L21P..
*)Cooling fan (Bus Bars"Right side"	1	1	DCA0012660P1	RG35P-4DK.7M.1L	e.g. DCSxxx-3300-x1R21P..

*) Select only one Cooling Fan for this C4 Modules

Module contains: 2Q 4Q

34.00 4000 A (400V-500V) CONVERTER					
DESCRIPTION	2 Q	4 Q	CODE	TYPE/DATA	NOTES
Thyristor	6	12	DCA0016151P1	5STP27L1800	
Puls transformer board	1	2	3BSE004939R1	SDCS-PIN-41 A	
Power interface board	1	1	3BSE004940R1	SDCS-PIN-51	
Semiconductor fuses	6	6	DCA0012821P1	170M7026	
*)Cooling fan (Bus Bars"Left side"	1	1	DCA0018692P1	RG35P-4DK.7M.1R	e.g. DCSxxx-4000-x1L21P..
*)Cooling fan (Bus Bars"Right side"	1	1	DCA0012660P1	RG35P-4DK.7M.1L	e.g. DCSxxx-4000-x1R21P..

*) Select only one Cooling Fan for this C4 Modules

Module contains: 2Q 4Q

35.00 4000 A (600V-690V-790V) CONVERTER					
DESCRIPTION	2 Q	4 Q	CODE	TYPE/DATA	NOTES
Thyristor	6	12	DCA0016177P1	5STP33L2800	
Puls transformer board	1	2	3BSE004939R1	SDCS-PIN-41 A	
Power interface board	1	1	3BSE004940R1	SDCS-PIN-51	
Semiconductor fuses	6	6	DCA0012856P1	170M7036	
*)Cooling fan (Bus Bars"Left side"	1	1	DCA0018692P1	RG35P-4DK.7M.1R	e.g. DCSxxx-4000-x1L21P..
*)Cooling fan (Bus Bars"Right side"	1	1	DCA0012660P1	RG35P-4DK.7M.1L	e.g. DCSxxx-4000-x1R21P..

*) Select only one Cooling Fan for this C4 Modules

Module contains:		2Q	4Q			
36.00	4000 A (1000V) CONVERTER					
DESCRIPTION	2 Q	4 Q	CODE	TYPE/DATA	NOTES	
Thyristor	6	12	DCA0012082P1	5STP38N3600		
Puls transformer board	1	2	3BSE004939R1	SDCS-PIN-41 A		
Power interface board	1	1	3BSE004940R1	SDCS-PIN-51		
Semiconductor fuses	6	6	DCA0012881P1	170M7520		
*)Cooling fan (Bus Bars"Left side"	1	1	DCA0018692P1	RG35P-4DK.7M.1R	e.g. DCSxxx-4000-x1L21P..	
*)Cooling fan (Bus Bars"Right side"	1	1	DCA0012660P1	RG35P-4DK.7M.1L	e.g. DCSxxx-4000-x1R21P..	

*) Select only one Cooling Fan for this C4 Modules

Module contains:		2Q	4Q			
37.00	4750 A (600V-690V-790V) CONVERTER					
DESCRIPTION	2 Q	4 Q	CODE	TYPE/DATA	NOTES	
Thyristor	6	12	DCA0016193P1	5STP45N2800		
Puls transformer board	1	2	3BSE004939R1	SDCS-PIN-41 A		
Power interface board	1	1	3BSE004940R1	SDCS-PIN-51		
Semiconductor fuses	6	6	DCA0012856P1	170M7036		
*)Cooling fan (Bus Bars"Left side"	1	1	DCA0018692P1	RG35P-4DK.7M.1R	e.g. DCSxxx-4750-x1L21P..	
*)Cooling fan (Bus Bars"Right side"	1	1	DCA0012660P1	RG35P-4DK.7M.1L	e.g. DCSxxx-4750-x1R21P..	

*) Select only one Cooling Fan for this C4 Modules

Module contains:		2Q	4Q			
38.00	5150 A (400 V-500 V) CONVERTER					
DESCRIPTION	2 Q	4 Q	CODE	TYPE/DATA	NOTES	
Thyristor	6	12	DCA0016185P1	5STP45N2200		
Puls transformer board	1	2	3BSE004939R1	SDCS-PIN-41 A		
Power interface board	1	1	3BSE004940R1	SDCS-PIN-51		
Semiconductor fuses	6	6	DCA0012830P1	170M7028		
*)Cooling fan (Bus Bars"Left side"	1	1	DCA0018692P1	RG35P-4DK.7M.1R	e.g. DCSxxx-5150-x1L21P..	
*)Cooling fan (Bus Bars"Right side"	1	1	DCA0012660P1	RG35P-4DK.7M.1L	e.g. DCSxxx-5150-x1R21P..	

*) Select only one Cooling Fan for this C4 Modules

If you have any questions concerning spare parts, please contact your local ABB-agent!



ABB Automation Products GmbH
Postfach 1180
68619 Lampertheim • GERMANY
Tel: +49 (0) 62 06-5 03-0
Fax: +49 (0) 62 06-5 03-6 09
www.abb.com/dc



093R0601A2270000

Ident. No.: 3ADW 000 093 R0601 Rev F
07_2002