



Compact 32-point Solid-state 24V dc Sink Output Module

Catalog Number 1769-OV32T

Use this document as a guide when installing a Compact 32-point solid-state 24V dc sink output module.

Topic	Page
Important User Information	2
Module Description	3
Module Installation	4
System Assembly	5
Mounting Expansion I/O	6
Replacing a Single Module within a System	8
Field Wiring Connections	9
I/O Memory Mapping	14
1769-OV32T Configuration File	15
Spare/Replacement Module Parts	16
Specifications	17
Hazardous Location Considerations	20
For More Information	21

Important User Information



Because of the variety of uses for the products described in this publication, those responsible for the application and use of these products must satisfy themselves that all necessary steps have been taken to assure that each application and use meets all performance and safety requirements, including any applicable laws, regulations, codes and standards. In no event will Rockwell Automation be responsible or liable for indirect or consequential damage resulting from the use or application of these products.

Any illustrations, charts, sample programs, and layout examples shown in this publication are intended solely for purposes of example. Since there are many variables and requirements associated with any particular installation, Rockwell Automation does not assume responsibility or liability (to include intellectual property liability) for actual use based upon the examples shown in this publication.

Allen-Bradley publication SGI-1.1, *Safety Guidelines for the Application, Installation and Maintenance of Solid-State Control* (available from your local Rockwell Automation office), describes some important differences between solid-state equipment and electromechanical devices that should be taken into consideration when applying products such as those described in this publication.

Reproduction of the contents of this copyrighted publication, in whole or part, without written permission of Rockwell Automation, is prohibited.

Throughout this publication, notes may be used to make you aware of safety considerations. The following annotations and their accompanying statements help you to identify a potential hazard, avoid a potential hazard, and recognize the consequences of a potential hazard:

<p>WARNING</p> 	<p>Identifies information about practices or circumstances that can cause an explosion in a hazardous environment, which may lead to personal injury or death, property damage, or economic loss.</p>
<p>ATTENTION</p> 	<p>Identifies information about practices or circumstances that can lead to personal injury or death, property damage, or economic loss.</p>
<p>IMPORTANT</p>	<p>Identifies information that is critical for successful application and understanding of the product.</p>

Module Description

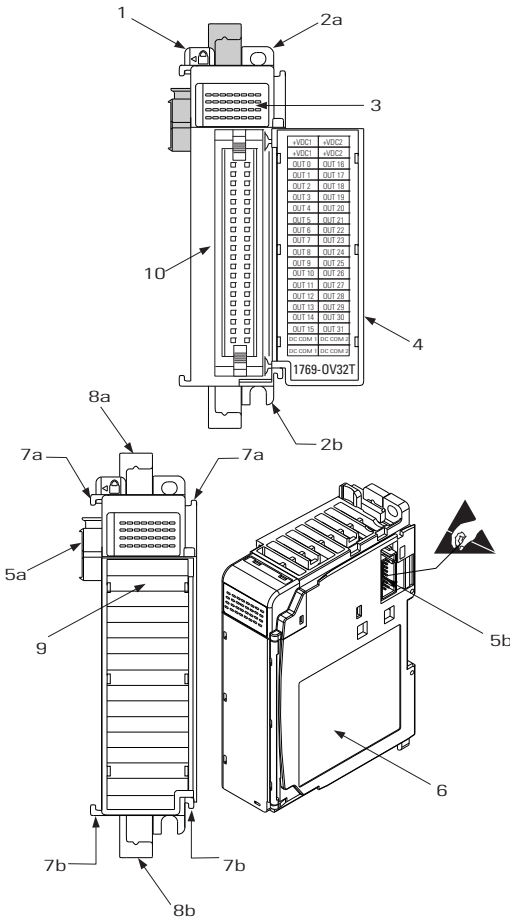

Item	Description
1	bus lever (with locking function)
2a	upper panel mounting tab
2b	lower panel mounting tab
3	I/O diagnostic LEDs
4	module door with terminal identification label
5a	movable bus connector with female pins
5b	stationary bus connector with male pins
6	nameplate label
7a	upper tongue-and-groove slots
7b	lower tongue-and-groove slots
8a	upper DIN rail latch
8b	lower DIN rail latch
9	write-on label (user ID tag)
10	MIL-C-83503 connector

31563A-M

Module Installation

Compact I/O is suitable for use in an industrial environment when installed in accordance with these instructions. Specifically, this equipment is intended for use in clean, dry environments (Pollution degree 2⁽¹⁾) and to circuits not exceeding Over Voltage Category II⁽²⁾ (IEC 60664-1).⁽³⁾

Prevent Electrostatic Discharge

ATTENTION



Electrostatic discharge can damage integrated circuits or semiconductors if you touch bus connector pins. Follow these guidelines when you handle the module:

- Touch a grounded object to discharge static potential.
- Wear an approved wrist-strap grounding device.
- Do not touch the bus connector or connector pins.
- Do not touch circuit components inside the module.
- If available, use a static-safe work station.
- When not in use, keep the module in its static-shield box.

Remove Power

ATTENTION



Remove power before removing or inserting this module. When you remove or insert a module with power applied, an electrical arc may occur. An electrical arc can cause personal injury or property damage by:

- sending an erroneous signal to your system's field devices, causing unintended machine motion
- causing an explosion in a hazardous environment

Electrical arcing causes excessive wear to contacts on both the module and its mating connector. Worn contacts may create electrical resistance.

⁽¹⁾ Pollution Degree 2 is an environment where, normally, only non-conductive pollution occurs except that occasionally a temporary conductivity caused by condensation shall be expected.

⁽²⁾ Over Voltage Category II is the load level section of the electrical distribution system. At this level transient voltages are controlled and do not exceed the impulse voltage capability of the product's insulation.

⁽³⁾ Pollution Degree 2 and Over Voltage Category II are International Electrotechnical Commission (IEC) designations.

System Assembly

The module can be attached to the controller or an adjacent I/O module *before or after* mounting. For mounting instructions, see Panel Mounting on page 6, or DIN Rail Mounting on page 8. To work with a system that is already mounted, see Replacing a Single Module within a System on page 8.

The following procedure shows you how to assemble the Compact I/O system.

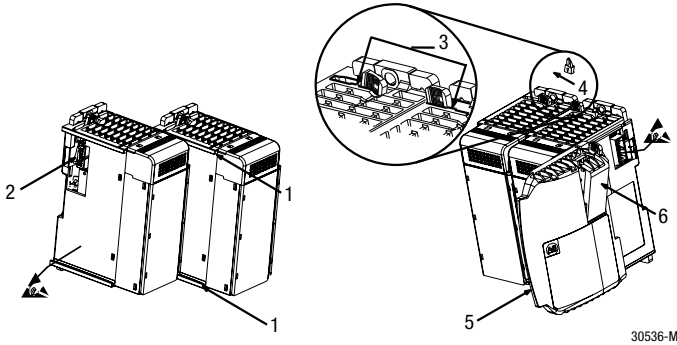

1. Disconnect power.
2. Check that the bus lever of the module to be installed is in the unlocked (fully right) position.
3. Use the upper and lower tongue-and-groove slots (1) to secure the modules together (or to a controller).
4. Move the module back along the tongue-and-groove slots until the bus connectors (2) line up with each other.
5. Push the bus lever back slightly to clear the positioning tab (3). Use your fingers or a small screw driver.
6. To allow communication between the controller and module, move the bus lever fully to the left (4) until it clicks. Ensure it is locked firmly in place.

ATTENTION



When attaching I/O modules, it is very important that the bus connectors are securely locked together to ensure proper electrical connection.

6 Compact 32-point Solid-state 24V dc Sink Output Module

7. Attach an end cap terminator (5) to the last module in the system by using the tongue-and-groove slots as before.
8. Lock the end cap bus terminator (6).

IMPORTANT

A 1769-ECR or 1769-ECL right or left end cap must be used to terminate the end of the serial communication bus.

Mounting Expansion I/O

ATTENTION



During panel or DIN rail mounting of all devices, be sure that all debris (metal chips, wire strands, etc.) is kept from falling into the module. Debris that falls into the module could cause damage on power up.

Minimum Spacing

Maintain spacing from enclosure walls, wireways, adjacent equipment, etc. Allow 50 mm (2 in.) of space on all sides for adequate ventilation, as shown:

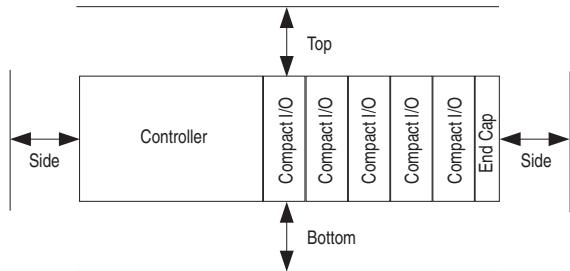

Panel Mounting

Mount the module to a panel using two screws per module. Use M4 or #8 panhead screws. Mounting screws are required on every module.

Panel Mounting Using the Dimensional Template

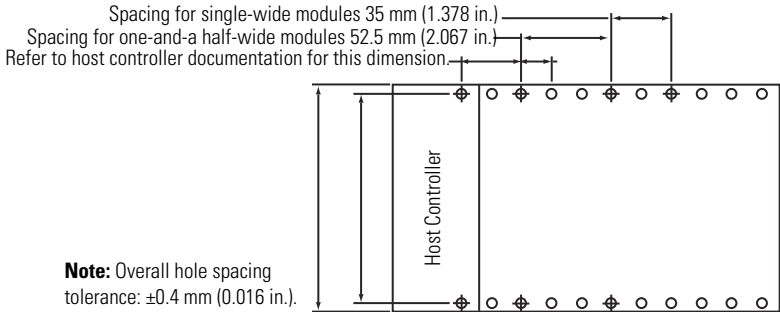

Locate holes every 17.5 mm (0.689 in.) to allow for a mix of single-wide and one-and-a-half-wide modules (e.g. 1769-OA16).

Panel Mounting Procedure Using Modules as a Template

The following procedure allows you to use the assembled modules as a template for drilling holes in the panel. If you have sophisticated panel mounting equipment, you can use the dimensional template provided on page 7. Due to module mounting hole tolerance, it is important to follow these procedures:

1. On a clean work surface, assemble no more than three modules.
2. Using the assembled modules as a template, carefully mark the center of all module-mounting holes on the panel.
3. Return the assembled modules to the clean work surface, including any previously mounted modules.
4. Drill and tap the mounting holes for the recommended M4 or #8 screw.
5. Place the modules back on the panel, and check for proper hole alignment.
6. Attach the modules to the panel using the mounting screws.

TIP

If mounting more modules, mount only the last one of this group and put the others aside. This reduces remounting time during drilling and tapping of the next group.

7. Repeat steps 1 to 6 for any remaining modules.

DIN Rail Mounting

The module can be mounted using these DIN rails:

35 x 7.5 mm (EN 50 022 - 35 x 7.5) or 35 x 15 mm (EN 50 022 - 35 x 15).

Before mounting the module on a DIN rail, close the DIN rail latches. Press the DIN rail mounting area of the module against the DIN rail. The latches will momentarily open and lock into place.

Replacing a Single Module within a System

The module can be replaced while the system is mounted to a panel (or DIN rail).

1. Remove power. See important note on page 4.
2. On the module to be removed, remove the upper and lower mounting screws from the module (or open the DIN latches using a flat-blade or phillips style screw driver).
3. Move the bus lever to the right to disconnect (unlock) the bus.
4. On the right-side adjacent module, move its bus lever to the right (unlock) to disconnect it from the module to be removed.
5. Gently slide the disconnected module forward. If you feel excessive resistance, check that the module has been disconnected from the bus, and that both mounting screws have been removed (or DIN latches opened).

TIP

It may be necessary to rock the module slightly from front to back to remove it, or, in a panel-mounted system, to loosen the screws of adjacent modules.

6. Before installing the replacement module, be sure that the bus lever on the module to be installed, and on the right-side adjacent module are in the unlocked (fully right) position.
7. Slide the replacement module into the open slot.
8. Connect the modules together by locking (fully left) the bus levers on the replacement module and the right-side adjacent module.
9. Replace the mounting screws (or snap the module onto the DIN rail).

Field Wiring Connections

Grounding the Module

This product is intended to be mounted to a well-grounded mounting surface such as a metal panel. Additional grounding connections from the module's mounting tabs or DIN rail (if used), are not required unless the mounting surface cannot be grounded. Refer to *Industrial Automation Wiring and Grounding Guidelines*, Allen-Bradley publication 1770-4.1, for additional information.

Output Wiring

Basic wiring⁽¹⁾ of output devices⁽²⁾ to the 1769-OV32T is shown below.

ATTENTION



- Miswiring of the module to an AC power sink or applying reverse polarity will damage the module.
- Be careful when stripping wires. Wire fragments that fall into a module could cause damage at power up. Once wiring is complete, ensure the module is free of all metal fragments.

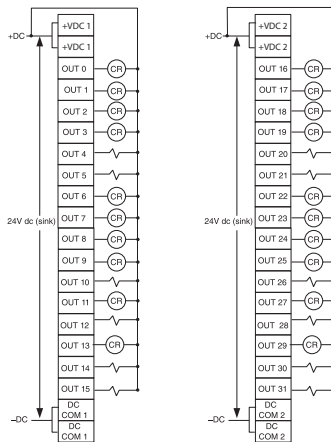

⁽¹⁾ Recommended Surge Suppression - Use a 1N4004 diode reverse-wired across the load for transistor outputs switching 24V dc inductive loads. For additional details, refer to *Industrial Automation Wiring and Grounding Guidelines*, Allen-Bradley publication 1770-4.1.

⁽²⁾ Sinking Output - sink describes the current flow between the I/O module and the field device. Sinking output circuits sink current from sourcing field devices. Field devices connected to the negative side (DC Common) of the field power supply are sinking field devices. Field devices connected to the positive side (+V) of the field supply are sourcing field devices. Europe: DC sinking input and sourcing output module circuits are the commonly used options.

Simplified Output Circuit Diagram

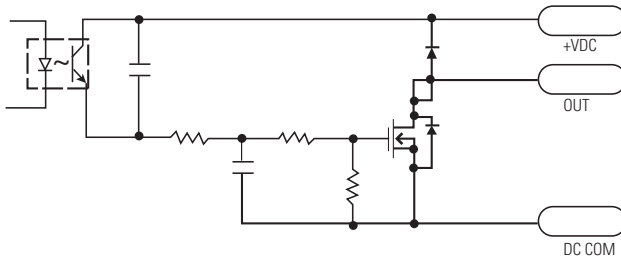

31560A-M

Wiring Options for the I/O Module

Included with your 32-point I/O module is a keyed 40-pin female connector and crimp type pins. These components allow you to wire I/O devices to the module using a 40-conductor cable or individual wires. Refer to page 12 for connector/pin assembly instructions. When assembled, align the female connector over the module's male header using the keying slot as a guide. Firmly lock them together with the upper and lower retaining arms. 1492 pre-wired cables and interface modules can be used for connecting external I/O.

There are two options for wiring the 32-point I/O module.

Option 1 - Wiring the 1746-N3 Connector

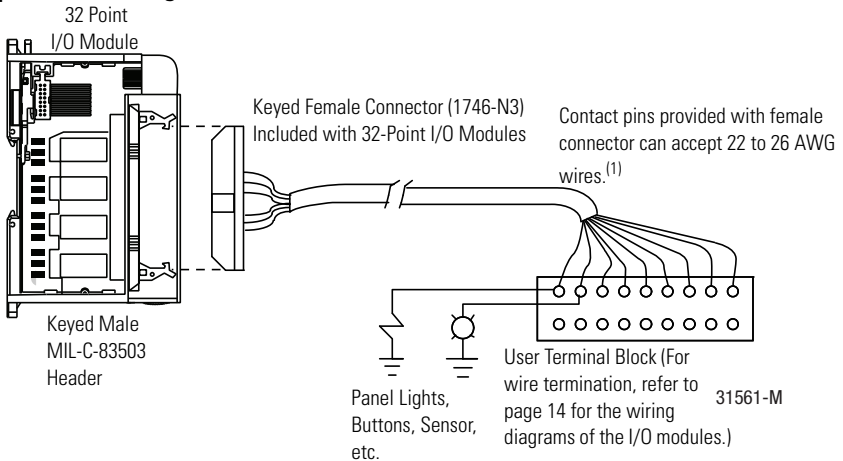

(1) Maximum user cable length is dependent on how much voltage drop (current x ohms/ft.) x (feet) the user's system can tolerate. The user's system should take into account the minimum turn-on voltage required by external loads connected to the 32-point output module, the minimum turn-on voltage required by the 32-point input module, and all of the voltage drops associated with wiring to and from the load, sensors, terminal blocks, power sources and the module itself.

Option 2 - Using Allen-Bradley 1492 Wiring Systems

Allen-Bradley 1492 wiring systems are available for connecting 32 point I/O modules to external I/O. These wiring systems include a pre-wired cable available in four lengths: 0.5m (1.6 feet), 1.0m (3.3 feet), 2.5m (8.2 feet), 5.0m (16.4 feet). An Interface Module for connecting external devices is also available. Cables are equipped with keyed connectors at both ends for proper connections. Interface modules are DIN rail mountable and are available with or without field side status indicating LEDs. Stick-on labels are provided with the Interface modules to identify I/O wiring termination points.

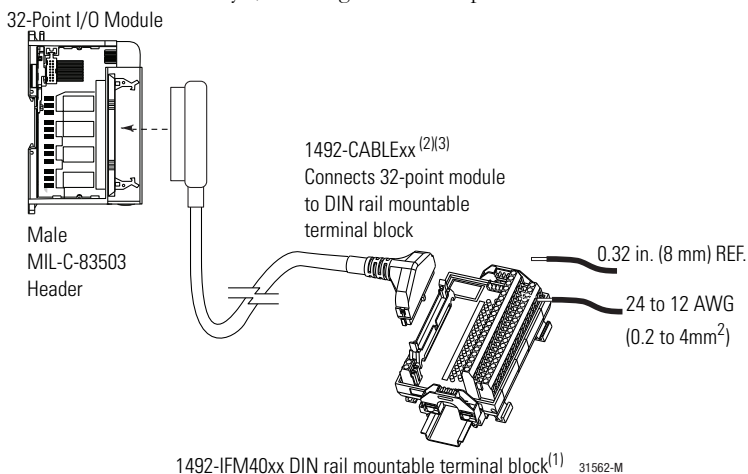

- (1) To maintain group isolation provided by 32-point I/O modules, use a 1492 terminal block that provides group isolation. Consult 1492 documentation or your Allen-Bradley Sales Office for additional information.
- (2) Maximum user cable length is dependent on how much voltage drop (current x (ohms/ft.) x (feet)) the user's system can tolerate. The user's system should take into account the minimum turn-on voltage required by external loads connected to the 32-point output module, the minimum turn-on voltage required by the 32-point input module, and all of the voltage drops associated with wiring to and from the load, sensors, terminal blocks, power sources and the module itself. See the table on page 11 for voltage drop values for the 1492 cables shown above.
- (3) When using 1492-CABLExx, I/O module door will not be able to be closed. Leave open or detach removable door.

Catalog No.	Voltage Drop at 30°C		Voltage Drop at 60°C	
	V dc and dc com Wires ⁽¹⁾	Output Channel Wires ⁽²⁾	V dc and dc com Wires	Output Channel Wires
1492-CABLE005H	127 mv	34 mv	144 mv	38 mv
1492-CABLE010H	173 mv	45 mv	196 mv	51 mv
1492-CABLE025H	334 mv	83 mv	388 mv	95 mv
1492-CABLE050H	574 mv	147 mv	686 mv	169 mv

(1) Voltage drop at maximum rated current of 2 amps per conductor.

(2) Voltage drop at maximum rated current of 0.5 amps per output channel.

Labeling for the 1492 Interface Module

Several different stick-on label sets are provided on a single card with 1492 Interface Modules. Each label set is identified with an I/O module catalog number and words “upper” and “lower” to identify which terminal strip the label should be affixed to.

The table below identifies the 1769-OV32T 32-point labels and their location on the interface module. Peel off the appropriate label and apply it to the interface module.

Terminal Block Labels	
Bottom Terminal Block	Top Terminal Block
+V1	+V2
+V1	+V2
0	16
1	17
2	18
3	19
4	20
5	21
6	22
7	23
8	24
9	25
10	26
11	27
12	28
13	29
14	30
15	31
CM1	CM2
CM1	CM2

The stick-on labels of the 1492 Interface Module are abbreviated as follows: +V1 = V dc 1, +V2 = V dc 2, CM1 = Com 1, etc.

TIP

If you decide to build your cable using another 1746-N3 to terminate the cable at the 1492 Interface Module end, wire it in the following manner: Pin 1 to Pin 1, Pin 2 to Pin 2, Pin 3 to Pin 3, etc.

NOTE: If the stick-on label set for the 1769-OV32T module is not available, use the 1492 interface module stick-on label set for 1746-OB32 modules.

Assemble the Wire Contacts

1. Strip the wire insulation as shown in Figure 1. Crimp pins can accept 22 to 26 AWG wire.
2. Insert the wire up to the wire stop as shown in Figure 2.
3. Crimp with DDK crimp tool 357J-5538. Equivalent Amp part numbers are: pin - #87666-2, connector - #102387-9, and crimp tool - #90418-1.

TIP

Pins and connectors from different manufacturers cannot be assembled together. For example, Amp pins cannot be used with a DDK connector.

If a crimp tool is not available, use the following crimping procedure:

- a. Crimp the wire barrel around the wire using small needle nose pliers.
 - b. Crimp the insulation barrel around the wire insulation using small needle nose pliers.
 - c. Solder wire and wire barrel together using rosin core (60% tin/ 40% lead) solder and soldering pencil.
4. Insert the wire contact into the socket as shown in Figure 3 and 4. Check to make sure that the tang, shown as "A" in Figure 4, is properly latched by lightly pulling on the wire.

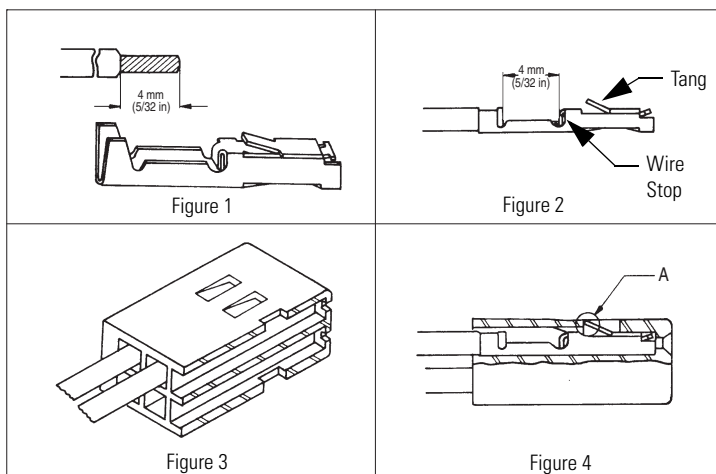

I/O Memory Mapping

Output Data File

For each module, slot x, words 0-1 in the output data file contain the control program's directed state of the discrete output points.

Word	Bit Position															
	15	14	13	12	11	10	9	8	7	6	5	4	3	2	1	0
0	w	w	w	w	w	w	w	w	w	w	w	w	w	w	w	w
1	w	w	w	w	w	w	w	w	w	w	w	w	w	w	w	w

w = write

Output Module's Input Data File

For each module, slot x, input data file words 0-1 contain the state of the module's output data (output data echo) file words 0-1. During normal operation, these input bits represent the logic state that the outputs are directed to by the control program. They are also dependent upon the:

- Program Mode configuration (if supported by the controller)
- The Fault Mode configuration (if supported by the controller)

Word	Bit Position															
	15	14	13	12	11	10	9	8	7	6	5	4	3	2	1	0
0	r	r	r	r	r	r	r	r	r	r	r	r	r	r	r	r
1	r	r	r	r	r	r	r	r	r	r	r	r	r	r	r	r

r = read

IMPORTANT

The output module's input data file reflects the output data echo of the module, not necessarily the electrical state of the output terminals. It does not reflect shorted or open outputs.

It is important to use this input word if the controller adapter supports the Program Mode or Fault Mode function, and if it is configured to use them.

1769-OV32T Configuration File

The read/writable configuration data file allows the setup of the hold last state and user-defined safe state conditions.

The manipulation of the bits from this file is normally done with programming software (e.g., RSLogix 500, RSNetWorx for DeviceNet, etc.) during initial configuration of the system. In that case, graphical screens are provided via the programmer to simplify configuration.

However, some systems (e.g., 1769-ADN DeviceNet Adapter) also allow the bits to be altered as part of the control program using communication rungs. In that case, it is necessary to understand the bit arrangement.

Word	Bit Position																
	15	14	13	12	11	10	9	8	7	6	5	4	3	2	1	0	
0	0	0	0	0	0	0	0	0	0	0	0	0	0	0	0	0	PFE
1	0	0	0	0	0	0	0	0	0	0	0	0	0	0	0	0	0
2	Program State for Output Array Word 0																
3	Program State for Output Array Word 1																
4	Program Value for Output Array Word 0																
5	Program Value for Output Array Word 1																
6	Fault State for Output Array Word 0																
7	Fault State for Output Array Word 1																
8	Fault Value for Output Array Word 0																
9	Fault Value for Output Array Word 1																
10	0	0	0	0	0	0	0	0	0	0	0	0	0	0	0	0	0
11	0	0	0	0	0	0	0	0	0	0	0	0	0	0	0	0	0
12	0	0	0	0	0	0	0	0	0	0	0	0	0	0	0	0	0
13	0	0	0	0	0	0	0	0	0	0	0	0	0	0	0	0	0
14	0	0	0	0	0	0	0	0	0	0	0	0	0	0	0	0	0
15	0	0	0	0	0	0	0	0	0	0	0	0	0	0	0	0	0

Program State Word

Word 1, the program state word, selects the hold last state or user-defined safe state condition for each individual output on a system transition from Run to Program.

Condition	Bit Setting
User-defined Safe State	0
Hold Last State	1

Program Value Word

The program value word, word 2, is used to program the user-defined safe state value (0=Off, 1=On). Each output is individually configurable for on or off.

Value	Bit Setting
Off	0
On	1

Fault State Word

Word 3, the fault state word, selects the hold last state or user-defined safe state condition for each individual output on a system transition from Run to Fault.

Condition	Bit Setting
User-defined Safe State	0
Hold Last State	1

Fault Value Word

The fault value word, word 4, is used to program the fault state value (0=Off, 1=On). Each output is individually configurable for on or off.

Value	Bit Setting
Off	0
On	1

Program to Fault Enable Bit (PFE)

Word 0, bit 0, allows the selection of which data value, the program or fault value, to apply to the output if a system in Program mode undergoes a system fault, resulting a change to Fault mode.

Value Applied	Bit Setting
Program	0
Fault	1

Module Default Condition

The modules default condition is all zeros, programming the conditions shown.

Word or Bit Affected	Condition Applied
Word 0, Bit 0:	Program-to-Fault Enable
Word 1:	Program State
Word 2:	Program Value
Word 3:	Fault State
Word 4:	Fault Value

Spare/Replacement Module Parts

- 1746-N3: Connector kit (1 connector, 40 terminals per kit)

Specifications

General Specifications

Specification	Value
Dimensions	118 mm (height) x 87 mm (depth) x 35 mm (width) height including mounting tabs is 138 mm 4.65 in. (height) x 3.43 in (depth) x 1.38 in (width) height including mounting tabs is 5.43 in.
Approximate Shipping Weight (with carton)	230 g (0.51 lbs)
Storage Temperature	-40°C to +85°C (-40°F to +185°F)
Operating Temperature	0°C to +60°C (32°F to +140°F)
Operating Humidity	5% to 95% non-condensing
Operating Altitude	2000 meters (6561 feet)
Vibration	Operating: 10 to 500 Hz, 5G, 0.030 inches maximum peak-to-peak
Shock	Operating: 30G panel mounted (20G DIN rail mounted) Non-Operating: 40G panel mounted (30G DIN rail mounted)
Agency Certification	<ul style="list-style-type: none"> • C-UL certified (under CSA C22.2 No. 142) • UL 508 listed • CE and C-Tick compliant for all applicable directives
Hazardous Environment Class	Class I, Division 2, Hazardous Location, Groups A, B, C, D (UL 1604, C-UL under CSA C22.2 No. 213)
Radiated and Conducted Emissions	EN50081-2 Class A
<i>Electrical /EMC:</i>	<i>The module has passed testing at the following levels:</i>
ESD Immunity (IEC61000-4-2)	<ul style="list-style-type: none"> • 4kV contact, 8 kV air, 4 kV indirect
Radiated Immunity (IEC61000-4-3)	<ul style="list-style-type: none"> • 10 V/m, 80 to 1000 MHz, 80% amplitude modulation
Fast Transient Burst (IEC61000-4-4)	<ul style="list-style-type: none"> • 2 kV, 5 kHz
Surge Immunity (IEC61000-4-5)	<ul style="list-style-type: none"> • 2 kV common mode, 1 kV differential mode
Conducted Immunity (IEC61000-4-6)	<ul style="list-style-type: none"> • 10V, 0.15 to 80 MHz⁽¹⁾

⁽¹⁾ Conducted Immunity frequency range may be 150 kHz to 30 MHz if the Radiated Immunity frequency range is 30 MHz to 1000 MHz.

Output Specifications

Specification	1769-0V32T
Voltage Category	24V dc
Operating Voltage Range	10.2V dc to 26.4V dc (sink ⁽¹⁾)
Number of Outputs	32
Bus Current Draw (max.)	220 mA at 5V dc (0.85 W)
Heat Dissipation	4.76 Total Watts (The Watts per point, plus the minimum Watts, with all points energized.)
Signal Delay (max.) – resistive load	Operating voltage < 16V: turn-on = 1.5 ms Operating voltage ≥ 16V: turn-on = 1.0 ms Turn-off = 4.0 ms
Off-State Leakage (max.) ⁽²⁾	1.0 mA at 26.4V dc
On-State Current (min.)	1.0 mA
On-State Voltage Drop (max.)	0.3V dc at 0.5 A
Continuous Current Per Point (max.)	0.5A
Continuous Current Per Common (max.)	2.0A
Continuous Current Per Module (max.)	4.0A
Surge Current (max.) ⁽³⁾	2.0A (Repeatability is once every 2 seconds for a duration of 10 msec.)
Power Supply Distance Rating	8 (The module may not be more than 8 modules away from the power supply.)
Output Point to Bus Isolation	Verified by one of the following dielectric tests: 1200V ac for 1 sec. or 1697V dc for 1 sec. 75V dc working voltage (IEC Class 2 reinforced insulation)
Isolated Groups	Group 1: outputs 0 to 15 (internally connected to DC COM 1) Group 2: outputs 16 to 31 (internally connected to DC COM 2)
Vendor I.D. Code	1
Product Type Code	7
Product Code	75

⁽¹⁾ Sinking Output - sink describes the current flow between the I/O module and the field device. Sinking output circuits sink current from sourcing field devices. Field devices connected to the negative side (DC Common) of the field power supply are sinking field devices. Field devices connected to the positive side (+V) of the field supply are sourcing field devices. *Europe:* DC sinking input and sourcing output module circuits are the commonly used options.

⁽²⁾ **Typical Loading Resistor** - To limit the effects of leakage current through solid state outputs, a loading resistor can be connected in parallel with your load. Use a 5.6K ohm, ½ watt resistor for transistor outputs, 24V dc operation.

⁽³⁾ Recommended Surge Suppression - Use a 1N4004 diode reverse-wired across the load for transistor outputs switching 24V dc inductive loads. For additional details, refer to Industrial Automation Wiring and Grounding Guidelines, Allen-Bradley publication 1770-4.1.

Transistor Output Transient Pulses

The maximum duration of the transient pulse occurs when minimum load is connected to the output. However, for most applications, the energy of the transient pulse is not sufficient to energize the load.

ATTENTION



A transient pulse occurs in transistor outputs when the external DC supply voltage is applied to the output common terminals (e.g. via the master control relay). The sudden application of voltage creates this transient pulse. This condition is inherent in transistor outputs and is common to solid state devices. A transient pulse can occur regardless of the controller having power or not. Refer to your controller's user manual to reduce inadvertent operation.

The graph below illustrates that the duration of the transient is proportional to the load current. Therefore, as the on-state load current increases, the transient pulse decreases. Power-up transients do not exceed the time duration shown below, for the amount of loading indicated, at 60°C (140°F).

Transient Pulse Duration as a Function of Load Current

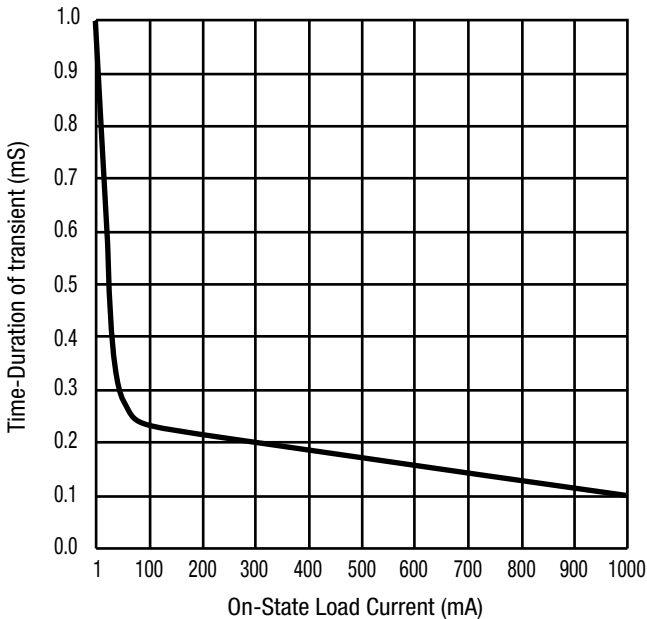

30519-M

Hazardous Location Considerations

This equipment is suitable for use in Class I, Division 2, Groups A, B, C, D or non-hazardous locations only. The following WARNING statement applies to use in hazardous locations.

WARNING



EXPLOSION HAZARD

- Substitution of components may impair suitability for Class I, Division 2.
 - Do not replace components or disconnect equipment unless power has been switched off or the area is known to be non-hazardous.
 - Do not connect or disconnect components unless power has been switched off or the area is known to be non-hazardous.
 - This product must be installed in an enclosure.
 - All wiring must comply with N.E.C. article 501-4(b).
-

Environnements dangereux

Cet équipement est conçu pour être utilisé dans des environnements de Classe 1, Division 2, Groupes A, B, C, D ou non dangereux. La mise en garde suivante s'applique à une utilisation dans des environnements dangereux.

AVERTISSEMENT



DANGER D'EXPLOSION

- La substitution de composants peut rendre cet équipement impropre à une utilisation en environnement de Classe 1, Division 2.
 - Ne pas remplacer de composants ou déconnecter l'équipement sans s'être assuré que l'alimentation est coupée et que l'environnement est classé non dangereux.
 - Ne pas connecter ou déconnecter des composants sans s'être assuré que l'alimentation est coupée ou que l'environnement est classé non dangereux.
 - Ce produit doit être installé dans une armoire.
-

For More Information

For	Refer to this Document	Pub. No.
A more detailed description of how to install and use your Compact™ I/O with MicroLogix™ 1200 & 1500 programmable controller.	MicroLogix 1200 & 1500 Programmable Controllers User Manual	1764-UM001
A more detailed description of how to install and use your Compact I/O with the 1769-ADN DeviceNet Adapter.	1769-ADN DeviceNet Adapter User Manual	1769-UM001
A more detailed description of how to install and use your Compact I/O with the CompactLogix™ System.	CompactLogix System User Manual	1769-UM007
More information on proper wiring and grounding techniques.	Industrial Automation Wiring and Grounding Guidelines	1770-4.1

If you would like a manual, you can:

- download a free electronic version from the internet:
www.ab.com/micrologix or **www.ab.com/literature**
- purchase a printed manual by:
 - contacting your local distributor or Rockwell Automation representative
 - calling 1.800.963.9548 (USA/Canada)
or 001.330.725.1574 (Outside USA/Canada)

Compact, MicroLogix, CompactLogix, RSLogix 500, and RSNetWorx for DeviceNet are trademarks of Rockwell Automation. DeviceNet is a trademark of Open DeviceNet Vendor Association (ODVA).

Rockwell Automation Support

Rockwell Automation provides technical information on the web to assist you in using its products. At <http://support.rockwellautomation.com>, you can find technical manuals, a knowledge base of FAQs, technical and application notes, sample code and links to software service packs, and a MySupport feature that you can customize to make the best use of these tools.

For an additional level of technical phone support for installation, configuration and troubleshooting, we offer TechConnect Support programs. For more information, contact your local distributor or Rockwell Automation representative, or visit <http://support.rockwellautomation.com>.

Installation Assistance

If you experience a problem with a hardware module within the first 24 hours of installation, please review the information that's contained in this manual. You can also contact a special Customer Support number for initial help in getting your module up and running:

United States	1.440.646.3223 Monday – Friday, 8am – 5pm EST
Outside United States	Please contact your local Rockwell Automation representative for any technical support issues.

New Product Satisfaction Return

Rockwell tests all of its products to ensure that they are fully operational when shipped from the manufacturing facility. However, if your product is not functioning and needs to be returned:

United States	Contact your distributor. You must provide a Customer Support case number (see phone number above to obtain one) to your distributor in order to complete the return process.
Outside United States	Please contact your local Rockwell Automation representative for return procedure.

www.rockwellautomation.com

Power, Control and Information Solutions Headquarters

Americas: Rockwell Automation, 1201 South Second Street, Milwaukee, WI 53204-2496 USA, Tel: (1) 414.382.2000, Fax: (1) 414.382.4444

Europe/Middle East/Africa: Rockwell Automation, Vorstlaan/Boulevard du Souverain 36, 1170 Brussels, Belgium, Tel: (32) 2 663 0600, Fax: (32) 2 663 0640

Publication 1769-IN073B-EN-P - September 2005

1769-IN073A-EN-P June 2005

PN 40071-195-01(2)

Copyright © 2005 Rockwell Automation, Inc. All rights reserved. Printed in the U.S.A.

