



***Allen-Bradley***

***Bulletin 1336 FORCE  
Adjustable Frequency  
AC Drive  
Series B, C, D***

***B150 – B250  
C150 – C250***

# **Service Manual**

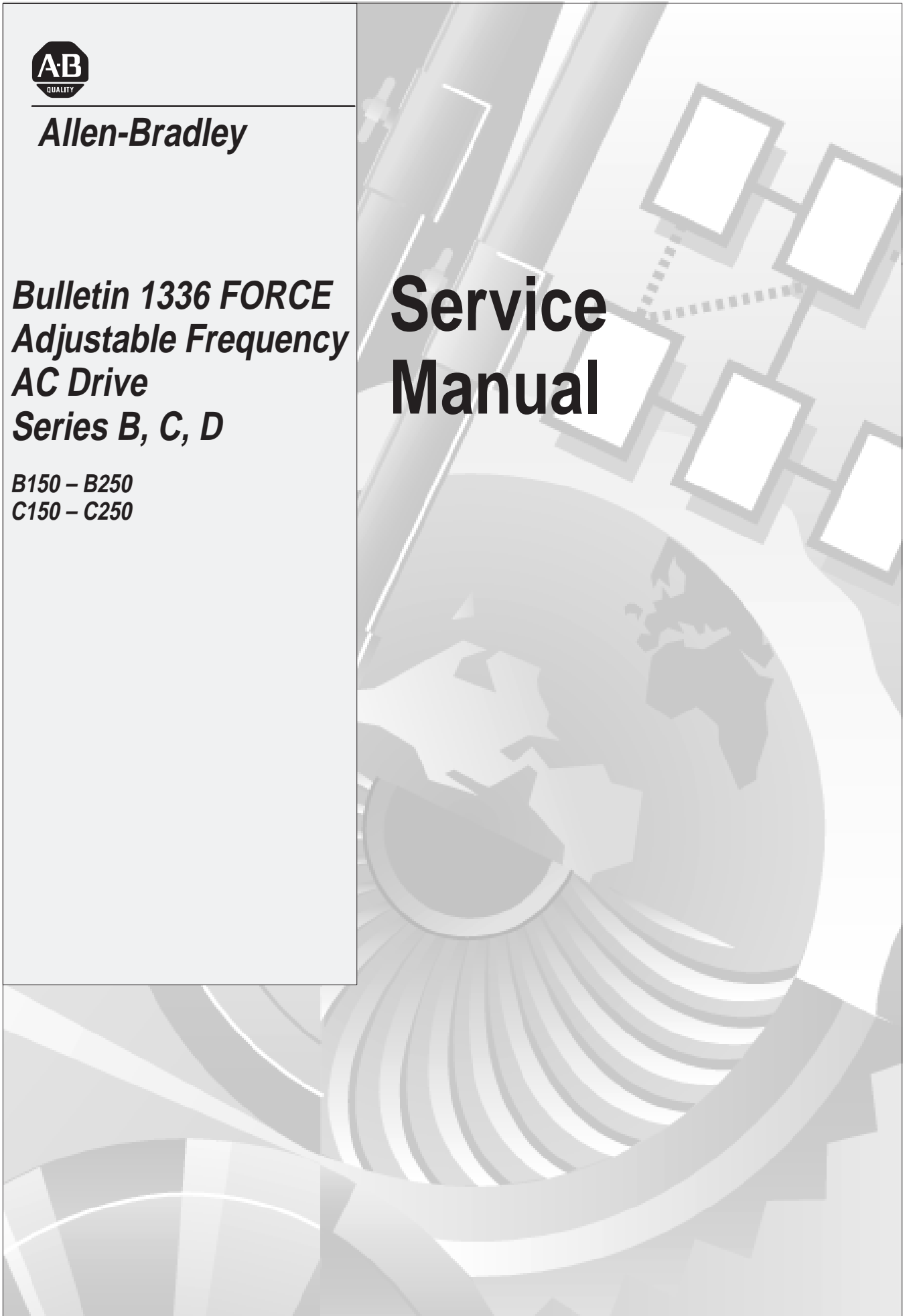

## Important User Information

Because of the variety of uses for the products described in this publication, those responsible for the application and use of this control equipment must satisfy themselves that all necessary steps have been taken to assure that each application and use meets all performance and safety requirements, including any applicable laws, regulations, codes and standards.

The illustrations, charts, sample programs and layout examples shown in this guide are intended solely for purposes of example. Since there are many variables and requirements associated with any particular installation, Allen-Bradley does not assume responsibility or liability (to include intellectual property liability) for actual use based upon the examples shown in this publication.

Allen-Bradley publication SGI-1.1, *Safety Guidelines for the Application, Installation, and Maintenance of Solid-State Control* (available from your local Allen-Bradley office), describes some important differences between solid-state equipment and electromechanical devices that should be taken into consideration when applying products such as those described in this publication.

Reproduction of the contents of this copyrighted publication, in whole or in part, without written permission of Allen-Bradley Company, Inc., is prohibited.

Throughout this manual we use notes to make you aware of safety considerations:



**ATTENTION:** Identifies information about practices or circumstances that can lead to personal injury or death, property damage or economic loss.

---

Attention statements help you to:

- identify a hazard
- avoid the hazard
- recognize the consequences

**Important:** Identifies information that is critical for successful application and understanding of the product.

# Summary of Changes

The information below summarizes the changes to the company-wide templates since the last release.

### **Updated Information**

The derating tables in the Preface have been removed. Refer to the 1336 FORCE User Manual.

**This Page Intentionally Left Blank**

## Preface

Manual Objective . . . . .	P-1
Who Should Use This Manual . . . . .	P-1
Safety Precautions . . . . .	P-1
Electrostatic Discharge Precautions . . . . .	P-2
1336 FORCE Product Identification . . . . .	P-3
Drive Nameplate Location . . . . .	P-3
Software Compatibility . . . . .	P-4
Drive and Option Identification . . . . .	P-4
1336 FORCE Drive Catalog Numbers . . . . .	P-4
Drive Rating Qualifications . . . . .	P-6
Enclosure Type . . . . .	P-6
Conventions . . . . .	P-7
Auxiliary Input . . . . .	P-7
Auxiliary Interlock . . . . .	P-7
Bit . . . . .	P-7
Check . . . . .	P-7
Connector . . . . .	P-7
Default . . . . .	P-8
Enable Input . . . . .	P-8
False . . . . .	P-8
Jumper . . . . .	P-8
Control Interface Board . . . . .	P-8
Parameter . . . . .	P-8
Press . . . . .	P-8
True . . . . .	P-9
Related Publications . . . . .	P-9

## Control Logic Wiring and Adapters

### Chapter 1

Chapter Objectives . . . . .	1-1
Chapter Overview . . . . .	1-1
Control Interface Option . . . . .	1-3
Control Interface Board Jumpers . . . . .	1-4
Available Inputs . . . . .	1-5
Standard Adapter Local Programming . . . . .	1-5
Adapters and Communication Ports . . . . .	1-11
Human Interface Module . . . . .	1-11
Standard Adapter Ports . . . . .	1-12
PLC Comm Adapter Ports . . . . .	1-12
HIM Removal . . . . .	1-13
HIM Operation . . . . .	1-14
Graphic Programming Terminal . . . . .	1-15

	GPT Description .....	1-15
	Drive Tools .....	1-16
	Control Firmware Function .....	1-16
<b>Disassembly and Access Procedures</b>	<b>Chapter 2</b>	
	Chapter Objectives .....	2-1
	Disassembly and Access Overview .....	2-1
	Electrostatic Discharge Precautions .....	2-1
	Tools .....	2-2
	Fastener Torque Specifications .....	2-3
	Torque Sequence .....	2-3
	Torque Specifications .....	2-4
	Disassembly and Access Procedures .....	2-6
	Opening the Drive Enclosure .....	2-6
	Removal .....	2-6
	Installation .....	2-7
	Removing the High Voltage Guard .....	2-8
	Removal .....	2-8
	Installation .....	2-9
	Removing Control Interface L-Option Board MOD-L4, -L5, or -L6 .....	2-10
	Removal .....	2-10
	Installation .....	2-11
	Removing the Main Control Board .....	2-12
	Removal .....	2-12
	Installation .....	2-13
	Removing the Standard Adapter Board .....	2-14
	Removal .....	2-14
	Installation .....	2-15
	Removing the PLC Comm Adapter Board .....	2-16
	Removal .....	2-16
	Installation .....	2-17
	Removing the Control Board/Adapter Mounting Plate .....	2-18
	Removal .....	2-18
	Installation .....	2-19
	Removing The Gate Driver Board Mounting Plate .....	2-20
	Removal .....	2-20
	Installation .....	2-22
	Removing the Gate Driver Board .....	2-23
	Removal .....	2-23
	Installation .....	2-24
	Removing the Precharge Board Mounting Plate .....	2-25
	Removal .....	2-25
	Installation .....	2-26
	Removing the Precharge Board .....	2-27
	Removal .....	2-27

Installation . . . . .	2-28
Removing a Power Module Snubber Board . . . . .	2-29
Removal . . . . .	2-30
Installation . . . . .	2-31
Removing an Input Rectifier Snubber Board . . . . .	2-32
Removal . . . . .	2-32
Installation . . . . .	2-33
Accessing Power Plane Components . . . . .	2-33

## Component Test Procedures

### Chapter 3

Chapter Objectives . . . . .	3-1
Component Test Overview . . . . .	3-1
Electrostatic Discharge Precautions . . . . .	3-2
Tools . . . . .	3-2
Test 1	
Testing the Gate Driver Board . . . . .	3-3
Test 2	
Testing the Precharge Board . . . . .	3-5
Test 3	
Testing the Power Modules . . . . .	3-7
Test 4	
Testing the Bus Capacitors . . . . .	3-10
Test 5	
Testing the Input Rectifiers . . . . .	3-13

## Part Replacement Procedures

### Chapter 4

Chapter Objective . . . . .	4-1
Part Replacement Overview . . . . .	4-1
Safety Precautions . . . . .	4-1
Electrostatic Discharge Precautions . . . . .	4-1
Tools . . . . .	4-2
Major Component Replacement . . . . .	4-2
Detailed Product Identification . . . . .	4-3
Bus Capacitor Bank . . . . .	4-4
Removal . . . . .	4-4
Installation . . . . .	4-6
Thermistor . . . . .	4-7
Removal . . . . .	4-7
Installation . . . . .	4-8
Power Modules . . . . .	4-9
Removal . . . . .	4-9
Installation . . . . .	4-11
Input Rectifiers . . . . .	4-12
Removal . . . . .	4-12
Installation . . . . .	4-13
Fan and Transformer Assembly . . . . .	4-14

Removal .....	4-15
Installation .....	4-17
DC Bus Inductor L1 .....	4-18
Removal .....	4-18
Installation .....	4-19
Ground Sense CT .....	4-20
Removal .....	4-20
Installation .....	4-21
Bus Fuse F1 .....	4-22
Removal .....	4-23
Installation .....	4-23
LEMs .....	4-24
Removal .....	4-24
Installation .....	4-25
MOV Surge Suppressor .....	4-26
Removal .....	4-27
Installation .....	4-27

## Replacement Parts List

### Chapter 5

Chapter Objectives .....	5-1
Ordering Replacement Parts .....	5-1
Replacement Parts Listing .....	5-2

## Schematics — 150 – 300 HP 1336 FORCE Drives

### Chapter 6

## Glossary

## Index

## Notes



## **Preface**

### **Manual Objective**

The information in this manual is designed to help repair an Allen-Bradley Bulletin 1336 FORCE Adjustable Frequency AC Drive with ratings B150 – B250, C150 – C250, and CX300.

### **Who Should Use This Manual**

This manual is intended for qualified service personnel responsible for repairing the 1336 FORCE Adjustable Frequency AC Drive. You should:

- Read this entire manual before performing maintenance or repairs to drives.
- Have previous experience with, and basic understanding of, electrical terminology, procedures, required equipment, equipment protection procedures and methods, and safety precautions.

This manual describes equipment and disassembly procedures. You begin with general illustrations and end with greater detail concerning replacement parts and part locations on the drives. Later chapters may refer you back to earlier chapters for information on basic equipment and steps necessary to perform detailed diagnostics and part replacement.

### **Safety Precautions**



**ATTENTION:** Some printed circuit boards and drive components may contain hazardous voltage levels. Remove and lock out power before you disconnect or reconnect wires, and before you remove or replace fuses and circuit boards. Verify bus voltage by measuring the voltage between +DC and –DC on Terminal Block TB1. Do not attempt to service the drive until the bus voltage has discharged to zero volts.

---



**ATTENTION:** Potentially fatal voltages may result from improper usage of oscilloscope and other test equipment. The oscilloscope chassis may be at a potentially fatal voltage if not properly grounded. If an oscilloscope is used to measure high voltage waveforms, use only a dual channel oscilloscope in the differential mode with X 100 probes. It is recommended that the oscilloscope be used in the A minus B Quasi-differential mode with the oscilloscope chassis correctly grounded to an earth ground.

---



**ATTENTION:** Only personnel familiar with the 1336 FORCE Adjustable Frequency AC Drive and associated machinery should plan or implement the installation, start-up and subsequent maintenance of the system. Failure to comply may result in personal injury and/or equipment damage.

---

## Electrostatic Discharge Precautions



**ATTENTION:** This assembly contains parts and sub-assemblies that are sensitive to electrostatic discharge. Static control precautions are required when servicing this assembly. Component damage may result if you ignore electrostatic discharge control procedures. If you are not familiar with static control procedures, reference Allen-Bradley Publication 8000-4.5.2, Guarding Against Electrostatic Damage, or any other applicable ESD protection handbook.

---

Electrostatic discharge generated by static electricity can damage the complimentary metallic oxide semiconductor devices on various drive boards. It is recommended that you perform these procedures to guard against this type of damage when circuit boards are removed or installed:

- Wear a wrist-type grounding strap that is grounded to the drive chassis.
- Attach the wrist strap before removing the new circuit board from the conductive packet.
- Remove boards from the drive and immediately insert them into their conductive packets.

## 1336 FORCE Product Identification

### Drive Nameplate Location

The drive nameplate is located on the face of the Main Control Board Mounting Plate. The drive nameplate contains the drive's catalog number and other important drive information. Reference the catalog number when ordering replacement parts.

**Figure P.1**  
Drive Nameplate Location

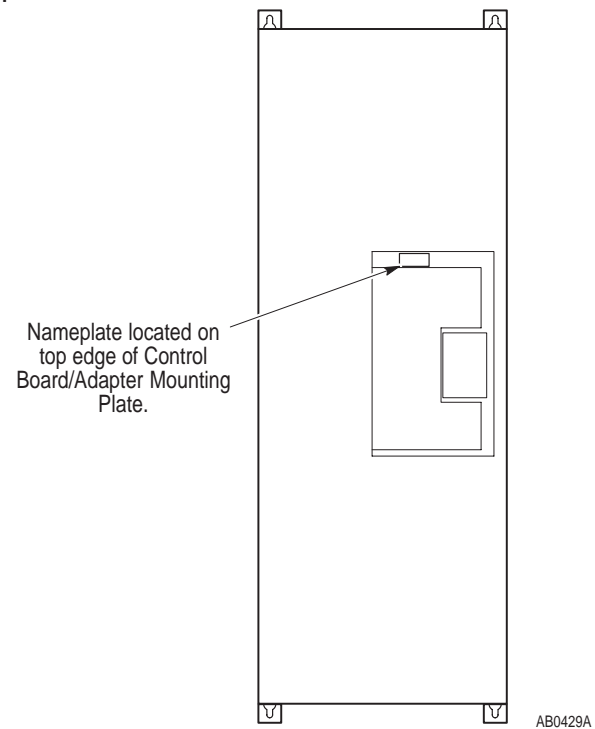

## Software Compatibility



**ATTENTION:** To guard against machine damage and/or personal injury, drives with ratings above 45 kW (60 HP) must not be used with software versions below 1.07. Refer to the table below.

Three-Phase Drive Rating <sup>[1]</sup>			
380 – 480V	500 – 600V	Compatible with Version	Frame Reference
112 – 187 kW 150 – 250 HP	112 – 224 kW 150 – 300 HP	2.01 & Up	E

<sup>[1]</sup> kW and HP are constant torque (CT) ratings.

## Drive and Option Identification

The following is an explanation of the catalog numbering system for 1336 FORCE Adjustable Frequency AC Drives and options. The catalog number is coded to identify the drive power rating and can be found on the drive shipping carton and nameplate.

### 1336 FORCE Drive Catalog Numbers

Table P.A

1336T	– B150-AA	– GT2EN	– L6	– HA1	– GM1
BULLETIN NO.	RATING-ENCLOSURE (MUST BE SPECIFIED)	LANGUAGE MODULE <sup>[3]</sup> (MUST BE SPECIFIED)	CONTROL INTERFACE <sup>[3]</sup> (OPTIONAL)	HUMAN INTERFACE <sup>[3]</sup> (OPTIONAL)	COMMUNICATION CARD <sup>[3]</sup> (OPTIONAL)

#### 380 – 480V AC Input, Constant or Variable Torque Drive

Drive Rating <sup>[1]</sup>			Enclosures			
			Open IP00 No Enclosure	NEMA Type 1 IP20 General Purpose	NEMA Type 4 IP56 Resist Water, Dust	NEMA Type 12 IP54 Industrial Use
Frame Designation	Constant Torque		Code	Code	Code	Code
	Output Amps	Nominal HP				
E	240.0 291.4 327.4	150 200 250	B150-AN B200-AN B250-AN	B150-AA B200-AA B250-AA	<sup>[2]</sup> <sup>[2]</sup> <sup>[2]</sup>	B150C-AJ B200C-AJ B250C-AJ

Table P.B

1336T	- C200-AA	- GT2EN	- L6	- HA1	- GM1
<b>BULLETIN NO.</b>	<b>RATING-ENCLOSURE (MUST BE SPECIFIED)</b>	<b>LANGUAGE MODULE<sup>③</sup> (MUST BE SPECIFIED)</b>	<b>CONTROL INTERFACE<sup>③</sup> (OPTIONAL)</b>	<b>HUMAN INTERFACE<sup>③</sup> (OPTIONAL)</b>	<b>COMMUNICATION CARD<sup>③</sup> (OPTIONAL)</b>

## 500 – 600V AC Input, Constant or Variable Torque Drive

Drive Rating <sup>①</sup>		Enclosures				
		Open IP00 No Enclosure	NEMA Type 1 IP20 General Purpose	NEMA Type 4 IP56 Resist Water, Dust	NEMA Type 12 IP54 Industrial Use	
Frame Designation	Constant Torque					
E	Output Amps	Nominal HP CT	Code	Code	Code	Code
	159.7 228.6	150 200	C150-AN C200-AN	C150-AA C200-AA	<sup>②</sup> <sup>②</sup>	C150C-AJ C200C-AJ
	284.0	250	C250-AN	C250-AA	<sup>②</sup>	C250C-AJ
	300.0	300	CX300-AN	CX300-AA	<sup>②</sup>	CX300-AJ

<sup>①</sup> Drive rating is based on a carrier frequency of 2kHz maximum, an altitude of 1,000 meters or less, and a maximum ambient temperature of 40°C. Refer to Qualifications on page P-6.

<sup>②</sup> Not available.

<sup>③</sup> Refer to the Language Module and Options tables following these Catalog Number tables.

Table P.C

Language Modules	
Description	Option Code
English/English	EN
English/French	FR
English/German	DE
English/Italian	IT
English/Japanese	JP
English/Spanish	ES

Table P.D

		Options	
Code <sup>[2]</sup>	Description <sup>[1]</sup>	Code	Description <sup>[1]</sup>
Human Interface Modules, NEMA Type 1 (IP20)		Communication Options	
HAB	Blank – No Functionality	GT1E	PLC Communication
HAP	Programmer Only	N	Adapter, English
HA1	Programmer/Controller with Analog Pot		Standard Adapter,
HA2	Programmer/Controller with Digital Pot	GT2E	English
		N	No Adapter
		GT0	
Human Interface Modules, NEMA Type 4 (IP56)		Control Interface Options	
HFP	Programmer Only	L4	Contact Closure
HF2	Programmer/Controller with Digital Pot	L5	+24V AC/DC
		L6	115V AC
Human Interface Modules, NEMA Type 12 (IP54)			
HJP	Programmer Only		
HA2	Programmer/Controller with Digital Pot		

<sup>[1]</sup> For a more functionally complete description of each option refer to Publication 1336 FORCE-1.0

<sup>[2]</sup> Must be used in conjunction with a standard adapter option –GT2EN.

## Drive Rating Qualifications

Several factors can affect drive rating. If more than one factor exists, derating percentages must be multiplied. For example, if a 14-amp drive is installed at a 2km (6,600 ft.) altitude and has a 2% high-input line voltage, the actual amp rating is: 14 x 94% altitude derating x 96% high-input line derating = 12.6 amps

## Enclosure Type

The first character, A, indicates the Enclosure Code.

The second character indicates the type of enclosure shipped from the factory:

Table P.E  
Enclosure Type Code Description

Enclosure Type Code	Description
N	Open style (IP00)
A	NEMA Type 1 (IP20)
F	NEMA Type 4 (IP56)
J	NEMA Type 12 (IP54)

## Conventions

To help differentiate parameter names and display text from other text in this manual, the following conventions will be used:

- Parameter Names will appear in [brackets].
- Display Text will appear in “quotes”.

The following is a list of conventions used throughout this manual, and definitions of the conventions. For a list of terminology and definitions, refer to the Glossary in the back of this manual.

### Auxiliary Input

The Auxiliary Input is a terminal connection on the Control Interface Board. This connection provides an external input for use as an Auxiliary Interlock. Unless this interlock is closed, the drive will be faulted with an Auxiliary Fault.

### Auxiliary Interlock

The Auxiliary Interlock is a user supplied circuit consisting of reset, overload, or other interlocking circuitry. The Interlock is wired to the drive Auxiliary input.

### Bit

A bit is a single character or status point used in programmable logic. Eight bits form a BYTE, 16 bits form a word. Drive parameters are actually eight-bit or 16-bit words.

### Check

To check means to examine either the physical condition of something or the setting of some control, such as a Parameter. Checking a drive board or component may also require measurements and tests.

### Connector

A connector connects one drive board to another. Connectors come in two designs, male and female. Male connectors are stationary and contain pins, which are sometimes joined by jumpers. Female connectors are at the ends of wires or ribbon cables and plug into male connectors.

### **Default**

When a drive function defaults, it automatically changes to a pre-programmed setting.

### **Enable Input**

The Enable Input is a terminal connection on the Control Interface Board. This connection provides an external input to enable or disable the Drive Output section. It must be a logic “true” to permit the drive to operate.

### **False**

False refers to a logical false state. For instance, a Control Interface signal on TB3 is false when the input contact is open or the appropriate voltage is not applied to the Control Interface Board.

### **Jumper**

A jumper completes a circuit between two pins within a male connector on a drive board. In the absence of certain optional equipment using female connectors, jumpers are applied to certain pins within a male connector to complete specific and necessary circuits.

### **Control Interface Board**

A Control Interface Board plugs into connectors J7 and J9, located on the lower portion of the Standard Adapter Board. This board is identified as L4, L5 or L6 and provides optional control wiring configurations for a drive.

### **Parameter**

Parameters are programmable drive functions that define various operating functions or status displays of a drive. Refer to Bulletin 1336 FORCE Adjustable Frequency AC Drive User Manual for Parameter details.

### **Press**

Press a button on the Human Interface Module to change Parameter settings and drive functions.



## True

True refers to a logical true state. For instance, a Control Interface signal on TB3 is true when: L4 contact input is closed, L5 input terminal registers 24V, or L6 input terminal registers 115V AC.

## Related Publications

The following lists other Allen-Bradley publications that apply to the 1336 FORCE Adjustable Frequency AC Drives:

- Product Data Drive Tools Software (9303-2.0)
- Bulletin 1201 Graphic Programming Terminal User Manual (1201-5.0)
- Product Pricing Bulletin (1336 FORCE-3.0)
- 1336 FORCE Field Oriented Control User Manual (1336 FORCE-5.12)
- 1336 FORCE PLC Communications Adapter User Manual (1336 FORCE-5.13)
- Renewal Parts List (1336 FORCE-6.0)
- Options Manuals/Instructions

**This Page Intentionally Left Blank**

## Control Logic Wiring and Adapters

### Chapter Objectives

This chapter introduces you to terminal block locations and wiring, and adapter locations and functions.

### Chapter Overview

This chapter illustrates and describes Standard Adapter Board:

- Control Logic Interface Options L4, L5, and L6, including terminal block TB3
- TB3 input mode selections and functions
- TB3, TB5, TB6, TB7 terminal designations

This chapter illustrates and describes the following terminal designations for the PLC Comm Adapter Board:

- TB20
- TB21

**Important:** All printed circuit boards, except the Main Control Board assembly, are referenced to negative ground (–bus).



**ATTENTION:** Some printed circuit boards and drive components may contain hazardous voltage levels. Remove power before you disconnect or reconnect wires, and before you remove or replace fuses and circuit boards. Verify bus voltage by measuring the voltage between +DC and –DC on Terminal Block TB1. Do not attempt to service the drive until the bus voltage has discharged to zero volts.



**ATTENTION:** This assembly contains parts and sub-assemblies that are sensitive to electrostatic discharge. Static control precautions are required when servicing this assembly. Component damage may result if you ignore electrostatic discharge control procedures. If you are not familiar with static control procedures, reference Allen-Bradley Publication 8000–4.5.2, Guarding Against Electrostatic Discharge, or any other applicable ESD protection handbook.

---

**Figure 1.1**  
Standard Adapter Terminal Block Locations

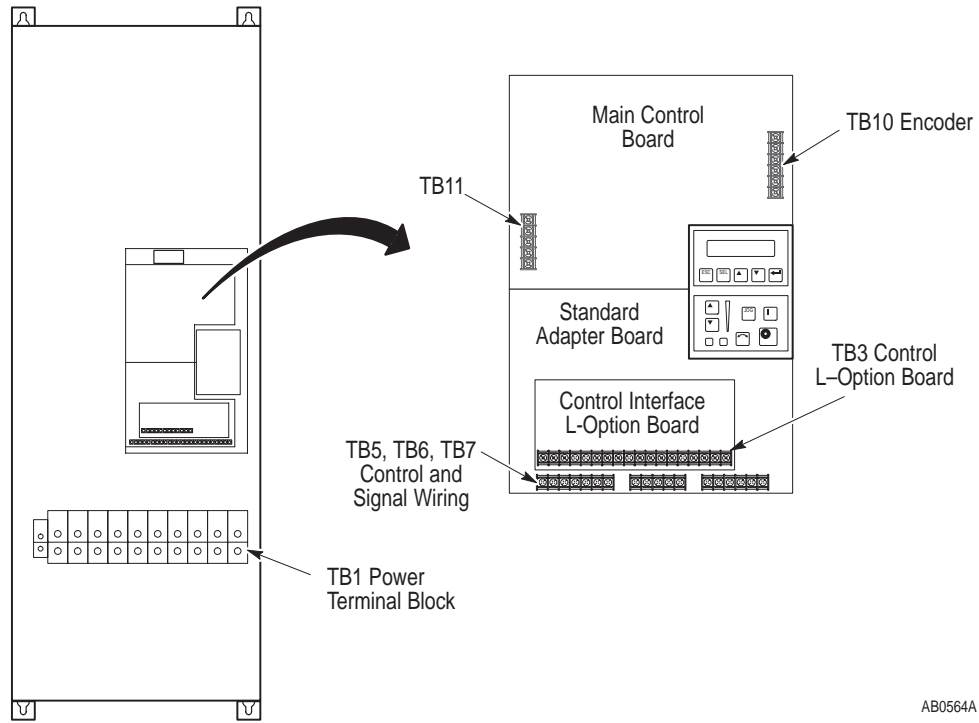

**Figure 1.2**  
PLC Comm Adapter Terminal Block Locations

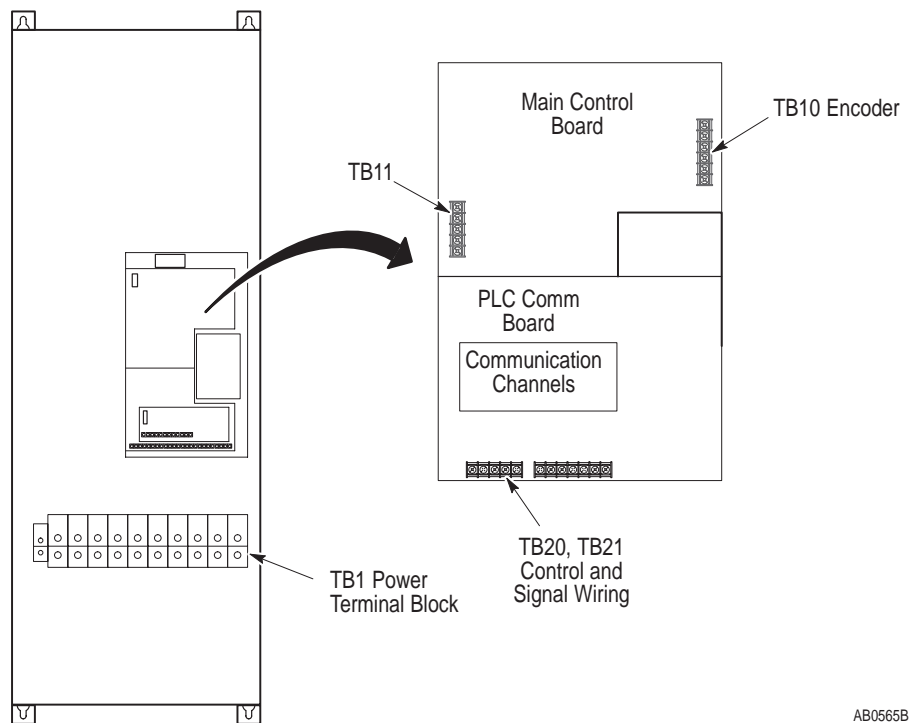



**ATTENTION:** The National Electrical Code (NEC) and local codes outline provisions for safely installing electrical equipment. Installation must comply with specifications regarding wire types, conductor sizes, branch circuit protection and disconnect devices. Failure to do so may result in personal injury and/or equipment damage.

---

## Control Interface Option

The Control Interface L-Option Board provides a means of interfacing various signals and commands to the 1336 FORCE by using contact closures.

Three different versions of the option are available:

- L4 Contact Closure Interface<sup>1</sup>
- L5 +24V AC/DC Interface
- L6 115V AC Interface

<sup>1</sup> Uses internal +5V DC supply.

The user inputs are connected to the option board through TB3. The L4, L5 and L6 options each have nine control inputs. The function of each input must be selected through programming as explained later in this section.

## Control Interface Board Jumpers

**Important:** If the Control Interface Board is being installed, Standard Adapter Board jumpers at pins 3 & 4 and 17 & 18 of J10 must be removed. If this board is removed, these jumpers must be reinstalled and the [Input Mode] parameter must be programmed to “1”.

**Figure 1.3**  
Jumper Locations

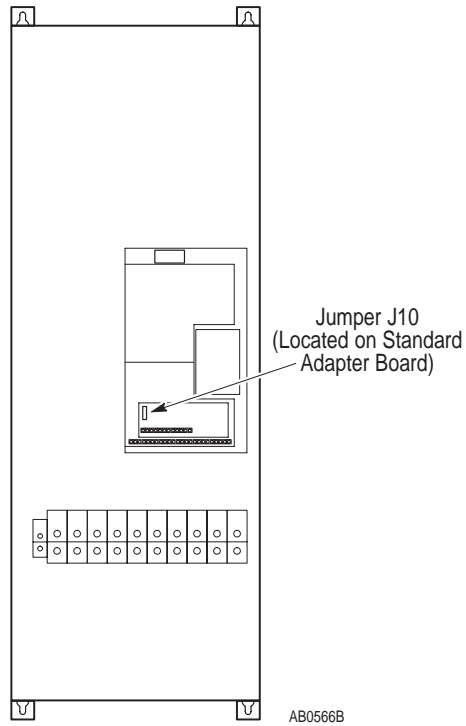

## Available Inputs

A variety of combinations made up of the following inputs are available.

Start	Enable
Stop/Clear Fault	Auxiliary
Reverse	2 Stop Mode Selects
Digital Potentiometer (MOP)	Run Forward
2 Accel/Decel Rates	Run Reverse
3 Speed Selects	Local Control

The available combinations are shown in Figure 1.4. Programming the [Input Mode] parameter to one of the Input Mode numbers listed selects that combination of input functions.

**Important:** The [Input Mode] parameter can be changed at any time; however, programming changes will not take affect until power has been cycled to the drive. When changing an input mode, it is important to note that the corresponding inputs to TB3 may also change.

The programming options of the Control Interface Option allow the user to select an input combination to meet the needs of a specific installation. Appropriate selection of a combination may be done by using Table 1.A. First determine the type of start/stop/direction control desired. Then select the remaining control functions available. After selecting a group of Input Modes use Table 1.A for specific mode selection. Record the selected mode number below.

Selected Mode Number: \_\_\_\_\_

## Standard Adapter Local Programming

For local programming and control information, refer to the 1336 FORCE User Manual.

**Table 1.A**  
**Input Mode Selection**

Start/Stop Type	Direction Control	Communication Compatibility	Mode(s) to Use
Stop & Enable Only	None	Control must be provided by HIM or Communication Option.	1
Momentary Pushbutton (3 Wire)	Maintained Switch (Open-Forward, Closed-Reverse)	Start/Stop – works in parallel with HIM and Communication Options. Direction Control will not work in parallel with HIM or Communication Options. User must select direction control from either HIM and Communication Options or TB3 input.	2 – 6
Momentary Pushbutton (3 Wire)	Momentary Pushbuttons (Forward and Reverse)	Start/Stop – works in parallel with HIM and Communication Options. Direction – works in parallel with HIM or Communication Options.	7 – 11
Maintained switches for combined run and direction control (2 wire, Run Forward, Run Reverse)		Start/Stop – not compatible with HIM or Communication Options. Direction – not compatible with HIM or Communication Options.	12 – 16

The maximum and minimum wire sizes accepted by TB3 is 2.1 and 0.30 mm<sup>2</sup> (14 and 22 AWG). Maximum torque for all terminals is 0.9 – 1.13 N-m (8 – 10 lb-in.).

**Figure 1.4**  
**TB3 Terminal Designations**

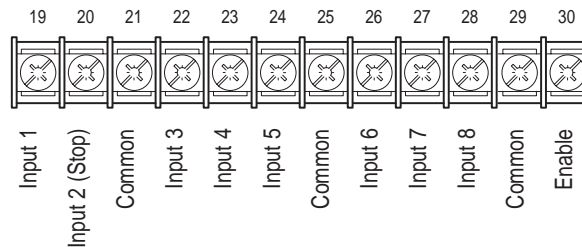

AB0550A



**Figure 1.5**  
Input Mode Selection and Typical TB3 Connections

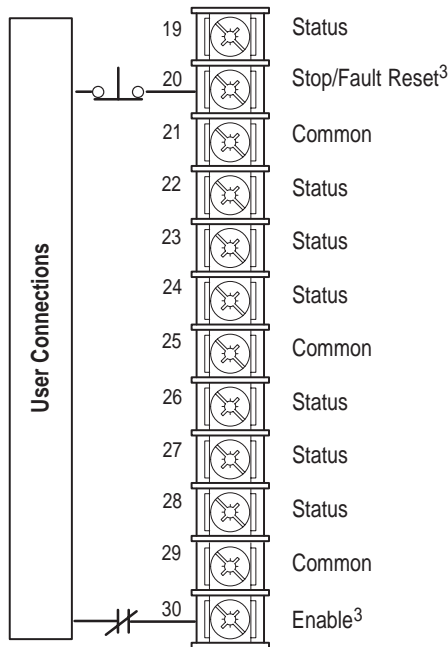
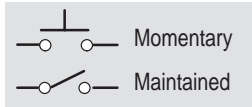

**[Input Mode] 1**  
**Factory Default**

Note: If this mode is selected, the status of all inputs can be read at the [Input Status] parameter. However, only "Stop/Fault Reset" and "Enable" will have control function.

**[Input Mode] 2 – 6**  
**Three-Wire Control with Single-Source Reversing**

**ATTENTION:** The JOG function will not operate properly unless a SCANport option is connected to the drive. To assure proper JOG function, install at least one of the following:  
1201-HAP, 1201-HA1, 1201-HA2, 1336-GM1. Applies to 1305 with firmware FRN 2.01 or earlier and 1336 PLUS with Language Module 1336S-EN firmware FRN 1.05 or earlier.

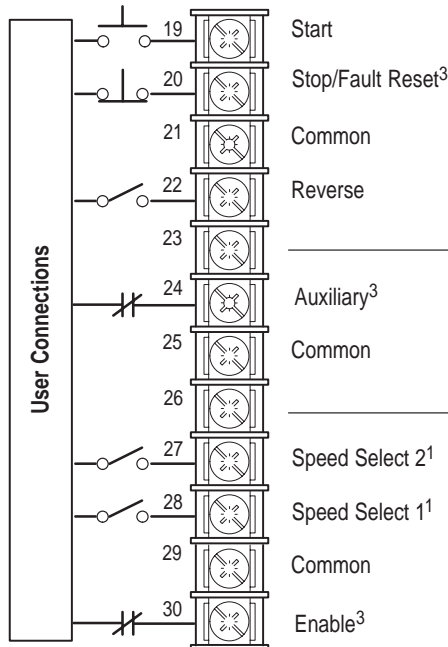

	Mode				
	2	3	4	5	6
	Jog	Stop Type	2nd Accel	Digital Pot Up	Jog
	Speed Select 3 <sup>1</sup>	Speed Select 3 <sup>1</sup>	2nd Decel	Digital Pot Dn	Local Control <sup>2</sup>

1 See Table 1.B.  
2 Drive must be stopped to take Local Control. Control by all other adapters is disabled (except Stop).  
3 These inputs must be present before drive will start.

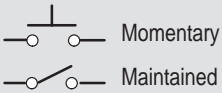

**ATTENTION:** The JOG function will not operate properly unless a SCANport option is connected to the drive. To assure proper JOG function, install at least one of the following:  
 1201-HAP, 1201-HA1, 1201-HA2, 1336-GM1. Applies to 1.305 with firmware FRN 2.01 or earlier and 1.336 PLUS with Language Module 1336S-EN firmware FRN 1.05 or earlier.

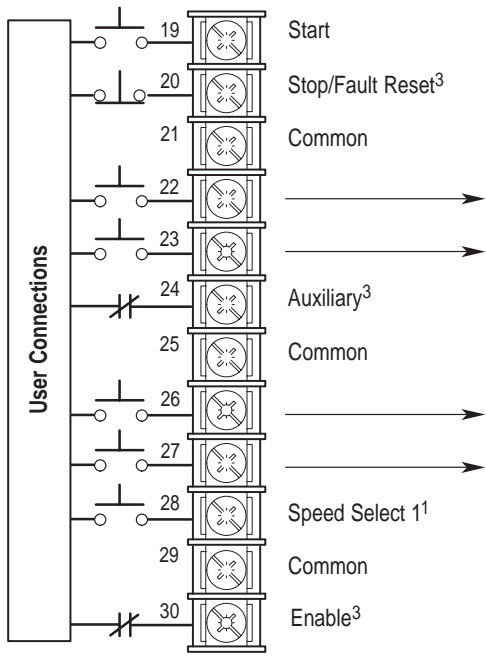

**[Input Mode] 7 – 11**  
**Three-Wire Control with Multi-Source Reversing**

	Mode				
	7	8	9	10	11
Reverse	Reverse	Reverse	Digital Pot Up	Reverse	1st Accel
Forward	Forward	Forward	Digital Pot Dn	Forward	2nd Accel
Jog		Speed Select 3 <sup>1</sup>	Speed Select 3 <sup>1</sup>	Digital Pot Up	1st Decel
Speed Select 2 <sup>1</sup>	Speed Select 2 <sup>1</sup>	Speed Select 2 <sup>1</sup>	Speed Select 2 <sup>1</sup>	Digital Pot Dn	2nd Decel

**[Input Mode] 12 – 16**  
**Two-Wire Control, Single-Source Control**

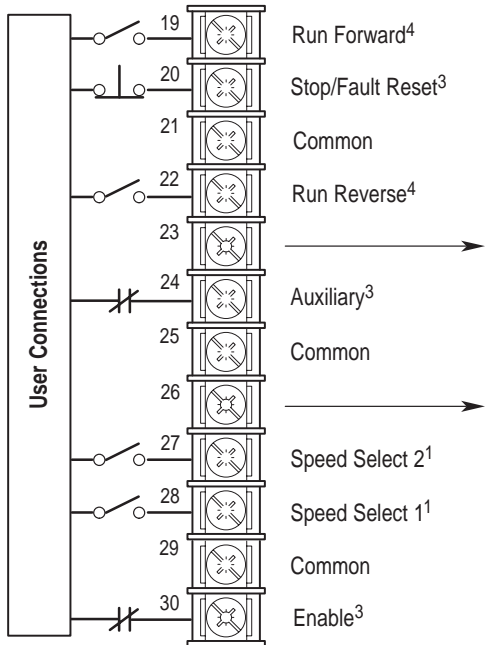

	Mode				
	12	13	14	15	16
Local Control <sup>2</sup>	Local Control <sup>2</sup>	Stop Type	2nd Accel	Digital Pot Up	Local Control <sup>2</sup>
Speed Select 3 <sup>1</sup>	Speed Select 3 <sup>1</sup>	Speed Select 3 <sup>1</sup>	2nd Decel	Digital Pot Dn	Stop Type

1 See Table 1.B.  
 2 Drive must be stopped to take Local Control. Control by all other adapters is disabled (except Stop).  
 3 These inputs must be present before drive will start.

The following table defines the input state of the Speed Select inputs for a desired frequency source.

**Table 1.B**  
Speed Select Input State vs. Velocity Reference Source

Para 52 TB3	Speed Select 3 Bit 14 Terminal 26	Speed Select 2 Bit 13 Terminal 27	Speed Select 1 B12 Terminal 28	Velocity Reference Source
	O	O	O	Last State
	O	O	X	External Reference 1
	O	X	O	Preset Speed 1
	O	X	X	Preset Speed 2
	X	O	O	Preset Speed 3
	X	O	X	Preset Speed 4
	X	X	O	Preset Speed 5
	X	X	X	External Reference 2

O = Open — Input Removed

X = Closed — Input Present

The DIP switches and jumpers on the PLC Communications Board have been preset at the factory. Communication is received through Channels A and B. This communication protocol is defined through SW U2 – U5. If switches or jumpers require reconfiguration, refer to the 1336 FORCE PLC Communications Adapter User Manual.

**Figure 1.6**  
PLC Comm Adapter Reference Signal Connections

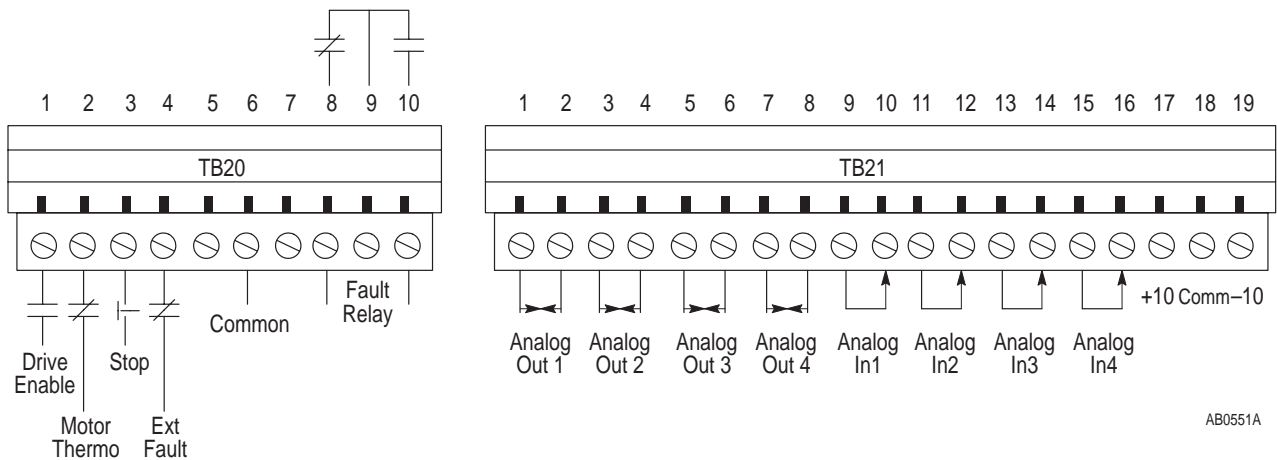

AB0551A

**Table 1.C**  
**PLC Comm Adapter Reference Signal Connections**

Terminal Block	Terminal Number(s)	Signal
TB20	1	Drive Enable (NO)
	2	Motor Thermoguard (NC)
	3	Normal Stop (NC)
	4	External Fault (NC)
	5	
	6	Input Common
	7	
	8	Fault Output (NC)
	9	Fault Output (COM)
	10	Fault Output (NO)
TB21	1	OUT 1
	2	COM 1
	3	COM 2
	4	OUT 2
	5	OUT 3
	6	COM 3
	7	OUT 4
	8	COM 4
	9	IN 1+
	10	IN 1-
	11	IN 2+
	12	IN 2-
	13	IN 3+
	14	IN 3-
	15	IN 4+
	16	IN 4-
	17	+10V
	18	COM
	19	-10V

## Adapters and Communication Ports

### Human Interface Module

When the drive-mounted HIM is supplied, it will be connected as Port 1 (refer to Figure 1.8) and visible from the front of the drive. The HIM can be divided into two sections; Display Panel and Control Panel. The Display Panel provides a means of programming the drive and viewing the various operating parameters. The Control Panel allows different drive functions to be controlled. Refer to the 1336 FORCE User Manual for HIM operation.

**Important:** The operation of HIM functions depends upon drive parameter settings. Default parameter values allow full HIM functionality.

**Figure 1.7**  
Human Interface Module, Standard Adapter Only

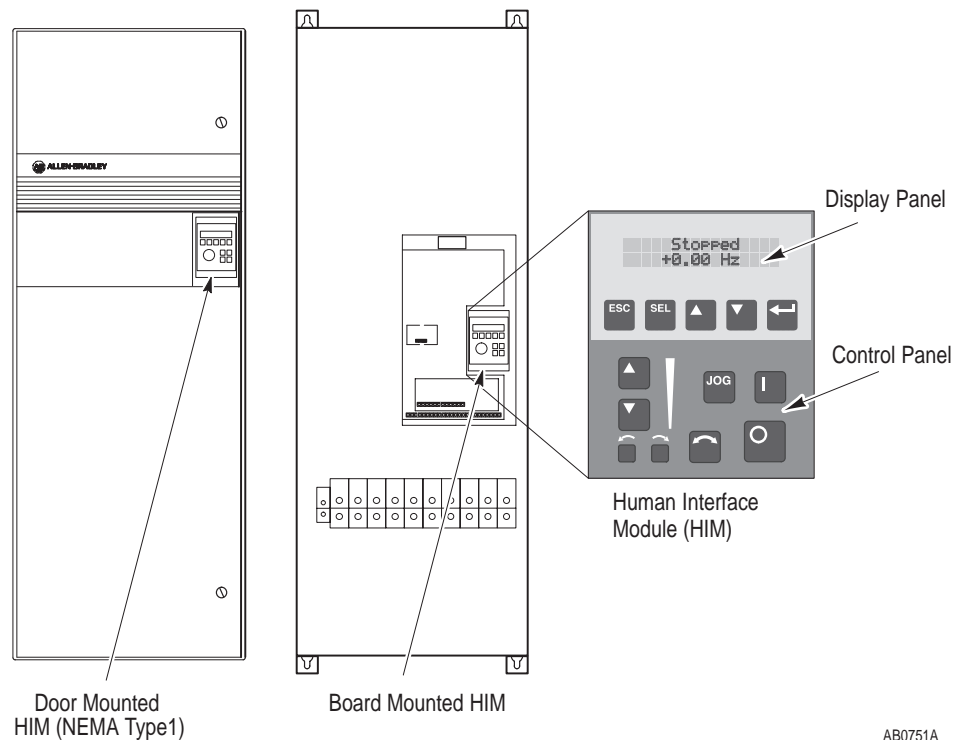

AB0751A

### Standard Adapter Ports

Figure 1.8  
Standard Adapter Board Port Locations

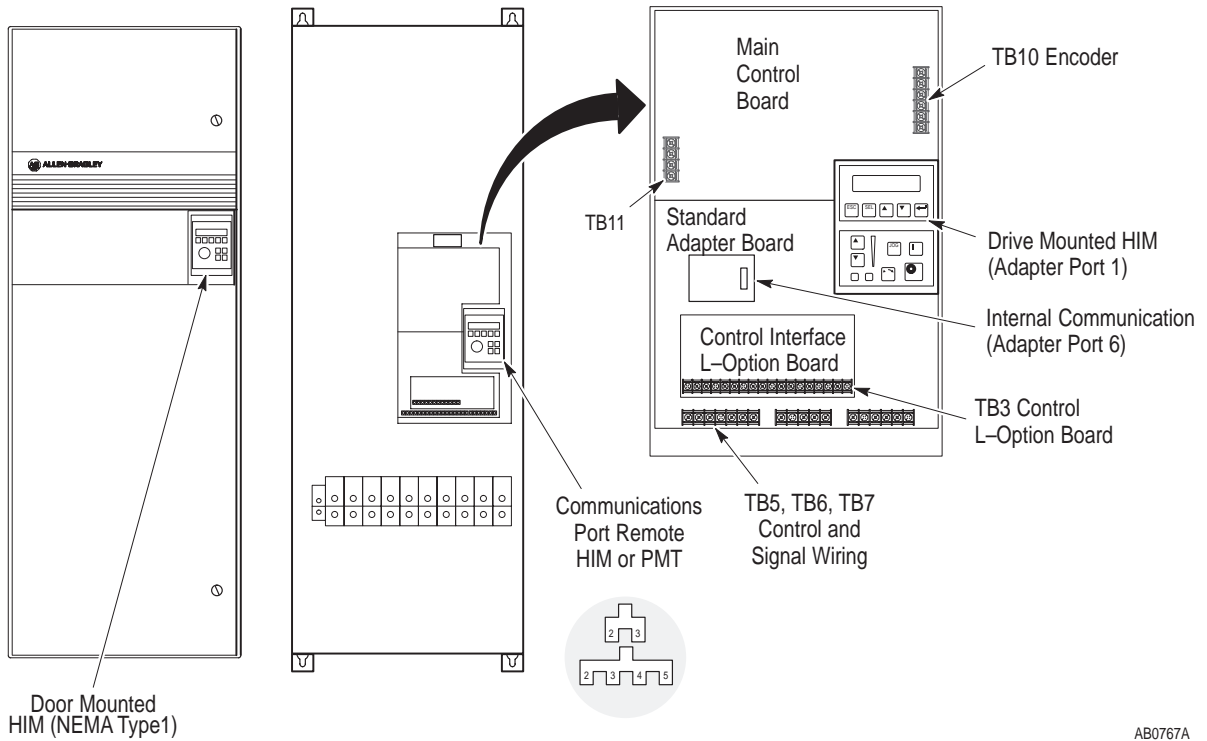

AB0767A

### PLC Comm Adapter Ports

Figure 1.9  
PLC Comm Adapter Board Port Locations

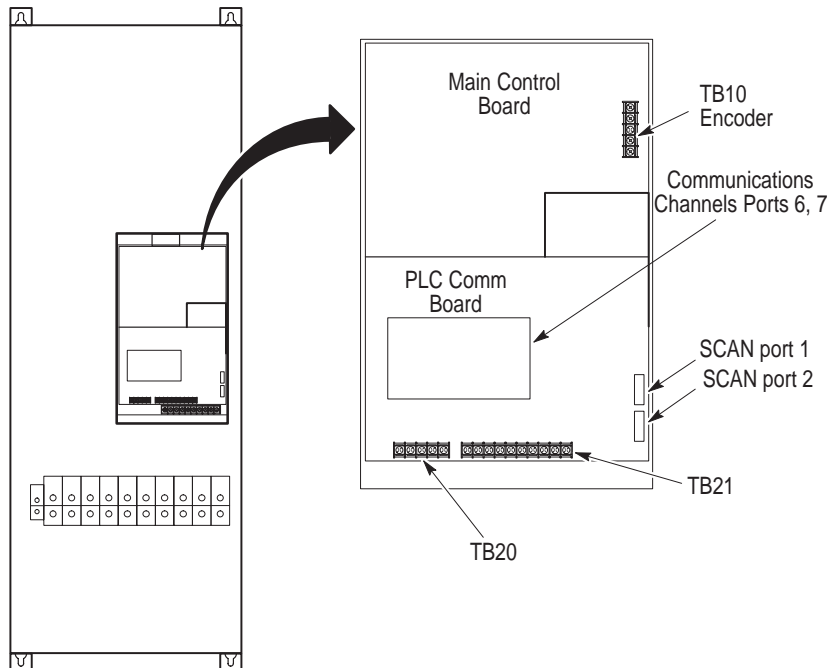

AB0768A

---

## HIM Removal

---



**ATTENTION:** Some voltages present behind the drive front cover are at incoming line potential. To avoid an electric shock hazard, use extreme caution when removing/replacing the HIM.

---

For handheld operation, the module can be removed and located up to 10 meters (33 feet) from the drive.

**Important:** Power must be removed from the drive or Bit 1 of the [Logic Mask] parameter must be set to “0” to allow removal of the HIM module without causing a Communication Fault. Setting Bit 1 of the [Logic Mask] parameter to “0” allows HIM removal while power is applied to the drive. Note that this also disables all HIM control functions except Stop.

To remove the module:

1. Ensure that power has been removed or [Logic Mask] has been set to “0”.
2. Take the drive front cover off and simply slide the module down and out of its cradle. Remove cable from module.
3. Connect the appropriate cable between the HIM and the Communications Port (Adapter 2, 3, 4, or 5).
4. Reverse the above steps to replace the module. Apply power or reset Bit 1 of the [Logic Mask] parameter to “1” to enable HIM control.

## HIM Operation

When power is first applied to the drive, the HIM will cycle through a series of displays. These displays will show drive ID and communication status. Upon completion, the Status Display (refer to Figure 1.10) will be shown. This display shows the current status of the drive (i.e. Stopped, Running, etc.) or any faults that may be present (Not Enabled, etc.).

Refer to the 1336 FORCE Field Oriented Control User Manual for HIM operation.

**Figure 1.10**  
**Status Display**

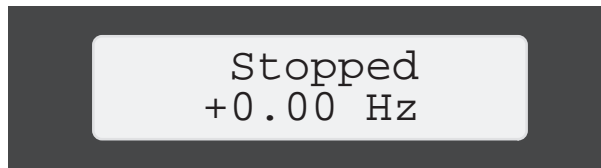



## Graphic Programming Terminal

### GPT Description

The optional GPT (Figure 1.11) is a remote device with a 1.8 meter (6 foot) long cable. The GPT offers a 40- by 8-character display that can also be used as a graphics display to show trending graphs. For GPT operation, refer to the 1336 FORCE Field Oriented Control User Manual. See also the 1201 GPT User Manual.

**Important:** Main Menu screens are dynamic and will change based on functionality provided by adapter and drive status.

**Figure 1.11**  
Graphic Programming Terminal

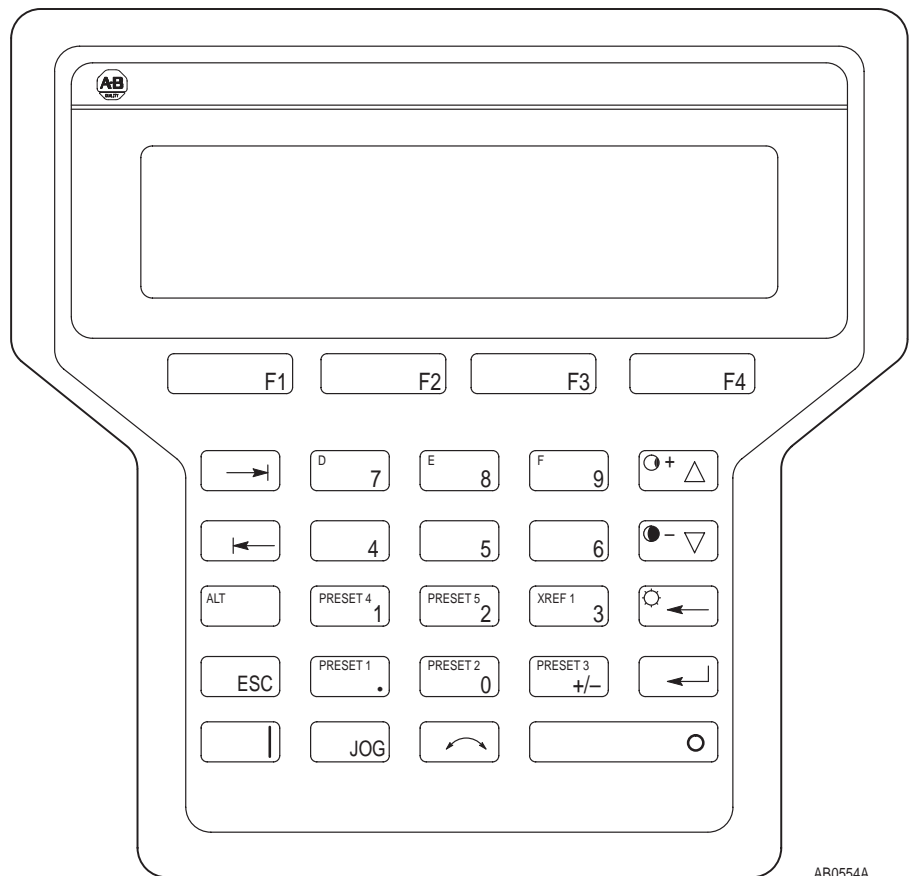

AB0554A

## Drive Tools

Drive Tools software is a Windows 3.1 compatible family of application programs allowing the user to perform programming, monitoring, and diagnostic operations on Allen-Bradley AC and DC digital drive products. The software consists of five Windows applications. For operation, refer to the Product Data Drive Tools Software manual.

## Control Firmware Function

All control functions in the 1336 FORCE are performed through the use of parameters that can be changed with a programming terminal or Drive Tools. Refer to an overview Block Diagram of the Control Firmware Function in the 1336 FORCE Field Oriented Control User Manual.

Feedback information is derived from hardware devices as part of the process equipment used. Analog signals are converted to digital signals for use by the drive. Control signals may be provided to the drive by one of two Adapter Boards.

All setup and operation information used by the drive is stored in a system parameter table. Every parameter, including Setup and Configuration parameters (Sources and Sinks), has an entry in the parameter table. For example, parameter 101 is named the “Velocity Reference 1 HI (whole)” parameter and contains a number value representing the velocity reference. The velocity reference can originate from an external control device such as a potentiometer connected to the analog input of an Adapter board or a signal coming in via RIO from a PLC. Refer to the 1336 FORCE User Manual, Publication 1336 FORCE-5.12.

## Disassembly and Access Procedures

### Chapter Objectives

This chapter describes general disassembly procedures required to access internal drive components.

### Disassembly and Access Overview



**ATTENTION:** Some printed circuit boards and drive components may contain hazardous voltage levels. Remove and lock out power before you disconnect or reconnect wires, and before you remove or replace fuses and circuit boards. Verify bus voltage by measuring the voltage between +DC and –DC on Terminal Block TB1. Do not attempt to service the drive until the bus voltage has discharged to zero volts.

---



**ATTENTION:** Servicing energized industrial control equipment can be hazardous. Electrical shock, burns, or unintentional actuation of controlled industrial equipment may cause death or serious injury. Follow the safety-related practices of NFPA 70E, Electrical Safety for Employee Workplaces, when working on or near energized equipment. Do not work alone on energized equipment.

---

### Electrostatic Discharge Precautions



**ATTENTION:** This assembly contains parts and sub-assemblies that are sensitive to electrostatic discharge. Static control precautions are required when servicing this assembly. Component damage may result if you ignore electrostatic discharge control procedures. If you are not familiar with static control procedures, reference Allen-Bradley Publication 8000–4.5.2, Guarding Against Electrostatic Discharge, or any other applicable ESD protection handbook.

---

Electrostatic discharge generated by static electricity can damage the complimentary metallic oxide semiconductor devices on various drive boards. It is recommended that you perform these procedures to guard against this type of damage when circuit boards are removed or installed:

- Wear a wrist-type grounding strap that is grounded to the chassis.
- Attach the wrist strap before removing the new circuit board from the conductive packet.
- Remove boards from the drive and immediately insert them into their conductive packets.

### **Tools**

You need the following tools to disassemble and assemble the drive:

- Pliers
- Phillips screwdrivers (small, medium, and large)
- Standard screwdrivers (small, medium, and large)
- 25/64-inch or 10 mm socket
- 7/16-inch or 11 mm socket
- 33/64-inch or 13 mm deep-well socket
- 5/16-inch or 8 mm open-end wrench
- Torque wrench, metered in lb-in. or N-m
- Nylon tie wraps

## Fastener Torque Specifications

### Torque Sequence

When mounting components to a drive's heat sink, component-fastener torque sequences and tolerances are crucial to component-to-heat sink heat dissipation.



**ATTENTION:** Component can be damaged if temporary tightening procedure is not performed to specification.

The following illustrates temporary and final tightening sequences for components fastened to a heat sink using two, four, and six screws. Temporary torque is 1/3 (33%) of final torque, except six-point mountings, which require 0.5 N-m (4 lb-in.). The numeric illustration labels are for your assistance. Drive components do not carry these labels.

**Figure 2.1**  
Two-Point Mounting

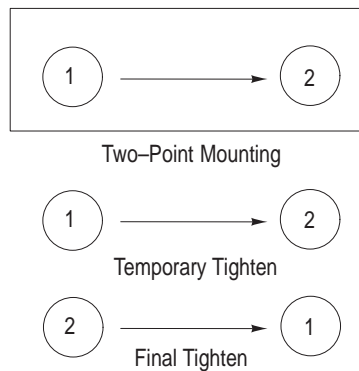

AB0016A

**Figure 2.2**  
**Four-Point Mounting**

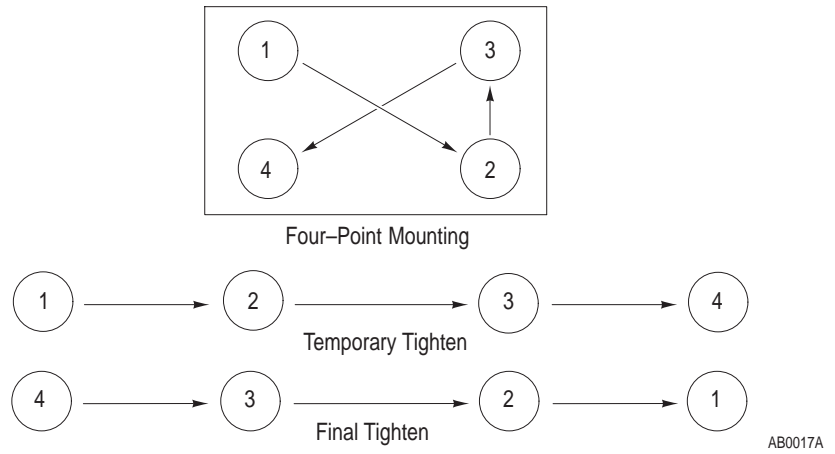

**Figure 2.3**  
**Six-Point Mounting**

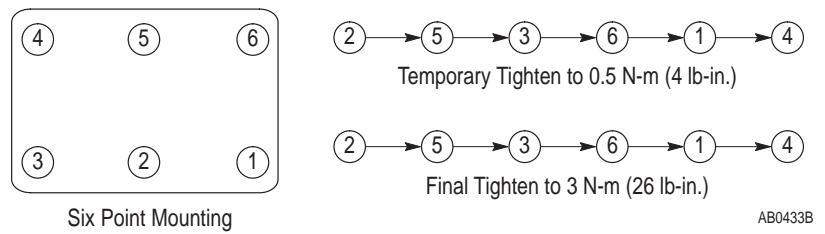

Note: Do not exceed 0.5 Newton-meters (4 lb-in.) on initial torque of all six screws.

### Torque Specifications

The following table lists fastener locations by component, how the fasteners are used, and torque specifications. Refer to Torque Sequence in this chapter for fastening two-point, four-point and six-point components to the heat sink.

**Table 2.A**  
**Fastener Torque Specifications**

Component	Fastener Application	Torque lb-in.	Torque N-m
Fan Motor	Motor to Fan Cover Assembly	14	2
Fan Cover Assembly	Assembly to chassis	26	3
Fan Transformer	Transformer to chassis	26	3
Fan Capacitor	Capacitor to chassis	Hand-tighten	
MOV Surge Suppressor	MOV to chassis	14	2
Snubber Resistor	Resistor to heat sink	26	3
Snubber Resistor	Wires to Capacitor Bus Bar Assembly	50	6
Snubber Bracket	Bracket to Power Module	80	9
Snubber Board	Board to Brackets	50	6
Snubber Board	Board to Input Rectifier	50	6
Volt Sharing Resistor	Resistor to heat sink	26	3
Volt Sharing Resistor	Wires to Capacitor Bus Bar Assembly	50	6
Thermistor	Thermistor to heatsink	14	2
Bus Capacitor Holder	Holder to Bus Capacitors	26	3
Capacitor Bus Bar Assembly	Assembly to Bus Capacitors	50	6
Power Module Gate Interface Board	Board to Power Modules	14	2
Power Module Bus Bar	Bus Bar to Power Modules	80	9
Power Module	Module to heat sink	Refer to Figure 2.3	
DIN Rail (TB1)	Rail to chassis	50	6
PE Shortening Bar	Bar to TB1	80	9
Input Rectifier	Rectifier to heat sink	50	6
Transitional Bus Bar Assembly	Assembly to Power Module Bus Bar Assembly	80	9
Bus Fuse F1	Fuse to Transitional Bus Bar Assembly	80	9
DC Bus Inductor L1	Inductor to chassis	50	6
Bus Bar Cable Adaptor	Adaptor to Transitional Bus Bar Assembly and DC Bus Inductor	80	9
Converter Bus and Motor Bus Bars	Bus Bars to all connections	80	9
Wires (PE)	Wires to Ground Stud	80	9
Wires	Wires to TB1	80	9
Wire (TE)	Wire to TB1	50	6
Wires	Wires to TB3	8 – 10	0.9 – 1.13
LEM Mounting Plate	Mounting Plate to LEM Clamping Plate	14	2
LEM Clamping Plate	Clamping Plate to Bus Bar	26	3
Power Cables	Cables to terminals	80	9
Main Control, Gate Driver, Precharge Board Mounting Plates	Plates to chassis	26	3
High Voltage Guard	Guard to chassis	26	3

## Disassembly and Access Procedures

### Opening the Drive Enclosure

Figure 2.4  
Drive Enclosure

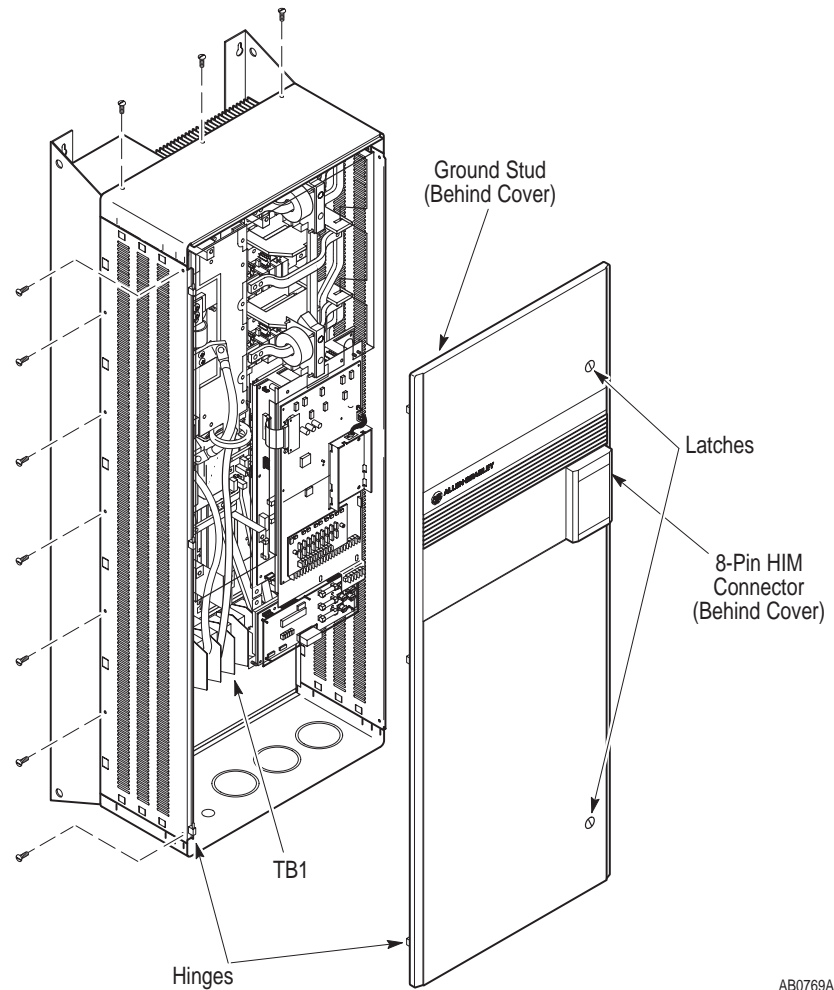

AB0769A

### Removal



**ATTENTION:** Disconnect and lock out power from the drive before disassembling the drive. Failure to disconnect power may result in death or serious injury. Verify bus voltage by measuring the voltage between +DC and -DC on Terminal Block TB1. Do not attempt to service the drive until the bus voltage has discharged to zero volts.





**ATTENTION:** Wear a wrist-type grounding strap when servicing 1336 FORCE Drives. Failure to protect drive components against ESD may damage drive components. Refer to Electrostatic Discharge Precautions at the beginning of this chapter.

---

1. Remove power from the drive.
2. Turn the Enclosure Cover latches, located on the right side of the cover, 90 degrees clockwise.
3. Open the Enclosure door.
4. Check for zero volts at TB1 terminals +DC and –DC.
5. Check for the absence of control voltage at:
  - TB20 and TB21 on drives using a PLC Comm Adapter Board
  - TB5, TB6, and TB7 on drives using a Standard Adapter Board
6. Remove the 8-pin HIM connector from the HIM holder and the ground wire from the ground stud on the inside of the door.
7. Disconnect the HIM cable and the ground wire from the clips inside the door.
8. Lift the cover up toward the top of the drive to disengage the cover from the hinges.
9. Remove the customer-supplied wiring from the drive.
10. Remove the Enclosure top and bottom panels.
11. Remove the Enclosure side panels.

### Installation

Install the Enclosure in reverse order of removal.



**ATTENTION:** Replace all guards before applying power to the drive. Failure to replace guards may result in death or serious injury.

---

## Removing the High Voltage Guard

The High Voltage Guard is a clear plastic guard covering the LEMs, Bus Capacitor Bank, and DC Bus Inductor.

**Figure 2.5**  
High Voltage Guard

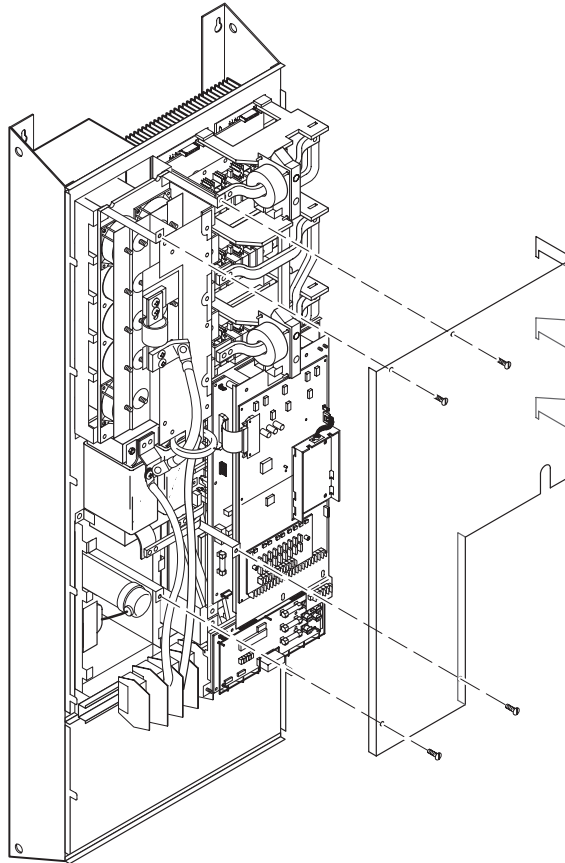

AB0771A

### Removal



**ATTENTION:** Disconnect and lock out power from the drive before disassembling the drive. Failure to disconnect power may result in death or serious injury. Verify bus voltage by measuring the voltage between +DC and -DC on Terminal Block TB1. Do not attempt to service the drive until the bus voltage has discharged to zero volts.



**ATTENTION:** Wear a wrist-type grounding strap when servicing 1336 FORCE Drives. Failure to protect drive components against ESD may damage drive components. Refer to Electrostatic Discharge Precautions at the beginning of this chapter.

---

1. Remove power from the drive.
2. Open the Enclosure cover if the drive has an enclosure. Refer to Opening the Drive Enclosure in this chapter.
3. Check for zero volts at TB1 terminals +DC and –DC.
4. Check for the absence of control voltage at:
  - TB20 and TB21 on drives using a PLC Comm Adapter Board
  - TB5, TB6, and TB7 on drives using a Standard Adapter Board
5. Remove the screws fastening the High Voltage Guard to the standoffs.
6. Lift the guard upward to disengage the tabs on the right side from the bus bar supports.
7. Pull the guard away from the drive.

#### Installation

Install the High Voltage Guard in reverse order of removal. Refer to Table 2.A – Fastener Torque Specifications.



**ATTENTION:** Replace all guards before applying power to the drive. Failure to replace guards may result in death or serious injury.

---

## Removing Control Interface L-Option Board MOD-L4, -L5, or -L6

Figure 2.6  
Control Interface Board

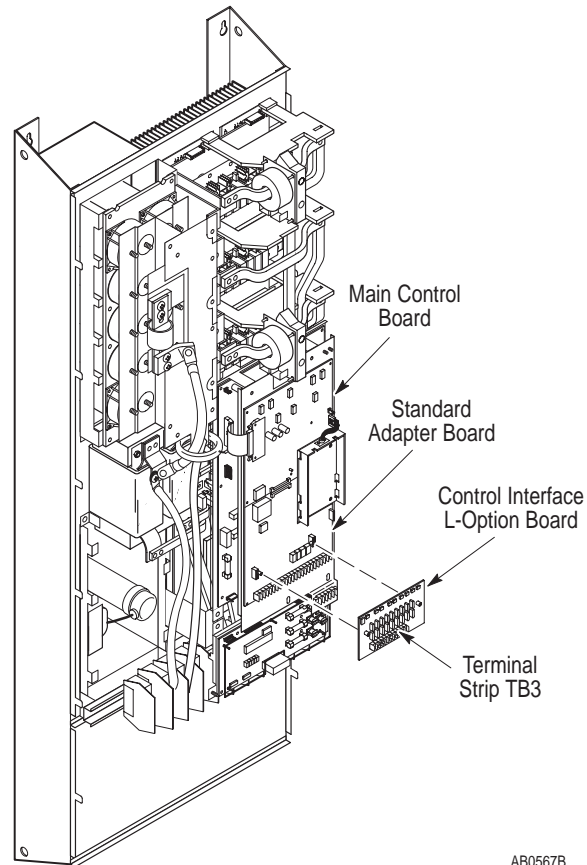

AB0567B

### Removal



**ATTENTION:** Disconnect and lock out power from the drive before disassembling the drive. Failure to disconnect power may result in death or serious injury. Verify bus voltage by measuring the voltage between +DC and -DC on Terminal Block TB1. Do not attempt to service the drive until the bus voltage has discharged to zero volts.



**ATTENTION:** Wear a wrist-type grounding strap when servicing 1336 FORCE Drives. Failure to protect drive components against ESD may damage drive components. Refer to Electrostatic Discharge Precautions at the beginning of this chapter.

**Important:** Before you remove connections and wires from the drive components, mark the connections and wires to correspond with their component connections and terminals to prevent incorrect wiring during assembly.

1. Remove power from the drive.
2. Open the Enclosure cover if the drive has an enclosure. Refer to Opening the Drive Enclosure in this chapter.
3. Check for zero volts at TB1 terminals +DC and –DC.
4. Check for the absence of control voltage at TB5, TB6, and TB7 on the Standard Adapter Board.
5. Remove all wires from the terminals on TB3.
6. Loosen the two captive screws fastening the Control Interface L-Option Board to the Standard Adapter Board.
7. Grip the right and left sides of the Control Interface Board and pull the board straight out from the Standard Adapter Board.

### Installation

Install the Control Interface L-Option Board in reverse order of removal.



**ATTENTION:** Replace all guards before applying power to the drive. Failure to replace guards may result in death or serious injury.

## Removing the Main Control Board

Figure 2.7  
Main Control Board

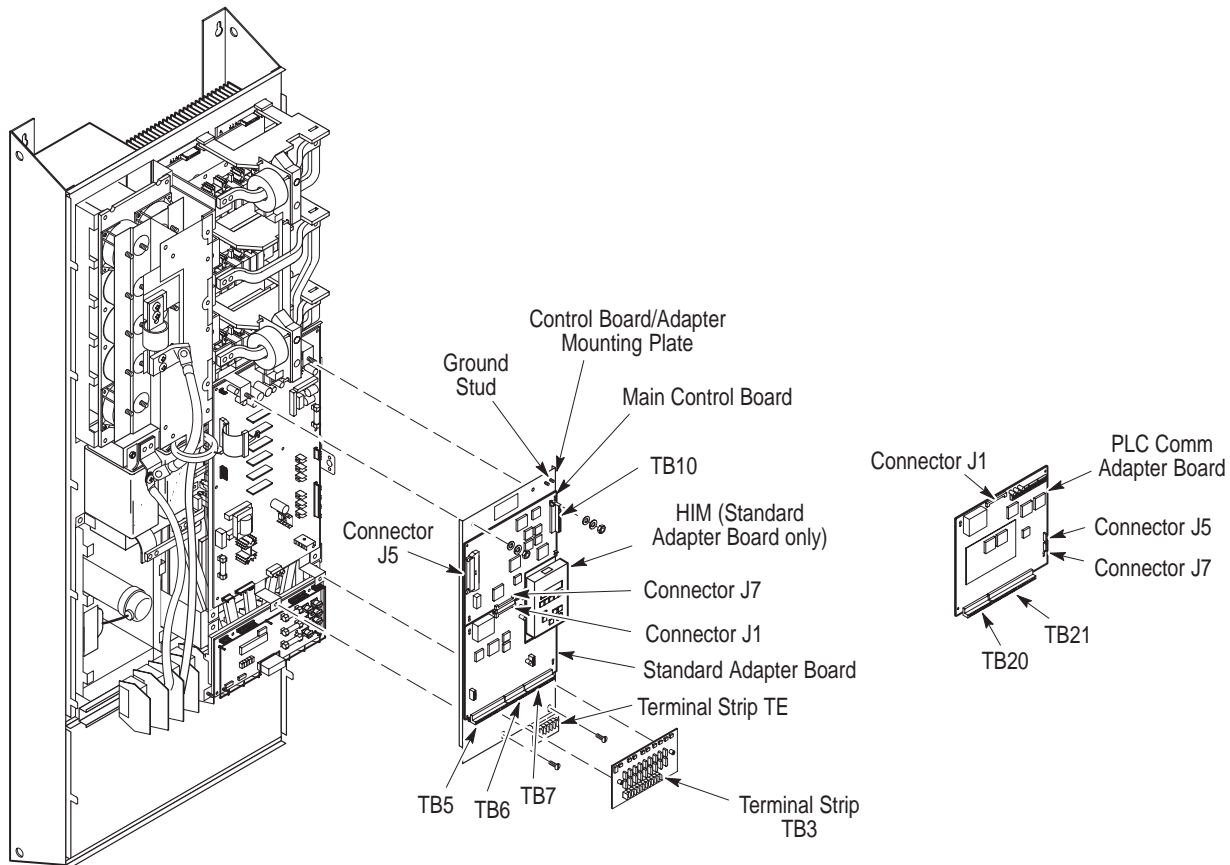

AB0568A

### Removal



**ATTENTION:** Disconnect and lock out power from the drive before disassembling the drive. Failure to disconnect power may result in death or serious injury. Verify bus voltage by measuring the voltage between +DC and -DC on Terminal Block TB1. Do not attempt to service the drive until the bus voltage has discharged to zero volts.



**ATTENTION:** Wear a wrist-type grounding strap when servicing 1336 FORCE Drives. Failure to protect drive components against ESD may damage drive components. Refer to Electrostatic Discharge Precautions at the beginning of this chapter.

**Important:** Before you remove connections and wires from the drive components, mark the connections and wires to correspond with their component connections and terminals to prevent incorrect wiring during assembly.

1. Remove power from the Drive.
2. Open the Enclosure cover. Refer to Opening the Drive Enclosure in this chapter.
3. Check for zero volts at TB1 Terminals +DC and –DC.
4. Check for the absence of control voltage at the terminals on the PLC Comm or Standard Adapter Boards.
5. Disconnect the following from the Main Control Board:
  - J1 connector
  - J5 ribbon cable connector
  - Stake-on ground wire connector
  - All wires from TB10
6. Remove the screws fastening the Main Control Board to the Control Board/Adapter Mounting Plate.
7. Slide the Main Control Board upward to release it from the slide-mount stand-offs and connector J7.

### Installation

Install the Main Control Board in reverse order of removal.



**ATTENTION:** Replace all guards before applying power to the drive. Failure to replace guards may result in death or serious injury.

---

## Removing the Standard Adapter Board

**Figure 2.8**  
Main Control Board and Standard Adapter Board

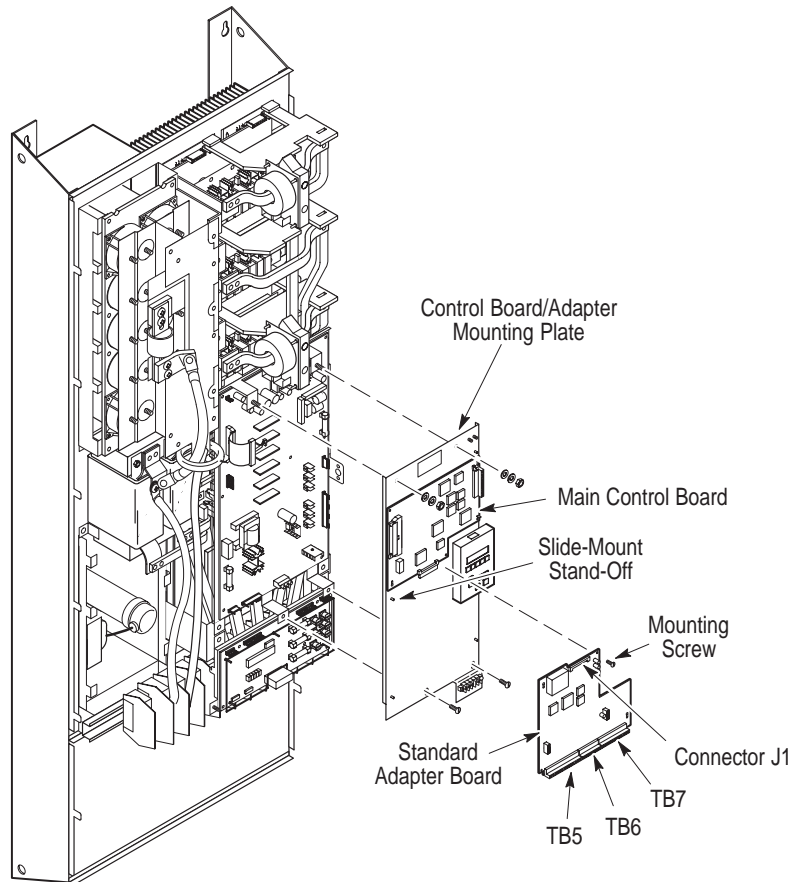

AB0573A

### Removal



**ATTENTION:** Disconnect and lock out power from the drive before disassembling the drive. Failure to disconnect power may result in death or serious injury. Verify bus voltage by measuring the voltage between +DC and -DC on Terminal Block TB1. Do not attempt to service the drive until the bus voltage has discharged to zero volts.



1. Remove power from the drive.
2. Open the Enclosure cover. Refer to Opening the Drive Enclosure in this chapter.
3. Check for zero volts at TB1 terminals +DC and –DC.
4. Check for the absence of control voltage at TB5, TB6, and TB7 on the Standard Adapter Board.
5. Disconnect the following from the Standard Adapter Board:
  - Stake-on ground wire connector
  - All wires from TB5, TB6, and TB7
6. Remove the Control Interface L-Option Board. Refer to Removing the Control Interface L-Option Board in this chapter.
7. Remove the two screws fastening the Standard Adapter Board to the Control Board/Adapter Mounting Plate.
8. Pull the Standard Adapter Board up to release it from the slide mount stand-offs and connector J1.

### Installation

Install the Standard Adapter Control Board in reverse order of removal.



**ATTENTION:** Replace all guards before applying power to the drive. Failure to replace guards may result in death or serious injury.

---

## Removing the PLC Comm Adapter Board

**Figure 2.9**  
Main Control Board and PLC Comm Adapter Board

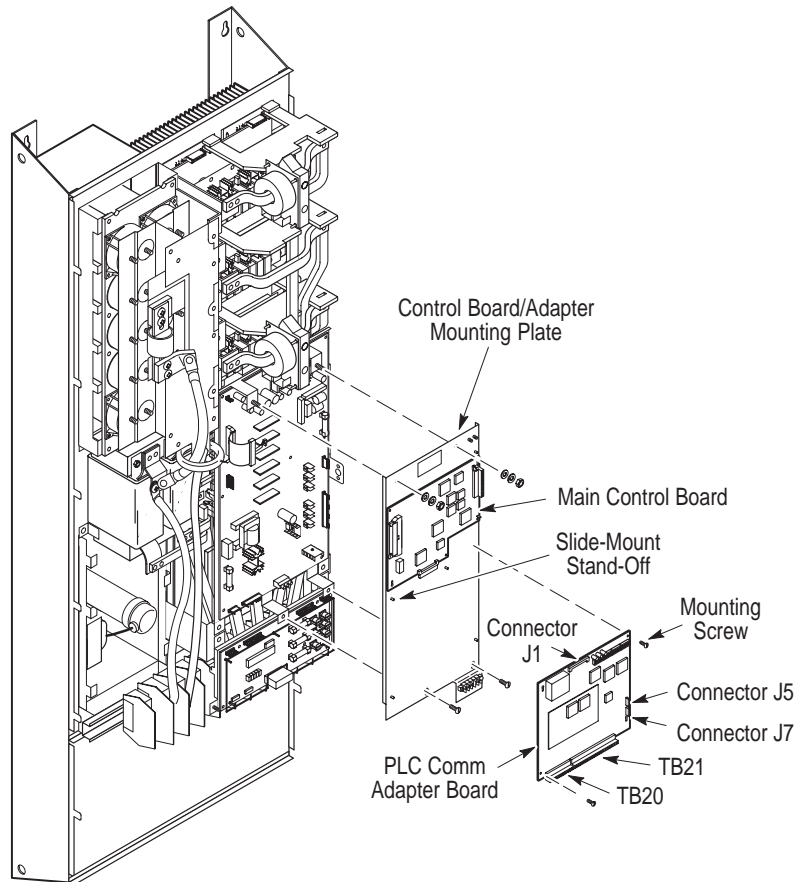

AB0574A

### Removal



**ATTENTION:** Disconnect and lock out power from the drive before disassembling the drive. Failure to disconnect power may result in death or serious injury. Verify bus voltage by measuring the voltage between +DC and -DC on Terminal Block TB1. Do not attempt to service the drive until the bus voltage has discharged to zero volts.

1. Remove power from the drive.
2. Open the Enclosure cover. Refer to Opening the Drive Enclosure in this chapter.
3. Check for zero volts at TB1 terminals +DC and –DC.
4. Check for the absence of control voltage at TB20 and TB21 on the PLC Comm Adapter Board.
5. Disconnect the following from the PLC Comm Adapter Board:
  - All wires from TB20 and TB21
  - Stake-on ground wire connector
  - J5 connector
  - J7 connector
  - Communication channel A and B connectors
6. Remove the screws fastening the PLC Comm Adapter Board to the Control Board/Adapter Mounting Plate.
7. Pull the PLC Comm Adapter Board down to release it from the slide-mount stand-offs and connector J1.

### Installation

Install the PLC Comm Adapter Board in reverse order of removal.



**ATTENTION:** Replace all guards before applying power to the drive. Failure to replace guards may result in death or serious injury.

## Removing the Control Board/Adapter Mounting Plate

Figure 2.10  
Control Board/Adapter Mounting Plate

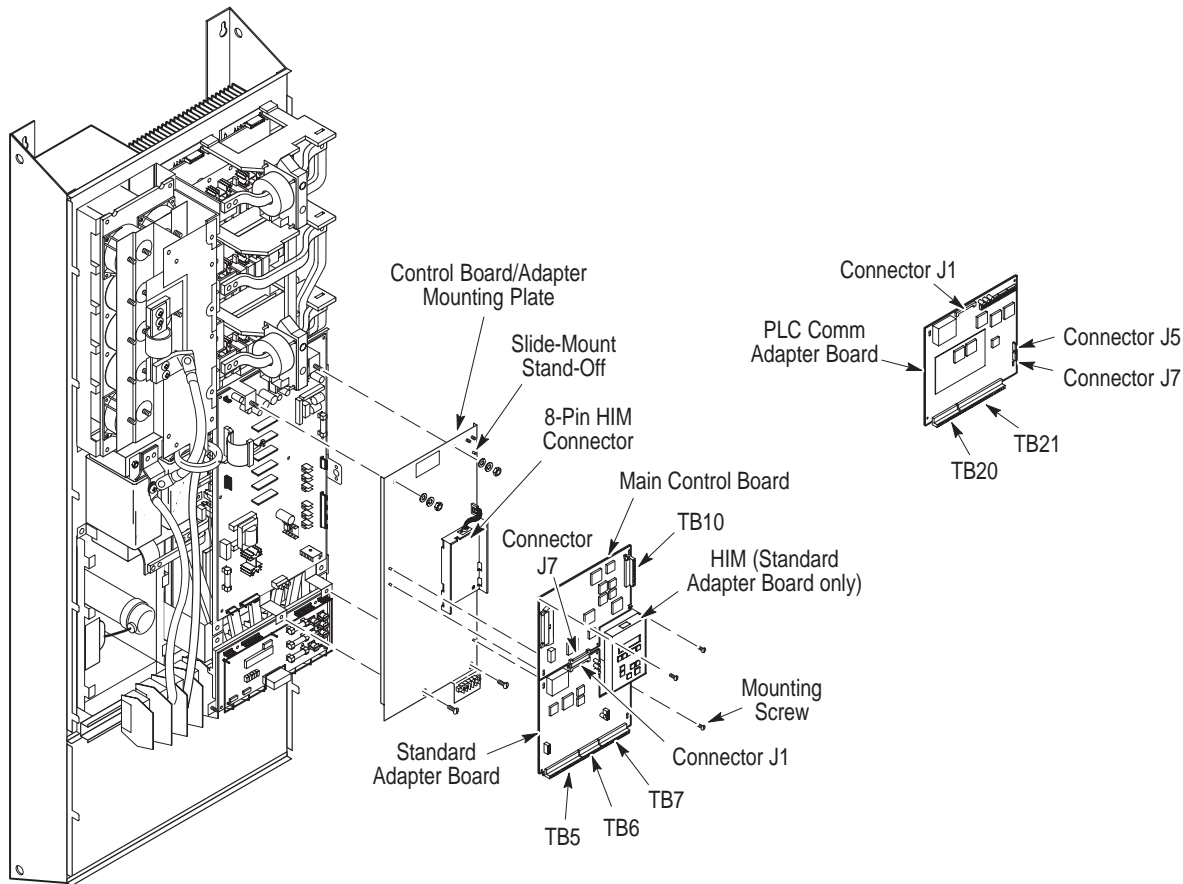

AB0569A

### Removal



**ATTENTION:** Disconnect and lock out power from the drive before disassembling the drive. Failure to disconnect power may result in death or serious injury. Verify bus voltage by measuring the voltage between +DC and -DC on Terminal Block TB1. Do not attempt to service the drive until the bus voltage has discharged to zero volts.



**ATTENTION:** Wear a wrist-type grounding strap when servicing 1336 FORCE Drives. Failure to protect drive components against ESD may damage drive components. Refer to Electrostatic Discharge Precautions at the beginning of this chapter.

**Important:** Before you remove connections and wires from the drive components, mark the connections and wires to correspond with their component connections and terminals to prevent incorrect wiring during assembly.

1. Remove power from the drive.
2. Open the Enclosure cover if the drive has an enclosure. Refer to Opening the Drive Enclosure in this chapter.
3. Check for zero volts at TB1 terminals +DC and –DC.
4. Check for the absence of control voltage at:
  - TB20 and TB21 on drives using a PLC Comm Adapter Board
  - TB5, TB6, and TB7 on drives using a Standard Adapter Board
5. Remove the wires and connectors from the Standard or PLC Comm Adapter Board.



This drive may have either a Standard Adapter Board or a PLC Comm Adapter Board. Refer to Removing the Standard Adapter Board or Removing the PLC Comm Adapter Board in this chapter.

6. Remove the wires and connectors from the Main Control Board. Refer to Removing the Main Control Board in this chapter.
7. Slide the LEM harness out of the clip located at the top-left of the Control Board/Adapter Mounting Plate.
8. Remove the two screws fastening the bottom of the Control Board/Adapter Mounting Plate to the standoffs.
9. Remove the nuts fastening the top of the Control Board/Adapter Mounting Plate to the Gate Driver Board Mounting Plate.
10. Lift the Control Board/Adapter Mounting Plate out of the drive.

### Installation

Install the Control Board/Adapter Mounting Plate in reverse order of removal. Refer to Table 2.A – Fastener Torque Specifications.



**ATTENTION:** Replace all guards before applying power to the drive. Failure to replace guards may result in death or serious injury.

## Removing The Gate Driver Board Mounting Plate

Figure 2.11  
Gate Driver Board Mounting Plate

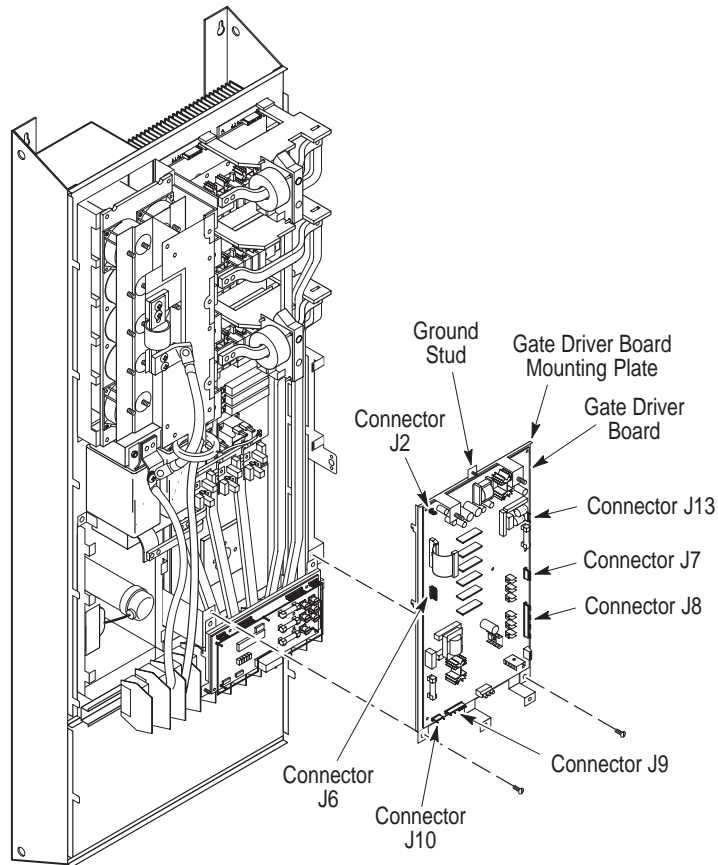

AB0439A

### Removal



**ATTENTION:** Disconnect and lock out power from the drive before disassembling the drive. Failure to disconnect power may result in death or serious injury. Verify bus voltage by measuring the voltage between +DC and -DC on Terminal Block TB1. Do not attempt to service the drive until the bus voltage has discharged to zero volts.



**ATTENTION:** Wear a wrist-type grounding strap when servicing 1336 FORCE Drives. Failure to protect drive components against ESD may damage drive components. Refer to Electrostatic Discharge Precautions at the beginning of this chapter.

**Important:** Before you remove connections and wires from the drive components, mark the connections and wires to correspond with their component connections and terminals to prevent incorrect wiring during assembly.

1. Remove power from the drive.
2. Open the Enclosure cover. Refer to Opening the Drive Enclosure in this chapter.
3. Check for zero volts at TB1 terminals +DC and –DC.
4. Check for the absence of control voltage at:
  - TB20 and TB21 on drives using a PLC Comm Adapter Board
  - TB5, TB6, and TB7 on drives using a Standard Adapter Board
5. Remove the Control Board/Adapter Mounting Plate. Refer to Removing the Control Board/Adapter Mounting Plate in this chapter.
6. Disconnect the following from the Gate Driver Board:
  - J2 connector
  - J6 connector
  - J7 connector
  - J8 connector
  - J9 connector
  - J10 connector
  - J13 connector
  - TB6 High Voltage Aux. Input
  - Ground wire from the top of the Gate Driver Board Mounting Plate.
7. Remove the screws fastening the bottom of the Gate Driver Board Mounting Plate to the chassis.
8. Slide the plate toward the top of the drive to disengage the mounting plate tabs from the slots on the chassis.

### Installation

Install the Gate Driver Board Mounting Plate in reverse order of removal. Refer to Table 2.A – Fastener Torque Specifications.



**ATTENTION:** When removing the entire wire harness connecting Gate Driver Board connector J9 to Precharge Board connector J3, align the wires on the harness terminals with the pins on the board connectors. Incorrect harness connection may result in faulty drive operation and may damage the equipment.

---



**ATTENTION:** Replace all guards before applying power to the drive. Failure to replace guards may result in death or serious injury.

---



## Removing the Gate Driver Board

Figure 2.12  
Gate Driver Board and Mounting Plate

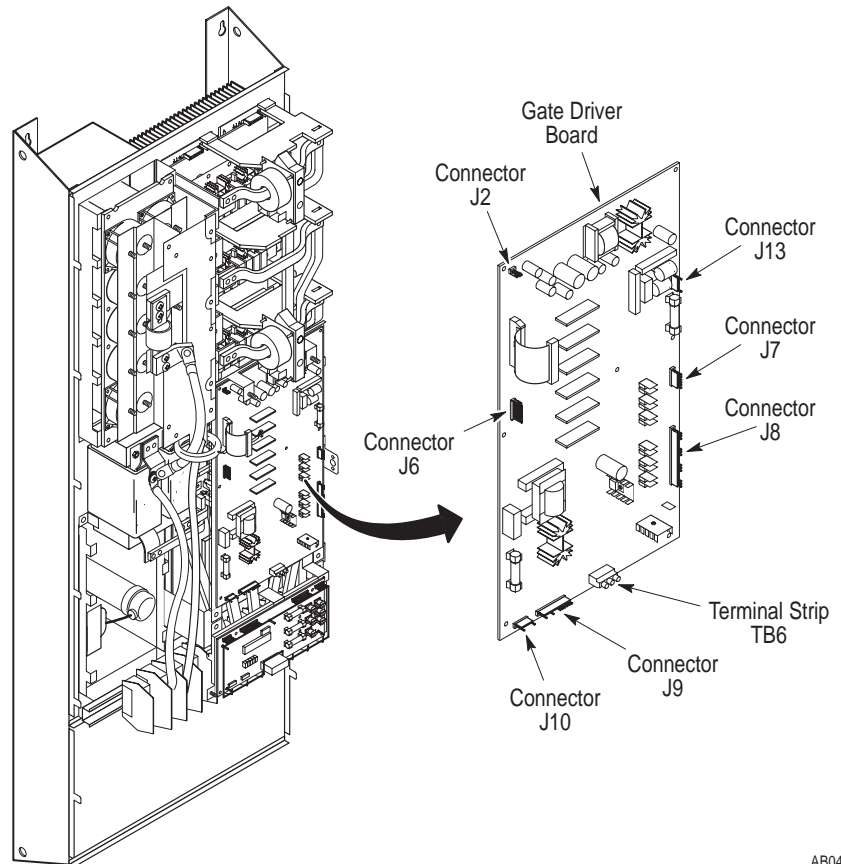

AB0440A

### Removal



**ATTENTION:** Disconnect and lock out power from the drive before disassembling the drive. Failure to disconnect power may result in death or serious injury. Verify bus voltage by measuring the voltage between +DC and -DC on Terminal Block TB1. Do not attempt to service the drive until the bus voltage has discharged to zero volts.



**ATTENTION:** Wear a wrist-type grounding strap when servicing 1336 FORCE Drives. Failure to protect drive components against ESD may damage drive components. Refer to Electrostatic Discharge Precautions at the beginning of this chapter.

**Important:** Before you remove connections and wires from the drive components, mark the connections and wires to correspond with their component connections and terminals to prevent incorrect wiring during assembly.

1. Remove power from the drive.
2. Open the Enclosure if the drive has an Enclosure. Refer to Opening the Drive Enclosure in this chapter.
3. Check for zero volts at TB1 terminals +DC and –DC.
4. Check for the absence of control voltage at:
  - TB20 and TB21 on drives using a PLC Comm Adapter Board
  - TB5, TB6, and TB7 on drives using a Standard Adapter Board
5. Remove the Control Board/Adapter Mounting Plate. Refer to Removing the Control Board/Adapter Mounting Plate in this chapter.
6. Disconnect the following from the Gate Driver Board:
  - J2 connector
  - J6 connector
  - J7 connector
  - J8 connector
  - J9 connector
  - J10 connector
  - J13 connector
  - TB6 High Voltage Aux. Input
  - Ground wire from the top of the Gate Driver Board Mounting Plate.
7. Turn the eight standoff screws, fastening the Gate Driver Board to the Mounting Plate, 1/4 turn counterclockwise.
8. Pull the Gate Driver Board away from the Gate Driver Board Mounting Plate.

### Installation

Install the Gate Driver Board in reverse order of removal.



**ATTENTION:** When removing the entire wire harness connecting Gate Driver Board connector J9 to Precharge Board connector J3, align the wires on the harness terminals with the pins on the board connectors. Incorrect harness connection may result in faulty drive operation and may damage the equipment.

---



**ATTENTION:** Replace all guards before applying power to the drive. Failure to replace guards may result in death or serious injury.

## Removing the Precharge Board Mounting Plate

Figure 2.13  
Precharge Board Mounting Plate

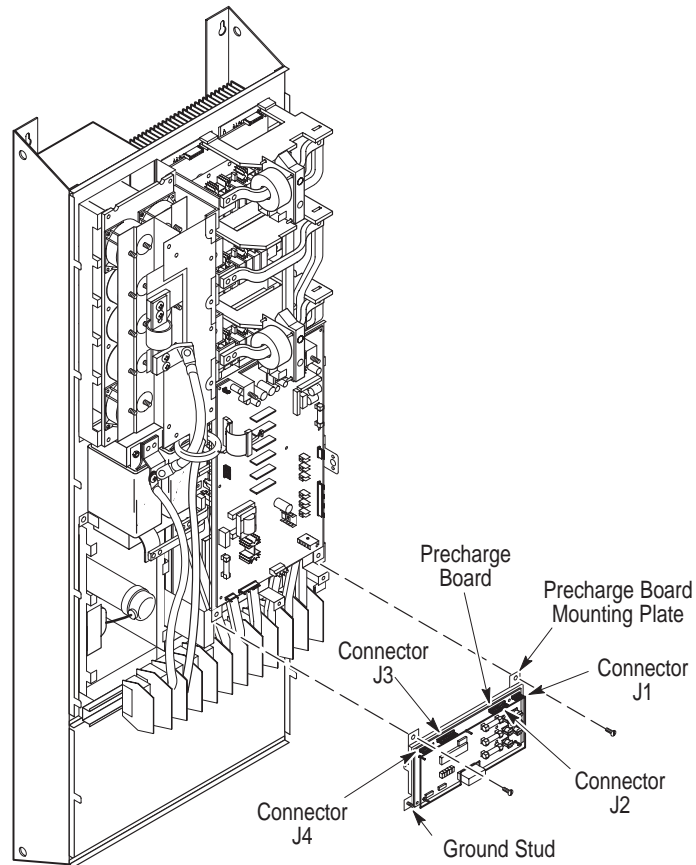

## Removal



**ATTENTION:** Disconnect and lock out power from the drive before disassembling the drive. Failure to disconnect power may result in death or serious injury. Verify bus voltage by measuring the voltage between +DC and -DC on Terminal Block TB1. Do not attempt to service the drive until the bus voltage has discharged to zero volts.



**ATTENTION:** Wear a wrist-type grounding strap when servicing 1336 FORCE Drives. Failure to protect drive components against ESD may damage drive components. Refer to Electrostatic Discharge Precautions at the beginning of this chapter.

---

**Important:** Before you remove connections and wires from the drive components, mark the connections and wires to correspond with their component connections and terminals to prevent incorrect wiring during assembly.

1. Remove power from the drive.
2. Open the Enclosure if the drive has an Enclosure. Refer to Opening the Drive Enclosure in this chapter.
3. Check for zero volts at TB1 terminals +DC and -DC.
4. Check for the absence of control voltage at:
  - TB20 and TB21 on drives using a PLC Comm Adapter Board
  - TB5, TB6, and TB7 on drives using a Standard Adapter Board
5. Remove the High Voltage Guard.
6. Disconnect the following from the Precharge Board:
  - J1 connector
  - J2 connector
  - J3 connector
  - J4 connector
  - Ground wire from the stud at the bottom left of the mounting plate.
7. Remove the screws fastening the top of the Precharge Board Mounting Plate to the chassis.
8. Slide the Precharge Board Mounting Plate toward the bottom of the drive to disengage the tabs from the slots in the chassis.
9. Pull the Precharge Board Mounting Plate out of the enclosure.

### Installation

Install the Precharge Board Mounting Plate in reverse order of removal. Refer to Table 2.A – Fastener Torque Specifications.



**ATTENTION:** When removing the entire wire harness connecting Gate Driver Board connector J9 to Precharge Board connector J3, align the wires on the harness terminals with the pins on the board connectors. Incorrect harness connection may result in faulty drive operation and may damage the equipment.

---



**ATTENTION:** Replace all guards before applying power to the drive. Failure to replace guards may result in death or serious injury.

## Removing the Precharge Board

Figure 2.14  
Precharge Board

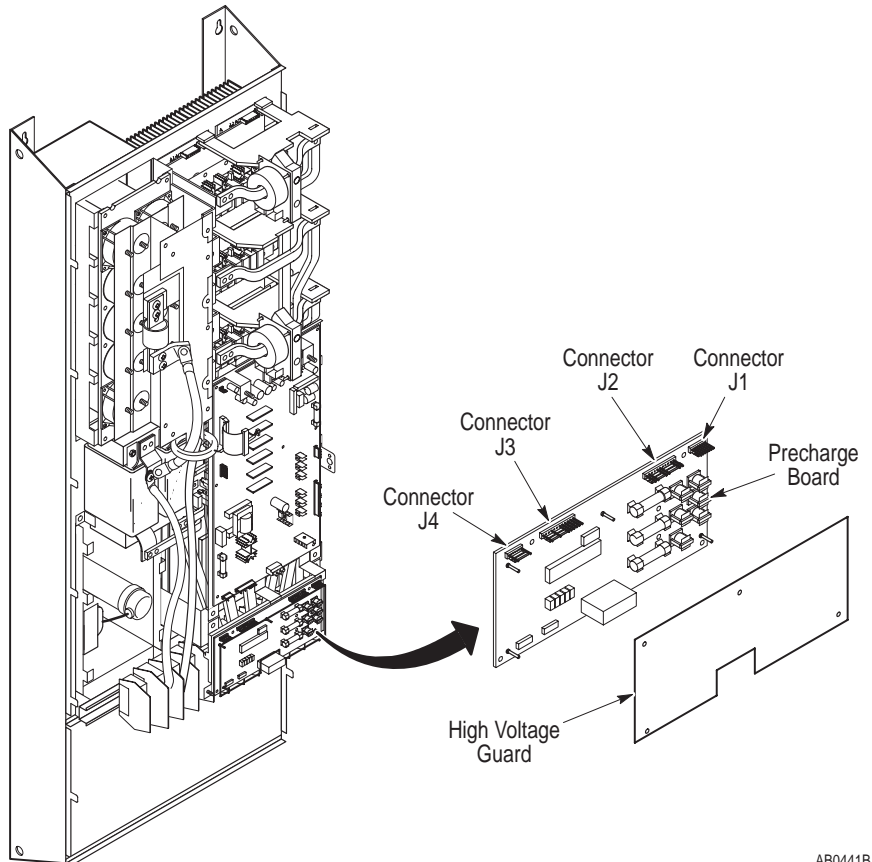

AB0441B

## Removal



**ATTENTION:** Disconnect and lock out power from the drive before disassembling the drive. Failure to disconnect power may result in death or serious injury. Verify bus voltage by measuring the voltage between +DC and -DC on Terminal Block TB1. Do not attempt to service the drive until the bus voltage has discharged to zero volts.



**ATTENTION:** Wear a wrist-type grounding strap when servicing 1336 FORCE Drives. Failure to protect drive components against ESD may damage drive components. Refer to Electrostatic Discharge Precautions at the beginning of this chapter.

---

**Important:** Before you remove connections and wires from the drive components, mark the connections and wires to correspond with their component connections and terminals to prevent incorrect wiring during assembly.

1. Remove power from the drive.
2. Open the Enclosure if the drive has an Enclosure. Refer to Opening the Drive Enclosure in this chapter.
3. Check for zero volts at TB1 terminals +DC and -DC.
4. Check for the absence of control voltage at:
  - TB20 and TB21 on drives using a PLC Comm Adapter Board
  - TB5, TB6, and TB7 on drives using a Standard Adapter Board
5. Pull the Precharge Board High Voltage Guard away from the four guard supports.
6. Disconnect the following from the Precharge Board:
  - J1 connector
  - J2 connector
  - J3 connector
  - J4 connector
7. Turn the six standoff screws, fastening the Precharge Board to the Precharge Board Mounting Plate, 1/4 turn counterclockwise.
8. Pull the Precharge Board away from the Precharge Board Mounting Plate.

### Installation

Install the Precharge Board in reverse order of removal.



**ATTENTION:** When removing the entire wire harness connecting Gate Driver Board connector J9 to Precharge Board connector J3, align the wires on the harness terminals with the pins on the board connectors. Incorrect harness connection may result in faulty drive operation and may damage the equipment.

---



**ATTENTION:** Replace all guards before applying power to the drive. Failure to replace guards may result in death or serious injury.

## Removing a Power Module Snubber Board

The Power Module Snubber Boards are located under the Motor Bus Bars and LEMs.

**Figure 2.15**  
Power Module Snubber Board

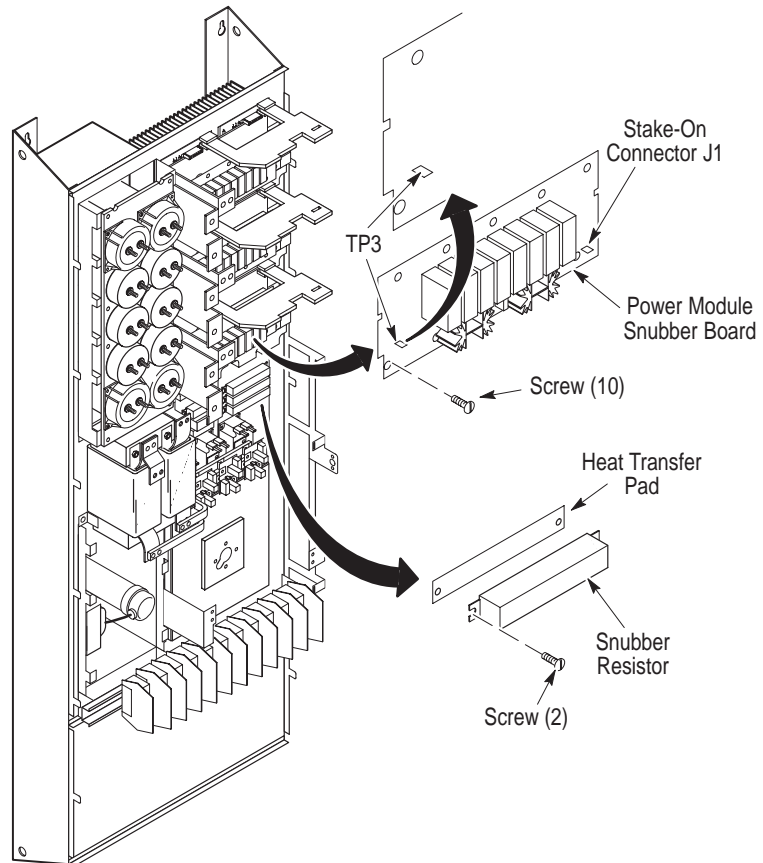

AB0443B

---

## Removal

---



**ATTENTION:** Disconnect and lock out power from the drive before disassembling the drive. Failure to disconnect power may result in death or serious injury. Verify bus voltage by measuring the voltage between +DC and –DC on Terminal Block TB1. Do not attempt to service the drive until the bus voltage has discharged to zero volts.

---



**ATTENTION:** Hazard of electric shock exists. Up to 1,600 VDC will be on J1 if the Snubber Resistor is open. Measure for zero VDC from Snubber Board terminal TP3 to plus (+) bus before removing connector J1. Use a resistor greater than 1 ohm and less than 100 ohm, rated for 25 watts minimum, between TP3 and plus (+) bus to discharge any voltage.

---



**ATTENTION:** Wear a wrist-type grounding strap when servicing 1336 FORCE Drives. Failure to protect drive components against ESD may damage drive components. Refer to Electrostatic Discharge Precautions at the beginning of this chapter.

---

**Important:** Before you remove connections and wires from the drive components, mark the connections and wires to correspond with their component connections and terminals to prevent incorrect wiring during assembly.

1. Remove power from the drive.
2. Open the Enclosure if the drive has an Enclosure. Refer to Opening the Drive Enclosure in this chapter.
3. Check for zero volts at TB1 terminals +DC and –DC.
4. Check for the absence of control voltage at:
  - TB20 and TB21 on drives using a PLC Comm Adapter Board
  - TB5, TB6, and TB7 on drives using a Standard Adapter Board
5. Remove the Gate Driver Board Mounting Plate. Refer to Removing the Gate Driver Board Mounting Plate in this chapter.
6. Remove the Precharge Board Mounting Plate. Refer to Removing the Precharge Board Mounting Plate in this chapter.
7. Remove the wires from the connectors on the LEMs.



8. Remove the Motor Bus Bars. LEMs are attached to two of these bars.
9. Remove the Motor Bus Bars from TB1 terminals U-M1, V-M2, and W-M3.
10. Slide the notches in the Motor Bus Bars away from the slots in the Motor Bus Bar Support to remove the Motor Bus Bars from the Drive.
11. Remove the Snubber Resistor wire from the Power Module Snubber Board stake-on connector J1.
12. Remove the screws fastening the Power Module Snubber Board to the Snubber Bracket to remove the Snubber Boards.

**Important:** Check the Snubber Resistor with a VOM. The reading should be 8 ohms. If open, replace the Snubber Resistor.

### Installation



**ATTENTION:** Do not substitute longer or shorter hardware when fastening the Power Module components to the Power Modules. Use the same size fastener to fasten the components as was originally used. Using different fastener lengths will damage the Power Modules.

---

Install the Power Module Snubber Board in reverse order of removal. Refer to Table 2.A – Fastener Torque Specifications.

**Important:** Install washers on TB1 terminals with the serrated side facing toward you.



**ATTENTION:** Replace all guards before applying power to the drive. Failure to replace guards may result in death or serious injury.

---

## Removing an Input Rectifier Snubber Board

The Input Rectifier Snubber Boards are located under the Gate Driver Board Mounting Plate.

Figure 2.16  
Input Rectifier Snubber Board

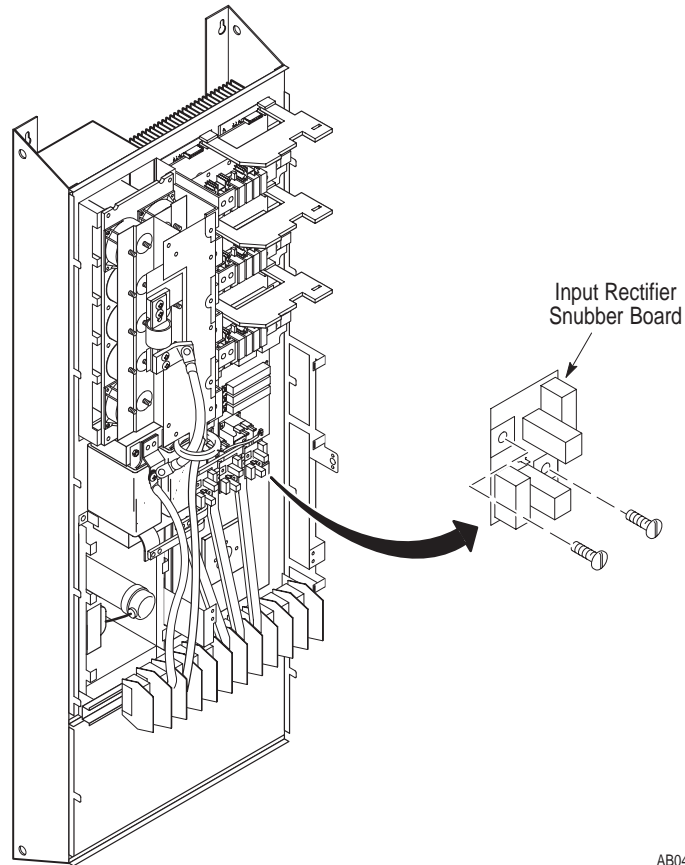

### Removal



**ATTENTION:** Disconnect and lock out power from the drive before disassembling the drive. Failure to disconnect power may result in death or serious injury. Verify bus voltage by measuring the voltage between +DC and -DC on Terminal Block TB1. Do not attempt to service the drive until the bus voltage has discharged to zero volts.



**ATTENTION:** Wear a wrist-type grounding strap when servicing 1336 FORCE Drives. Failure to protect drive components against ESD may damage drive components. Refer to Electrostatic Discharge Precautions at the beginning of this chapter.

---

**Important:** Before you remove connections and wires from the drive components, mark the connections and wires to correspond with their component connections and terminals to prevent incorrect wiring during assembly.

1. Remove power from the drive.
2. Open the Enclosure if the drive has an Enclosure. Refer to Opening the Drive Enclosure in this chapter.
3. Check for zero volts at TB1 terminals +DC and -DC.
4. Check for the absence of control voltage at:
  - TB20 and TB21 on drives using a PLC Comm Adapter Board
  - TB5, TB6, and TB7 on drives using a Standard Adapter Board
5. Remove the Control Board/Adapter Mounting Plate. Refer to Removing the Control Board/Adapter Mounting Plate in this chapter.
6. Remove the Gate Driver Board Mounting Plate. Refer to Removing the Gate Driver Board Mounting Plate in this chapter.
7. Remove the wire from Input Rectifier Snubber Board stake-on connector J1.
8. Remove the two screws fastening the Input Rectifier Snubber Input Rectifier Board to the Converter Snubber "Z" bracket.

### Installation

Install the snubber board in reverse order of removal. Refer to Table 2.A – Fastener Torque Specifications.



**ATTENTION:** Replace all guards before applying power to the drive. Failure to replace guards may result in death or serious injury.

---

### Accessing Power Plane Components

To access the power plane components located on the chassis, refer to Removing a Power Module Snubber Board in this chapter.

**This Page Intentionally Left Blank**

## Component Test Procedures

### Chapter Objectives

The following tests help you troubleshoot B150 – B250 and C150 – C250, and CX300 drives.

### Component Test Overview

In some cases, different tests troubleshoot components of the same name.

These similar tests vary according to the rating of the drive being tested. Verify that the rating on the drive matches the rating for the test you are performing.

The procedures in this chapter assume that the drive you are servicing either has no enclosure or that the enclosure is opened. For more information on opening the Drive Enclosure, refer to Chapter 2 – Disassembly and Access Procedures, Opening the Drive Enclosure.



**ATTENTION:** Some printed circuit boards and drive components may contain hazardous voltage levels. Remove and lock out power before you disconnect or reconnect wires, and before you remove or replace fuses and circuit boards. Verify bus voltage by measuring the voltage between +DC and –DC on Terminal Block TB1. Do not attempt to service the drive until the bus voltage has discharged to zero volts.

---



**ATTENTION:** Servicing energized industrial control equipment can be hazardous. Electrical shock, burns, or unintentional actuation of controlled industrial equipment may cause death or serious injury. Follow the safety-related practices of NFPA 70E, Electrical Safety for Employee Workplaces, when working on or near energized equipment. Do not work alone on energized equipment.

---

## Electrostatic Discharge Precautions



---

**ATTENTION:** This assembly contains parts and sub-assemblies that are sensitive to electrostatic discharge. Static control precautions are required when servicing this assembly. Component damage may result if you ignore electrostatic discharge control procedures. If you are not familiar with static control procedures, reference Allen-Bradley Publication 8000-4.5.2, Guarding Against Electrostatic Discharge, or any other applicable ESD protection handbook.

---

Electrostatic discharge generated by static electricity can damage the complimentary metallic oxide semiconductor devices on various drive boards. It is recommended that you perform these procedures to guard against this type of damage when circuit boards are removed or installed:

- Wear a wrist-type grounding strap that is grounded to the chassis.
- Attach the wrist strap before removing the new circuit board from the conductive packet.
- Remove boards from the drive and immediately insert them into their conductive packets.

### Tools

You need the following tools to disassemble and assemble the drive:

- Pliers
- Phillips screwdrivers (medium and large)
- Standard screwdrivers (small, medium, and large)
- 25/64-inch or 10 mm socket
- 7/16-inch or 11 mm socket
- 33/64-inch or 13 mm deep-well socket
- 5/16-inch or 8 mm open-end wrench
- Torque wrench, metered in lb-in. or N-m
- Nylon tie wraps

# Test 1 Testing the Gate Driver Board

The Gate Driver Board is located between the Main Control Board and the Main Chassis. If modules have been replaced, you must test the Gate Driver Board.

Figure 3.1  
Gate Driver Board Test

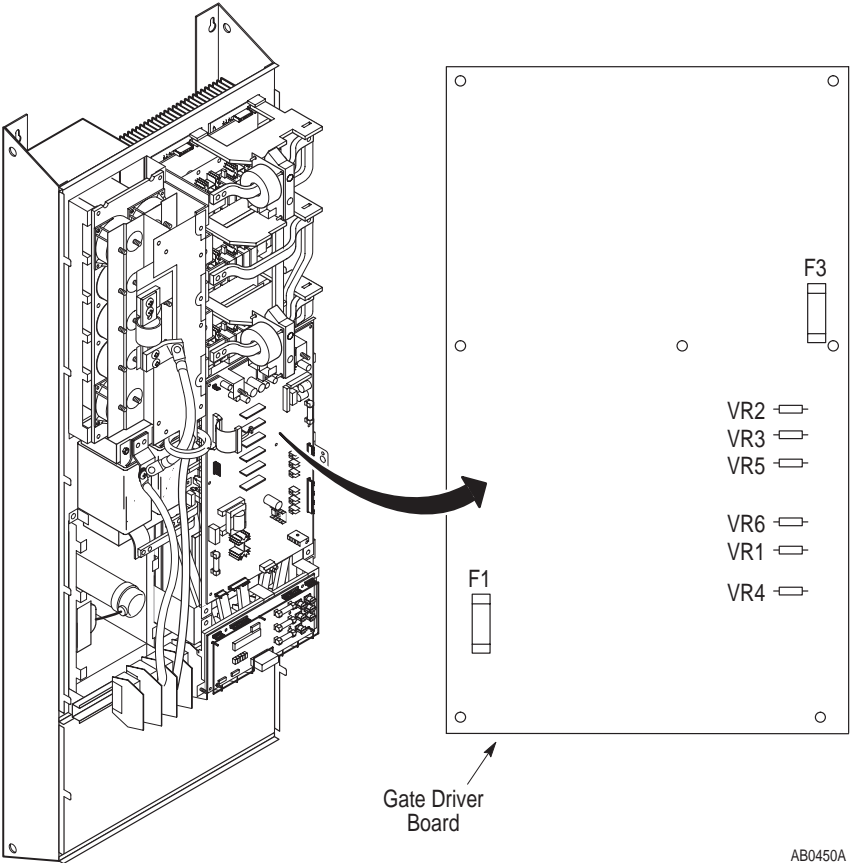

AB0450A



**ATTENTION:** Disconnect and lock out power from the drive before disassembling the drive. Failure to disconnect power may result in death or serious injury. Verify bus voltage by measuring the voltage between +DC and -DC on Terminal Block TB1. Do not attempt to service the drive until the bus voltage has discharged to zero volts.

**Important:** Before you remove connections and wires from the drive components, mark the connections and wires to correspond with their component connections and terminals to prevent incorrect wiring during assembly.

1. Remove power from the drive.
2. Check for zero volts at TB1 terminals +DC and –DC.
3. Check for absence of control voltage at:
  - TB20 and TB21 on drives using a PLC Comm Adapter Board
  - TB5, TB6, and TB7 on drives using a Standard Adapter Board
4. Remove the Control Board/Adapter Mounting Plate. Refer to Chapter 2 – Disassembly and Access Procedures, Removing the Control Board/Adapter Mounting Plate.
5. Unplug the connectors from the Gate Driver Board.
6. Set your meter to test resistance.
7. Test Fuses F1 and F3 for an open condition. Replace the Gate Driver Board if either fuse shows an open condition.
8. Set your meter to test diodes.
9. Test VR1 – VR6. The following table shows meter connections at the components and ideal meter readings for those connections. Refer to the former illustration for component locations.

**Table 3.A**  
**Gate Driver Board Test**

Component	Meter (+) Lead	Meter (–) Lead	Nominal Meter Reading*
VR1 – VR6	+	–	1.06
	–	+	1.8

**Note:** Typical malfunction is shorted in both directions.

\* Meter Used: Fluke® Model 87, set to “Diode” range.

10. Replace the Gate Driver Board if your readings do not match the table readings. Refer to Chapter 2 – Disassembly and Access Procedures, Removing the Gate Driver Board.
11. Assemble the drive in reverse order of disassembly.



**ATTENTION:** Replace all guards before applying power to the drive. Failure to replace guards may result in death or serious injury.



## Test 2 Testing the Precharge Board

If modules have been replaced, you must check the Power Module Snubber Board and the Precharge Board. Refer to Chapter 2 – Disassembly and Access Procedures, Removing a Power Module Snubber Board and Removing the Precharge Board Mounting Plate.

Figure 3.2  
Precharge Board Test

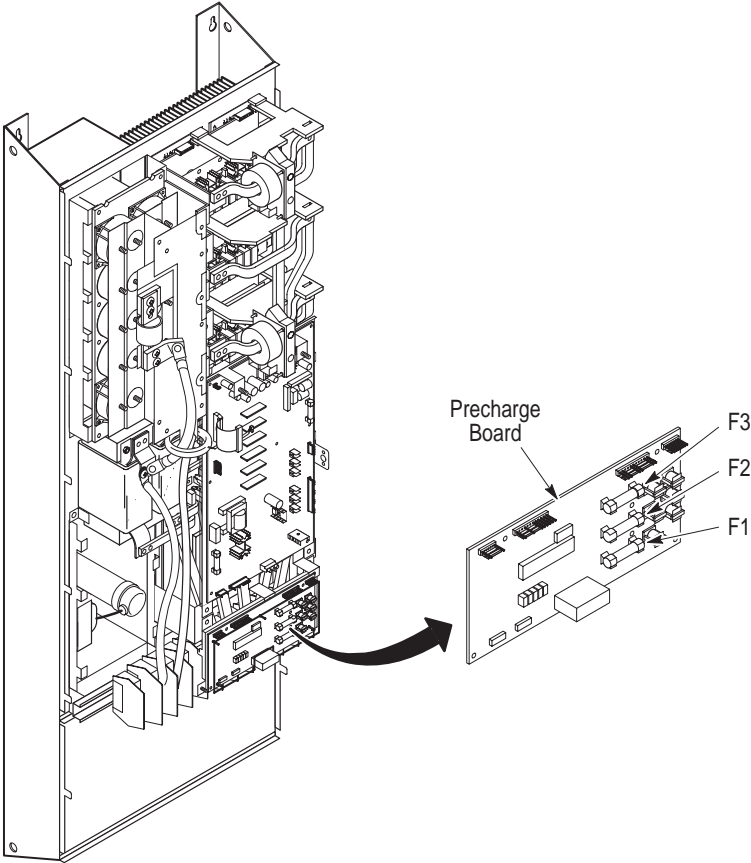

AB0451A



**ATTENTION:** Disconnect and lock out power from the drive before disassembling the drive. Failure to disconnect power may result in death or serious injury. Verify bus voltage by measuring the voltage between +DC and -DC on Terminal Block TB1. Do not attempt to service the drive until the bus voltage has discharged to zero volts.

**Important:** Before you remove connections and wires from the drive components, mark the connections and wires to correspond with their component connections and terminals to prevent incorrect wiring during assembly.

1. Remove power from the drive.
2. Check for zero volts at TB1 terminals +DC and -DC.
3. Check for absence of control voltage at:
  - TB20 and TB21 on drives using a PLC Comm Adapter Board
  - TB5, TB6, and TB7 on drives using a Standard Adapter Board
4. Set your meter to test resistance.
5. Test fuses F1, F2, and F3 for open conditions.
6. Replace the Precharge Board if any fuse shows an open condition. Refer to Chapter 2 – Disassembly and Access Procedures, Removing the Precharge Board.



**ATTENTION:** Replace all guards before applying power to the drive. Failure to replace guards may result in death or serious injury.

---

### Test 3 Testing the Power Modules

The Power Modules are located near the top of the heat sink. If modules have been replaced, you must check the Power Module Snubber Board. Refer to Chapter 2 – Disassembly and Access Procedures, Removing a Power Module Snubber Board.



**ATTENTION:** Hazard of electric shock exists. Up to 1,600 VDC will be on J1 if the Snubber Resistor is open. Measure for zero VDC from Snubber Board terminal TP3 to plus (+) bus before removing connector J1. Use a resistor greater than 1 ohm and less than 100 ohm, rated for 25 watts minimum, between TP3 and plus (+) bus to discharge any voltage. Refer to Chapter 2 – Disassembly and Access Procedures, Removing a Power Module Snubber Board.

Figure 3.3  
Power Module Test

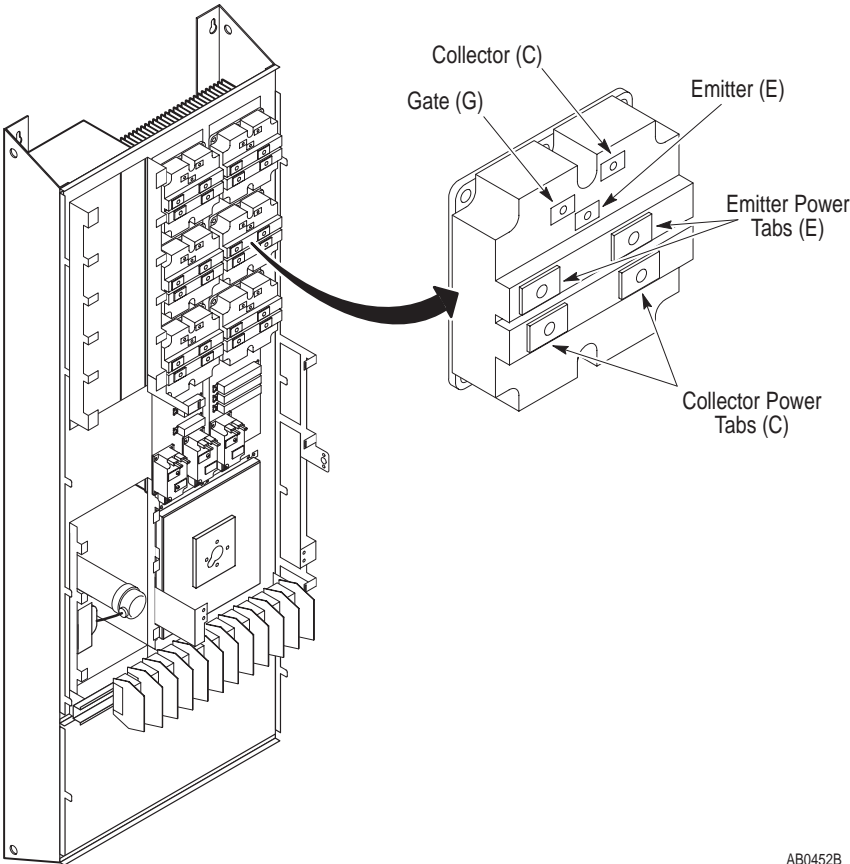

AB0452B



**ATTENTION:** Disconnect and lock out power from the drive before disassembling the drive. Failure to disconnect power may result in death or serious injury. Verify bus voltage by measuring the voltage between +DC and –DC on Terminal Block TB1. Do not attempt to service the drive until the bus voltage has discharged to zero volts.

---

**Important:** Before you remove connections and wires from the drive components, mark the connections and wires to correspond with their component connections and terminals to prevent incorrect wiring during assembly.

1. Remove power from the drive.
2. Check for zero volts at TB1 terminals +DC and –DC.
3. Check for absence of control voltage at:
  - TB20 and TB21 on drives using a PLC Comm Adapter Board
  - TB5, TB6, and TB7 on drives using a Standard Adapter Board
4. Remove the Gate Driver Board Mounting Plate. Refer to Chapter 2 – Disassembly and Access Procedures, Removing the Gate Driver/Precharge Board Mounting Plate.
5. Remove the Power Module Snubber Boards. Refer to Chapter 2 – Disassembly and Access Procedures, Removing a Power Module Snubber Board.
6. Set your meter to test diodes.
7. Test the Power Modules. The following table shows meter connections and ideal meter readings for those connections. Refer to the former illustration for meter connection locations.

Table 3.B  
Power Modules

Meter (+) Lead	Meter (-) Lead	Nominal Meter Reading
E	C	0.318
E	G	Infinite
C	E	Infinite
C	G	Infinite
G	E	Infinite
G	C	Infinite

- 8. Replace a Power Module if meter readings are not as shown. Refer to Chapter 4 – Part Replacement Procedures, Power Modules.
- 9. If one or more Power Modules is replaced, test the Gate Driver Board. Refer to Testing the Gate Driver Board in this chapter.
- 10. Assemble the drive in reverse order of disassembly.



**ATTENTION:** Replace all guards before applying power to the drive. Failure to replace guards may result in death or serious injury.

## Test 4 Testing the Bus Capacitors

The Bus Capacitor Bank is located on the left side of the Main Chassis.

**Figure 3.4**  
Bus Capacitor Bank Test

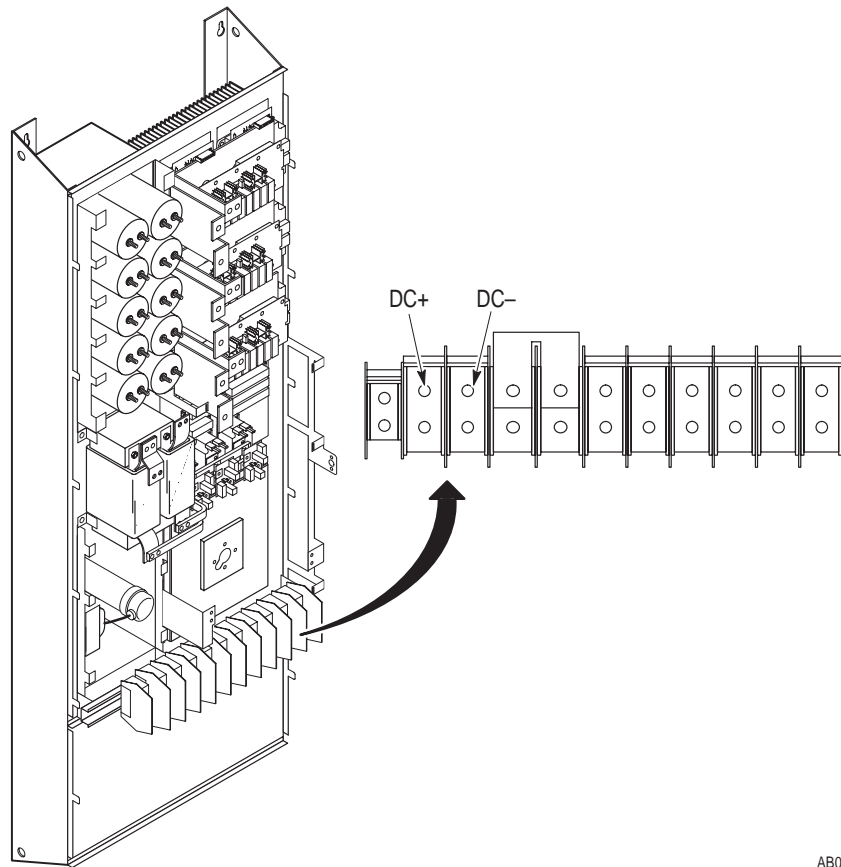

AB0453B



**ATTENTION:** Disconnect and lock out power from the drive before disassembling the drive. Failure to disconnect power may result in death or serious injury. Verify bus voltage by measuring the voltage between +DC and -DC on Terminal Block TB1. Do not attempt to service the drive until the bus voltage has discharged to zero volts.

**Important:** Before you remove connections and wires from the drive components, mark the connections and wires to correspond with their component connections and terminals to prevent incorrect wiring during assembly.

1. Remove power from the drive.
2. Check for zero volts at TB1 terminals +DC and –DC.
3. Check for absence of control voltage at:
  - TB20 and TB21 on drives using a PLC Comm Adapter Board
  - TB5, TB6, and TB7 on drives using a Standard Adapter Board
4. Set your meter to test voltage.
5. Connect the negative (–) lead of your meter to the (–) DC Bus terminal on TB1 and the positive (+) lead to the (+) DC Bus terminal. Refer to the following tables and former illustration for meter readings and terminal locations.



**ATTENTION:** Servicing energized industrial control equipment can be hazardous. Electrical shock, burns, or unintentional actuation of controlled industrial equipment may cause death or serious injury. Follow the safety-related practices of NFPA 70E, Electrical Safety for Employee Workplaces, when working on or near energized equipment. Do not work alone on energized equipment.

6. Apply power **AFTER** the meter is connected, otherwise your meter will read zero volts. Expand readings for all input voltage ratings.

**Table 3.C**  
**Bus Capacitor Bank Test**

Drive Rating	Input Volts	Meter Reading
A	200	280V DC +/-10%
	230	322V DC +/-10%
	240	336V DC +/-10%
B	380	535V DC +/-10%
	415	580V DC +/-10%
	480	650V DC +/-10%
C	500	700V DC +/-10%
	575	800V DC +/-10%
	600	850V DC +/-10%

7. If the voltage is out of tolerance, check the following:
  - An open condition at an Input Rectifier.
  - A voltage drop due to Bus Inductor L1 resistance.
  - A voltage drop between an Input Rectifier and the bus capacitors due to loose or resistive wires or connections.
  - Precharge circuit problems.
8. If the above check does not reveal a problem, replace the Bus Capacitor Bank and Load-Sharing Resistors. Refer to Chapter 4 – Part Replacement Procedures, Bus Capacitor Bank.



**ATTENTION:** Replace all guards before applying power to the drive. Failure to replace guards may result in death or serious injury.

---



### Test 5 Testing the Input Rectifiers

The Input Rectifiers are located on the bottom of the heat sink.

Figure 3.5  
Input Rectifier Test

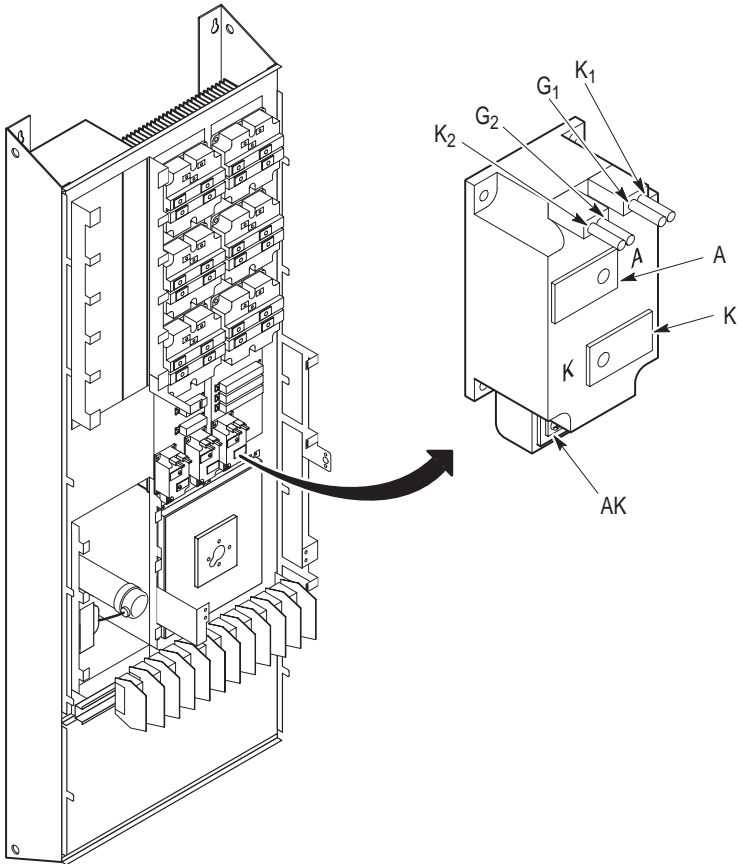

AB0454B



**ATTENTION:** Disconnect and lock out power from the drive before disassembling the drive. Failure to disconnect power may result in death or serious injury. Verify bus voltage by measuring the voltage between +DC and -DC on Terminal Block TB1. Do not attempt to service the drive until the bus voltage has discharged to zero volts.

**Important:** Before you remove connections and wires from the drive components, mark the connections and wires to correspond with their component connections and terminals to prevent incorrect wiring during assembly.

1. Remove power from the drive.
2. Check for zero volts at TB1 terminals +DC and –DC.
3. Check for absence of control voltage at:
  - TB20 and TB21 on drives using a PLC Comm Adapter Board
  - TB5, TB6, and TB7 on drives using a Standard Adapter Board
4. Remove the Gate Driver/Precharge Board Mounting Plate. Refer to Chapter 2 – Disassembly and Access Procedures, Removing the Gate Driver Board Mounting Plate.
5. Remove the Input Rectifier Snubber Board. Refer to Chapter 2 – Disassembly and Access Procedures, Removing the Input Rectifier Snubber Board.
6. Set your meter to test diodes.
7. The following table shows meter connections and ideal meter readings for those connections. Refer to the former illustration for meter connection locations.

**Table 3.D**  
**Input Rectifier Test**

Meter (+) Lead	Meter (–) Lead	Nominal Meter Reading
AK	K	Infinite
AK	A	Infinite
K	A	Infinite
K	AK	Infinite
A	AK	Infinite
A	K	Infinite
G1	K1	0.011
K1	G1	0.011
G2	K2	0.011
K2	G2	0.011

8. Replace the Input Rectifier if any meter readings are not as shown. Refer to Chapter 4 – Part Replacement Procedures, Input Rectifiers.
9. If the Input Rectifier shorted, check the Power Modules for damage. Refer to Testing the Power Modules in this chapter.

## Part Replacement Procedures

### Chapter Objective

This chapter describes procedures required to replace drive components. This chapter references Chapter 2 – Disassembly and Access Procedures for basic drive component access.

### Part Replacement Overview

The part replacement procedures in this chapter assume that the drive you are servicing either has no enclosure or that the enclosure is open. For more information on opening the Drive Enclosure, refer to Chapter 2 – Disassembly and Access Procedures, Opening the Drive Enclosure.

### Safety Precautions



**ATTENTION:** Some printed circuit boards and drive components may contain hazardous voltage levels. Remove power before you disconnect or reconnect wires, and before you remove or replace fuses and circuit boards. Verify bus voltage by measuring the voltage between +DC and –DC on Terminal Block TB1. Do not attempt to service the drive until the bus voltage has discharged to zero volts.

---

### Electrostatic Discharge Precautions



**ATTENTION:** This assembly contains parts and sub-assemblies that are sensitive to electrostatic discharge. Static control precautions are required when servicing this assembly. Component damage may result if you ignore electrostatic discharge control procedures. If you are not familiar with static control procedures, reference Allen-Bradley Publication 8000–4.5.2, Guarding Against Electrostatic Discharge, or any other applicable ESD protection handbook.

---

Electrostatic discharge generated by static electricity can damage the complimentary metallic oxide semiconductor devices on various drive boards. It is recommended that you perform these procedures to guard against this type of damage when circuit boards are removed or installed:

- Wear a wrist-type grounding strap that is grounded to the chassis.
- Attach the wrist strap before removing the new circuit board from the conductive packet.
- Remove boards from the drive and immediately insert them into their conductive packets.

### Tools

You need the following tools to disassemble and assemble the drive:

- Pliers
- Phillips screwdrivers (small, medium, and large)
- Standard screwdrivers (small, medium, and large)
- 25/64-inch or 10 mm socket
- 7/16-inch or 11 mm socket
- 33/64-inch or 13 mm deep-well socket
- 5/16-inch or 8 mm open-end wrench
- Torque wrench, metered in lb-in. or N-m
- Nylon tie wraps

## Major Component Replacement

This section explains in detail how to replace the following drive components:

- Bus Capacitor Bank
- Thermistor
- Power Modules
- Input Rectifiers
- Fan and Transformer Assembly
- DC Bus Inductor L1
- Ground Sense CT
- Bus Fuse F1
- LEMs
- MOV Surge Suppressor

For Gate Driver Board, Main Control Board, PLC Comm Adapter Board, Standard Adapter Board, Snubber Boards, and Control Interface Board installation and removal procedures, refer to Chapter 2.

# Detailed Product Identification

Allen-Bradley Adjustable Frequency AC Drives are modular by design to enhance troubleshooting and spare parts replacement, thereby helping reduce production down-time.

The following illustration calls out the main components of a typical drive. Component designs vary slightly among the different drive ratings, but component locations are identical.

**Figure 4.1**  
**Main Drive Components**

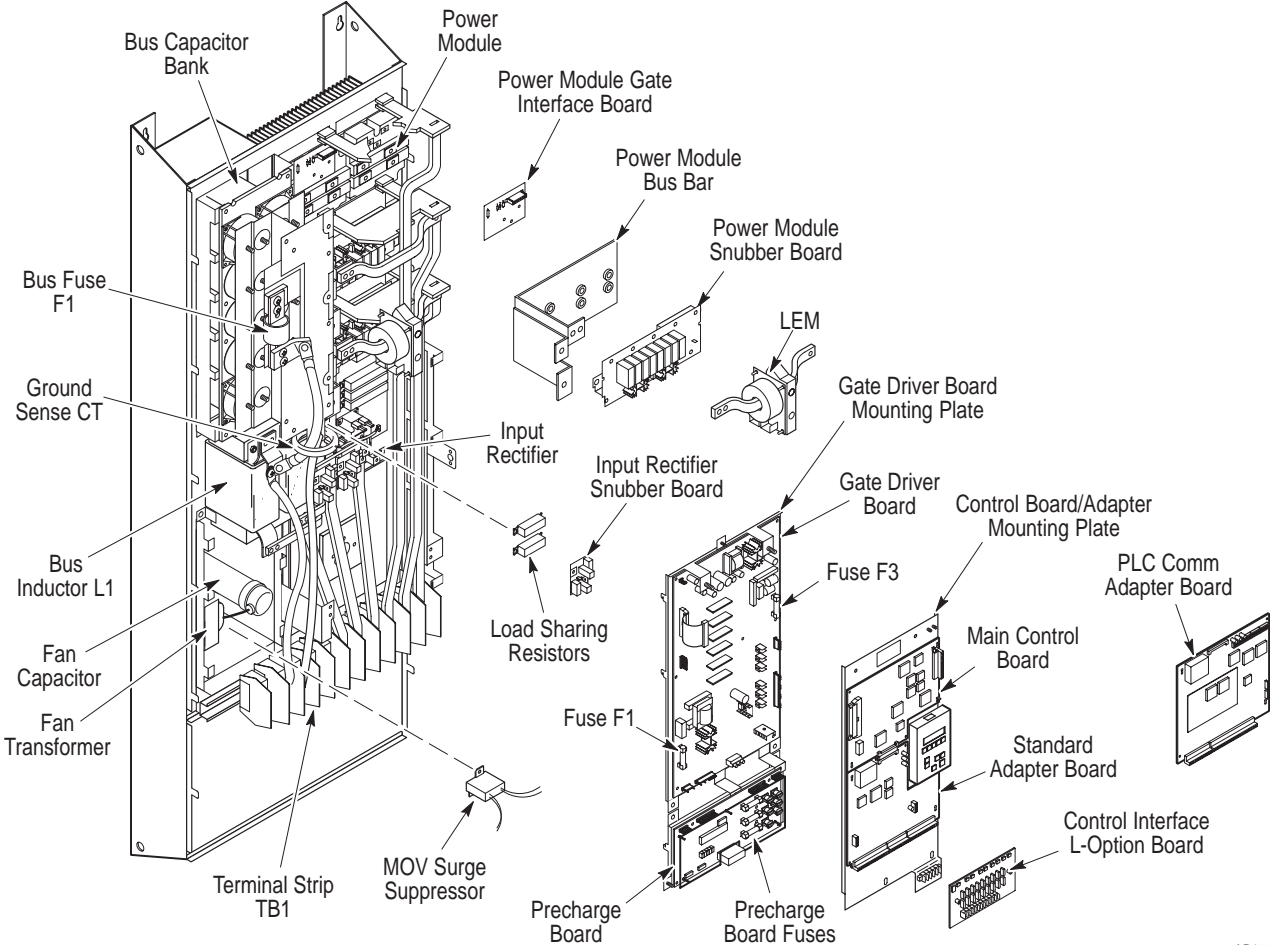

AB0575A

## Bus Capacitor Bank

The Bus Capacitor Bank is located on the left side of the Main Chassis.

**Figure 4.2**  
Bus Capacitor Bank

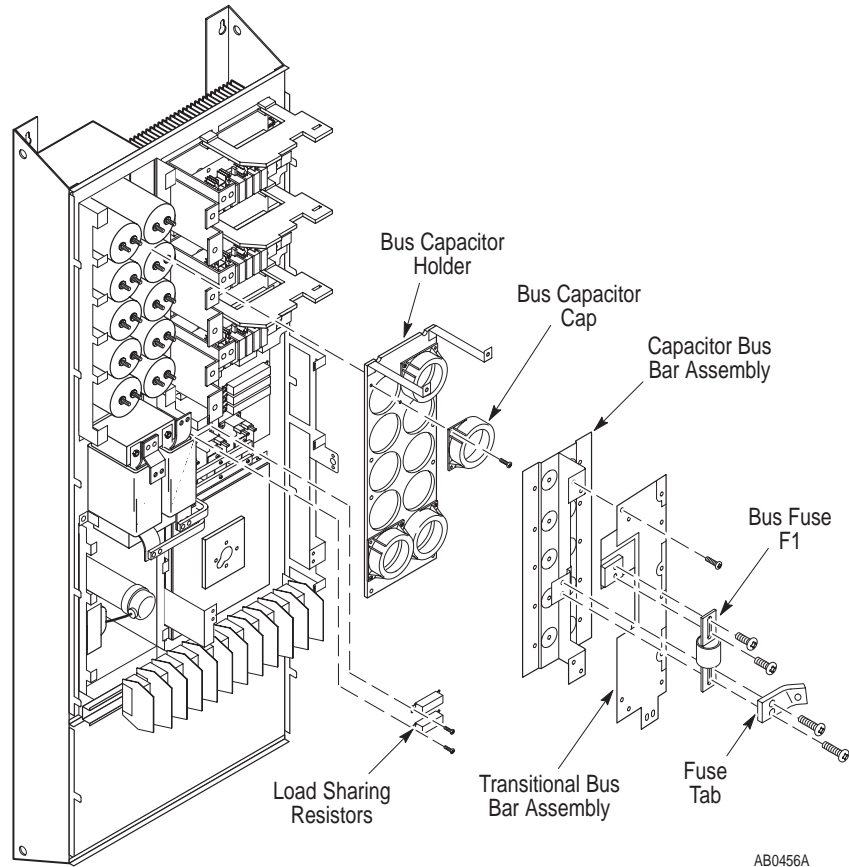

### Removal



**ATTENTION:** Disconnect and lock out power from the drive before disassembling the drive. Failure to disconnect power may result in death or serious injury. Verify bus voltage by measuring the voltage between +DC and -DC on Terminal Block TB1. Do not attempt to service the drive until the bus voltage has discharged to zero volts.



**ATTENTION:** Wear a wrist-type grounding strap when servicing 1336 FORCE Drives. Failure to protect drive components against ESD may damage drive components. Refer to Electrostatic Discharge Precautions at the beginning of this chapter.

**Important:** Before you remove connections and wires from the drive components, mark the connections and wires to correspond with their component connections and terminals to prevent incorrect wiring during assembly.

Access the Main Chassis:

1. Remove power from the drive.
2. Check for zero volts at TB1 terminals +DC and –DC.
3. Check for absence of control voltage at:
  - TB20 and TB21 on drives using a PLC Comm Adapter Board
  - TB5, TB6, and TB7 on drives using a Standard Adapter Board
4. Remove the High Voltage Guard from the drive. Refer to Chapter 2 – Disassembly and Access Procedures, Removing the High Voltage Guard.
5. Remove the Control Board/Adapter Mounting Plate. Refer to Chapter 2 – Disassembly and Access Procedures, Removing the Control Board/Adapter Mounting Plate.
6. Remove the Gate Driver Board Mounting Plate. Refer to Chapter 2 – Disassembly and Access Procedures, Removing the Gate Driver Board Mounting Plate.
7. Remove the Precharge Board Mounting Plate. Refer to Chapter 2 – Disassembly and Access Procedures, Removing the Precharge Board Mounting Plate.

Access the Bus Capacitor Bank:

1. Remove the screws fastening the Transitional Bus Bar Assembly to the Power Module Bus Bars, DC Bus Inductor, and Capacitor Bus Bar Assembly.
2. Remove the Bus Fuse. Refer to Bus Fuse F1 in this chapter.
3. Slide the Transitional Bus Bar Assembly to the left to remove it from the drive.
4. Remove the screws fastening the wires to the Capacitor Bus Bar Assembly.
5. Remove the nuts fastening the Capacitor Bus Bar Assembly to the Bus Capacitors.

6. Remove the Capacitor Bus Bar Assembly from the drive.
7. Remove the screws fastening the Bus Capacitor Holder to the chassis. Remove the Capacitor Holder and the two Cover Support Brackets at the top of the Bus Capacitor Holder from the drive.
8. Remove the Bus Capacitors from the Drive.

### Installation

1. Fasten the capacitor assembly in reverse order of removal. Refer to Chapter 2 – Disassembly and Access Procedures, Fastener Torque Specifications.

**Important:** Orient the notch and vent hole on the Bus Capacitors to the top of the drive.

2. Connect the Load-Sharing Resistors to the Bus Capacitors according to the following diagram. Refer to the schematic diagrams in this manual for more information on component configurations.

**Important:** Check the Load-Sharing Resistors for an open condition and replace any open resistors. Resistors must measure within 20 percent tolerance of their marked resistance value.

**Important:** If the drive is equipped with PEM nuts on the Cap Bus bar, use them instead of capacitor studs to make the electrical connection.

**Figure 4.3**  
Load-Sharing Resistor Connections to Bus Capacitors

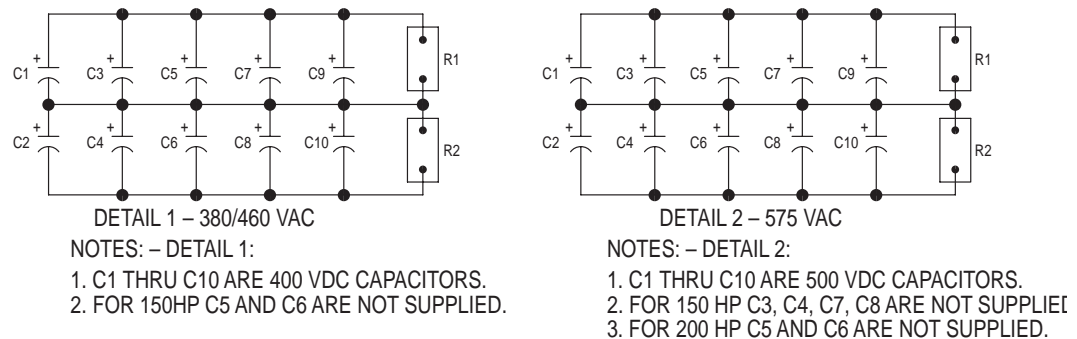

AB0752A



**ATTENTION:** Capacitors not installed correctly will explode or vent and could cause injury and equipment damage. Observe correct polarities.



## Thermistor

The Thermistor is located on the heat sink at the top-middle of the drive.

Figure 4.4  
Thermistor

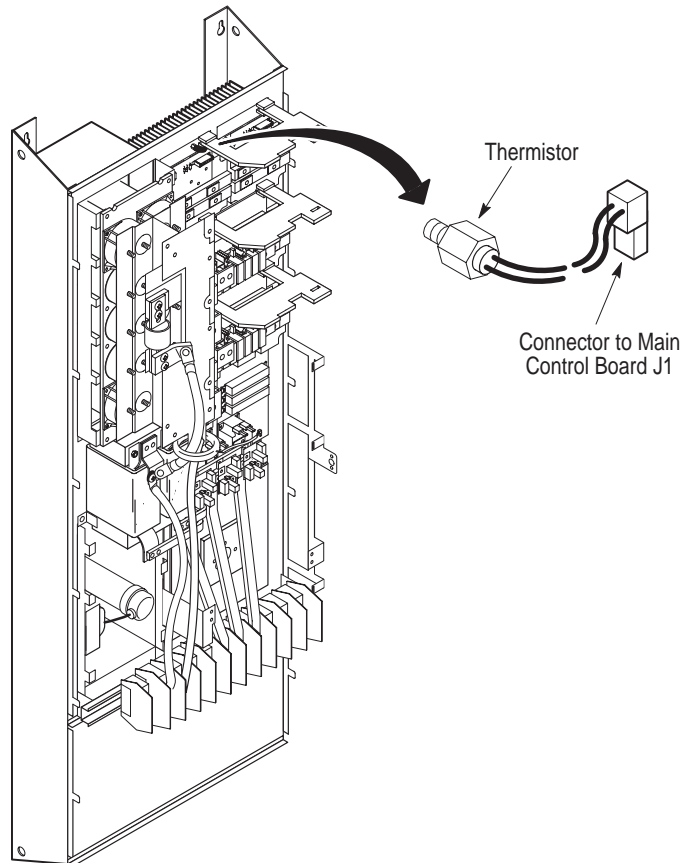

AB0458A

## Removal



**ATTENTION:** Disconnect and lock out power from the drive before disassembling the drive. Failure to disconnect power may result in death or serious injury. Verify bus voltage by measuring the voltage between +DC and -DC on Terminal Block TB1. Do not attempt to service the drive until the bus voltage has discharged to zero volts.



**ATTENTION:** Wear a wrist-type grounding strap when servicing 1336 FORCE Drives. Failure to protect drive components against ESD may damage drive components. Refer to Electrostatic Discharge Precautions at the beginning of this chapter.

---

**Important:** Before you remove connections and wires from the drive components, mark the connections and wires to correspond with their component connections and terminals to prevent incorrect wiring during assembly.

1. Remove power from the drive.
2. Check for zero volts at TB1 terminals +DC and -DC.
3. Check for absence of control voltage at:
  - TB20 and TB21 on drives using a PLC Comm Adapter Board
  - TB5, TB6, and TB7 on drives using a Standard Adapter Board
4. Remove the screws fastening the High Voltage Guard to the drive. Refer to Chapter 2 – Disassembly and Access Procedures, Removing the High Voltage Guard.
5. Disconnect the Thermistor connector at J1 on the Main Control Board.
6. Unscrew the Thermistor from the heat sink.

### Installation

Install the Thermistor in reverse order of removal. Refer to Chapter 2 – Disassembly and Access Procedures, Fastener Torque Specifications.



**ATTENTION:** Replace all guards before applying power to the drive. Failure to replace guards may result in death or serious injury.

---

## Power Modules

The Power Modules are located near the top of the heat sink. If one or more Power Modules is replaced, you must check the Power Module Snubber Board and the Precharge Board. Refer to Chapter 2 – Disassembly and Access Procedures, Removing the Precharge Board Mounting Plate.

**Figure 4.5**  
Power Modules

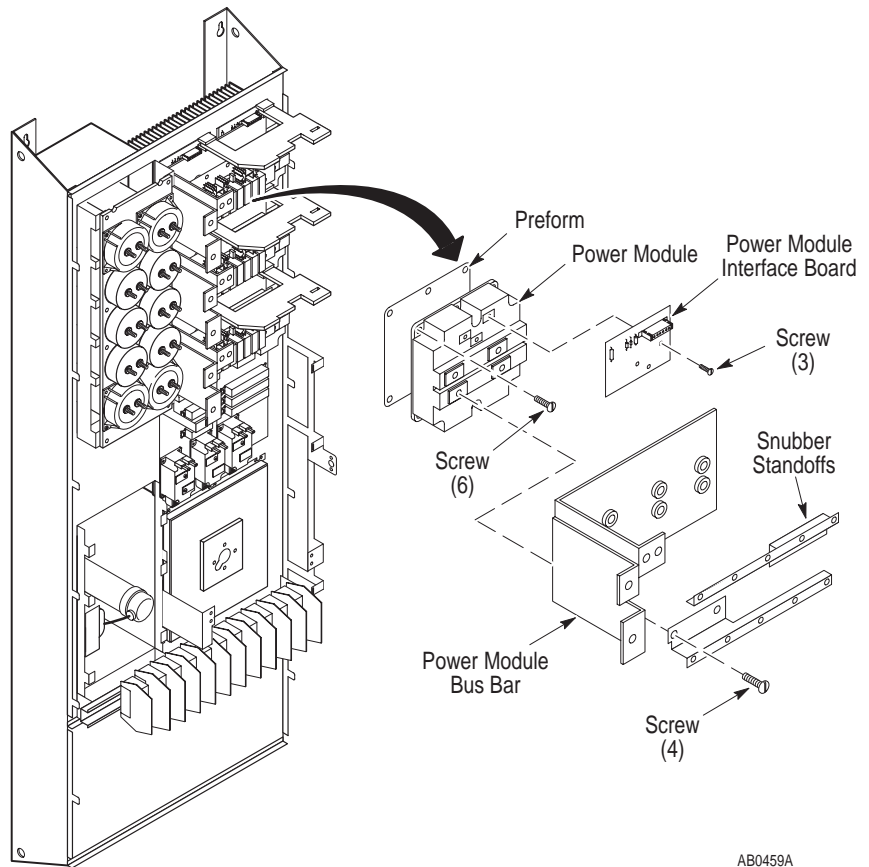

AB0459A

## Removal



**ATTENTION:** Disconnect and lock out power from the drive before disassembling the drive. Failure to disconnect power may result in death or serious injury. Verify bus voltage by measuring the voltage between +DC and -DC on Terminal Block TB1. Do not attempt to service the drive until the bus voltage has discharged to zero volts.



**ATTENTION:** Hazard of electric shock exists. Up to 1,600 VDC will be on J1 if the Snubber Resistor is open. Measure for zero VDC from Snubber Board terminal TP3 to plus (+) bus before removing connector J1. Use a resistor greater than 1 ohm and less than 100 ohm, rated for 25 watts minimum, between TP3 and plus (+) bus to discharge any voltage. Refer to Chapter 2 – Disassembly and Access Procedures, Removing a Power Module Snubber Board.

---



**ATTENTION:** Wear a wrist-type grounding strap when servicing 1336 FORCE Drives. Failure to protect drive components against ESD may damage drive components. Refer to Electrostatic Discharge Precautions at the beginning of this chapter.

---

**Important:** Before you remove connections and wires from the drive components, mark the connections and wires to correspond with their component connections and terminals to prevent incorrect wiring during assembly.

Access the Power Module:

1. Remove power from the drive.
2. Check for zero volts at TB1 terminals +DC and –DC.
3. Check for absence of control voltage at:
  - TB20 and TB21 on drives using a PLC Comm Adapter Board
  - TB5, TB6, and TB7 on drives using a Standard Adapter Board
4. Remove the High Voltage Guard from the drive. Refer to Chapter 2 – Disassembly and Access Procedures, Removing the High Voltage Guard.
5. Remove the Control Board/Adapter Mounting Plate. Refer to Chapter 2 – Disassembly and Access Procedures, Removing the Control Board/Adapter Mounting Plate.
6. Remove the Gate Driver Board Mounting Plate. Refer to Chapter 2 – Disassembly and Access Procedures, Removing the Gate Driver Board Mounting Plate.
7. Remove the Precharge Board Mounting Plates. Refer to Chapter 2 – Disassembly and Access Procedures, Removing the Precharge Board Mounting Plate.

---

### Remove the Power Module:

1. Remove the Power Module Snubber Boards. Refer to Chapter 2 – Disassembly and Access Procedures, Removing a Power Module Snubber Board.
2. Remove the screws fastening the Snubber standoffs to the Power Module Bus Bar to remove the standoffs.
3. Remove the screws fastening the Power Module Bus Bar to the Power Modules and the Transitional Bus Bar assembly.
4. Slide the Power Module Bus Bar toward the right side of the drive to remove.
5. Remove the wiring harness from Power Module Gate Interface Board Connector J1.
6. Remove the screws fastening the Power Module Gate Interface Boards to the Power Modules.
7. Remove the Power Module Gate Interface Boards.
8. Remove the screws fastening the Power Modules to the heat sink.

### Installation

1. Clean all surfaces between the Power Module and the heat sink using a soft, clean cloth.
2. Replace the Preform between the Power Module and the heat sink.
3. Install the Power Module in reverse order of removal. Refer to Chapter 2 – Disassembly and Access Procedures, Fastener Torque Specifications.



**ATTENTION:** Do not substitute longer or shorter hardware when fastening the Power Module components to the Power Modules. Use the same size fastener to fasten the components as was originally used. Using different fastener lengths will damage the Power Modules.

---



**ATTENTION:** Replace all guards before applying power to the drive. Failure to replace guards may result in death or serious injury.

---

## Input Rectifiers

The Input Rectifiers are located toward the bottom of the heat sink.

**Figure 4.6**  
Input Rectifiers

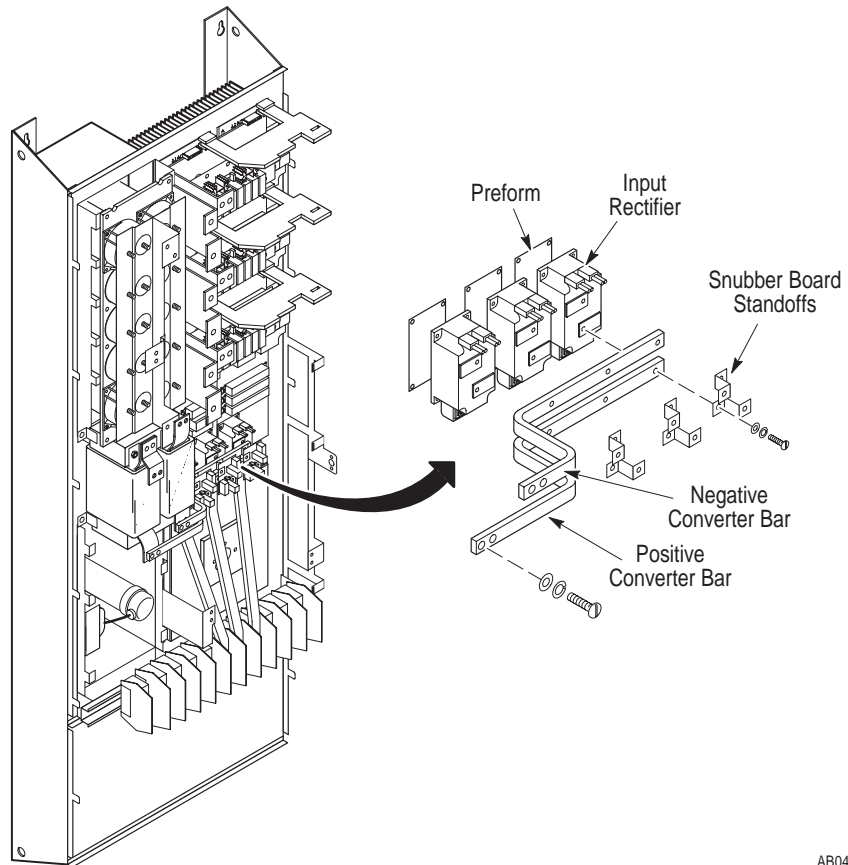

AB0460A

### Removal



**ATTENTION:** Disconnect and lock out power from the drive before disassembling the drive. Failure to disconnect power may result in death or serious injury. Verify bus voltage by measuring the voltage between +DC and -DC on Terminal Block TB1. Do not attempt to service the drive until the bus voltage has discharged to zero volts.



**ATTENTION:** Wear a wrist-type grounding strap when servicing 1336 FORCE Drives. Failure to protect drive components against ESD may damage drive components. Refer to Electrostatic Discharge Precautions at the beginning of this chapter.

**Important:** Before you remove connections and wires from the drive components, mark the connections and wires to correspond with their component connections and terminals to prevent incorrect wiring during assembly.

Access the Input Rectifiers:

1. Remove power from the drive.
2. Check for zero volts at TB1 terminals +DC and –DC.
3. Check for absence of control voltage at:
  - TB20 and TB21 on drives using a PLC Comm Adapter Board
  - TB5, TB6, and TB7 on drives using a Standard Adapter Board
4. Remove the High Voltage Guard from the drive. Refer to Chapter 2 – Disassembly and Access Procedures, Removing the High Voltage Guard.
5. Remove the Control Board/Adapter Mounting Plate. Refer to Chapter 2 – Disassembly and Access Procedures, Removing the Control Board/Adapter Mounting Plate.
6. Remove the Gate Driver Board Mounting Plate. Refer to Chapter 2 – Disassembly and Access Procedures, Removing the Gate Driver Board Mounting Plate.

Remove the Input Rectifiers:

1. Remove the Input Rectifier Snubber Boards. Refer to Chapter 2 – Disassembly and Access Procedures, Removing an Input Rectifier Snubber Board.
2. Remove the screws fastening the Input Rectifier standoffs to the rectifiers.
3. Remove the screws fastening the Positive and Negative Converter Bars to the DC Bus Inductor.
4. Remove the TB1 Input Bus Bars and the Precharge Board Wiring Harnesses from the Rectifiers.
5. Remove the screws fastening the Input Rectifiers to the heat sink.

### Installation

1. Clean all surfaces between the Input Rectifier and the heat sink using a soft, clean cloth.
2. Replace the Preform between the Input Rectifier and the heat sink.
3. Install the Input Rectifier in reverse order of removal. Refer to Chapter 2 – Disassembly and Access Procedures, Fastener Torque Specifications.

**Important:** Install washers on TB1 terminals with the serrated side facing toward you.



**ATTENTION:** Replace all guards before applying power to the drive. Failure to replace guards may result in death or serious injury.

## Fan and Transformer Assembly

The Fan is located in the chassis and under TB1 at the bottom of the heat sink. The Fan Transformer and Fan Capacitor are located in the bottom left corner of the chassis.

**Figure 4.7**  
Fan and Transformer

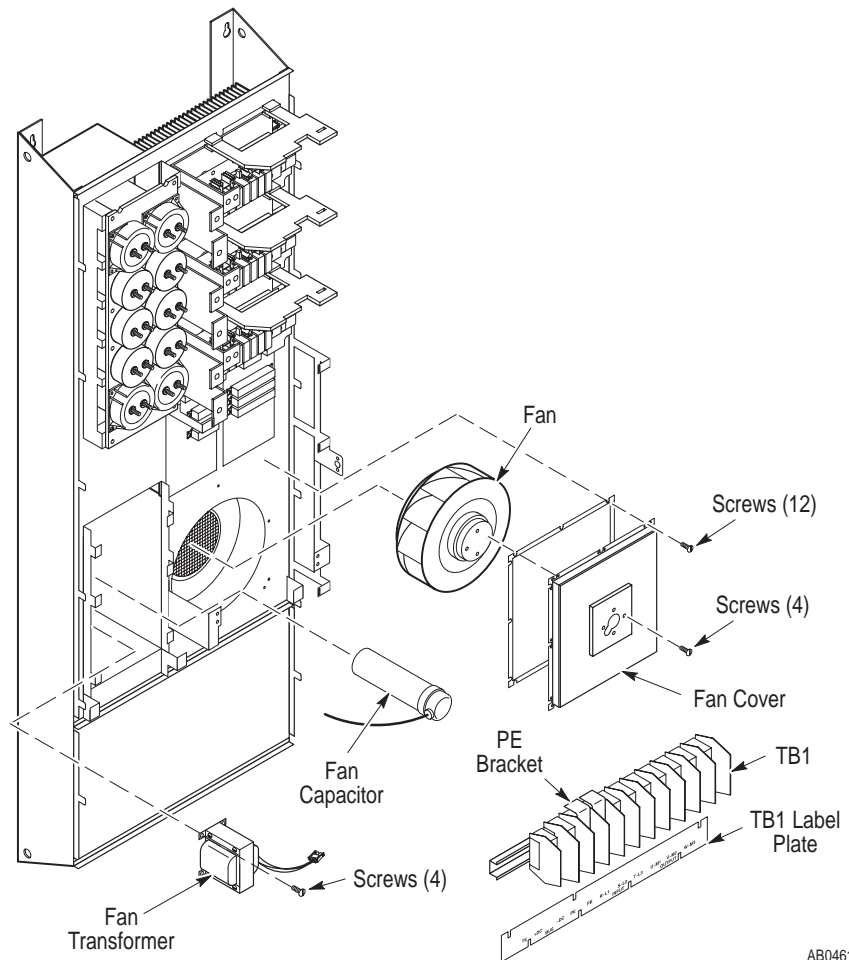

AB0461A



---

## Removal

---



**ATTENTION:** Disconnect and lock out power from the drive before disassembling the drive. Failure to disconnect power may result in death or serious injury. Verify bus voltage by measuring the voltage between +DC and –DC on Terminal Block TB1. Do not attempt to service the drive until the bus voltage has discharged to zero volts.

---



**ATTENTION:** Hazard of electric shock exists. Up to 1,600 VDC will be on J1 if the Snubber Resistor is open. Measure for zero VDC from Snubber Board terminal TP3 to plus (+) bus before removing connector J1. Use a resistor greater than 1 ohm and less than 100 ohm, rated for 25 watts minimum, between TP3 and plus (+) bus to discharge any voltage. Refer to Chapter 2 – Disassembly and Access Procedures, Removing a Power Module Snubber Board.

---



**ATTENTION:** Wear a wrist-type grounding strap when servicing 1336 FORCE Drives. Failure to protect drive components against ESD may damage drive components. Refer to Electrostatic Discharge Precautions at the beginning of this chapter.

---

**Important:** Before you remove connections and wires from the drive components, mark the connections and wires to correspond with their component connections and terminals to prevent incorrect wiring during assembly.

Access the Main Chassis:

1. Remove power from the drive.
2. Check for zero volts at TB1 terminals +DC and –DC.
3. Check for absence of control voltage at:
  - TB20 and TB21 on drives using a PLC Comm Adapter Board
  - TB5, TB6, and TB7 on drives using a Standard Adapter Board
4. Remove the High Voltage Guard from the drive. Refer to Chapter 2 – Disassembly and Access Procedures, Removing the High Voltage Guard.
5. Remove the Control Board/Adapter Mounting Plate. Refer to Chapter 2 – Disassembly and Access Procedures, Removing the Control Board/Adapter Mounting Plate.

6. Remove the Gate Driver Board Mounting Plate. Refer to Chapter 2– Disassembly and Access Procedures, Removing the Gate Driver Board Mounting Plate.
7. Remove the Precharge Board Mounting Plates. Refer to Chapter 2 – Disassembly and Access Procedures, Removing the Precharge Board Mounting Plate.
8. Remove the Motor Bus Bars. Refer to Chapter 2 – Disassembly and Access Procedures, Removing the Power Module Snubber Boards.
9. Remove all wires from PE, TE, MOV and Fan Transformer at TB1.
10. Remove the TB1 Input Bus Bars from the Input Rectifiers.
11. Remove the Bus PE Bracket from TB1 PE partitions.

Remove TB1 and Mounting Rail:

1. Loosen the screws on the Terminal End Stops on each end of the TB1 Mounting Rail.
2. Slide the left End Stop off the TB1 Mounting Rail.
3. Remove the screw fastening the left side of the Mounting Rail to the chassis.
4. Slide the right End Stop off the TB1 Mounting Rail.
5. Slide the first partition toward the right end of the rail.
6. Remove the screw fastening the right side of the Mounting Rail to the chassis.
7. Slide the two PE partitions apart and toward opposite ends of the TB1 Mounting Rail.
8. Remove the screw fastening the Mounting Rail to the chassis.
9. Remove the TB1 Mounting Rail and the Label Plate.

Remove the Fan:

1. Disconnect the Fan wiring harness.
2. Remove the screws fastening the Fan Cover to the chassis.
3. Pull the Fan Cover assembly away from the Drive.
4. Remove the screws fastening the Fan to the Fan Cover to remove the Fan.
5. Disconnect the Fan Capacitor from the Fan Wiring Harness.
6. Unscrew the Fan Capacitor from the chassis by hand.

7. Disconnect the Fan Transformer from the Fan Wiring Harness and from TB1.
8. Remove the screws fastening the Fan Transformer to the chassis.

### Installation

Install the Fan Assembly in reverse order of removal, with the following exceptions:

- Thread the Fan wiring connector through the hole in the Fan Cover.
- Refer to Chapter 2 – Disassembly and Access Procedures, Fastener Torque Specifications.
- Install the Fan Capacitor to the chassis with M8 split washer and hand tighten.
- Connect the Fan Transformer red wire to TB1 terminal S-L2 and the black wire to TB1 terminal R-L1.

**Important:** Install washers on TB1 terminals with the serrated side facing toward you.



**ATTENTION:** Replace all guards before applying power to the drive. Failure to replace guards may result in death or serious injury.

---

## DC Bus Inductor L1

DC Bus Inductor L1 is located on the lower left corner of the drive.

**Figure 4.8**  
DC Bus Inductor L1

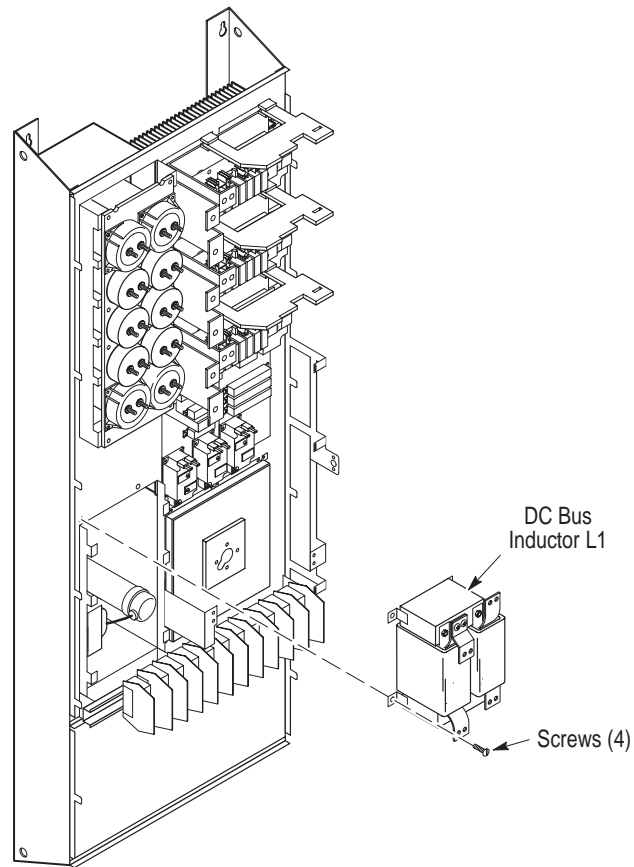

AB0462A

### Removal



**ATTENTION:** Disconnect and lock out power from the drive before disassembling the drive. Failure to disconnect power may result in death or serious injury. Verify bus voltage by measuring the voltage between +DC and -DC on Terminal Block TB1. Do not attempt to service the drive until the bus voltage has discharged to zero volts.



**ATTENTION:** Wear a wrist-type grounding strap when servicing 1336 FORCE Drives. Failure to protect drive components against ESD may damage drive components. Refer to Electrostatic Discharge Precautions at the beginning of this chapter.

**Important:** Before you remove connections and wires from the drive components, mark the connections and wires to correspond with their component connections and terminals to prevent incorrect wiring during assembly.

1. Remove power from the drive.
2. Check for zero volts at TB1 terminals +DC and –DC.
3. Check for absence of control voltage at:
  - TB20 and TB21 on drives using a PLC Comm Adapter Board
  - TB5, TB6, and TB7 on drives using a Standard Adapter Board
4. Remove the High Voltage Guard from the drive. Refer to Chapter 2 – Disassembly and Access Procedures, Removing the High Voltage Guard.
5. Remove the Gate Driver Board Mounting Plate. Refer to Chapter 2 – Disassembly and Access Procedures, Removing the Gate Driver Board Mounting Plate.
6. Remove the Fuse and TB1 cables from the DC Bus Inductor.
7. Remove the screws fastening the DC Bus Inductor to the Transitional Bus Bar Assembly.
8. Remove the Positive and Negative Converter Bars. Refer to Input Rectifiers in this chapter.
9. Remove the screws fastening the Bus Bar Cable Adapters to the DC Bus Inductor terminals.
10. Remove screws fastening the DC Bus Inductor to the chassis.



**ATTENTION:** The DC Bus Inductor is heavy and may fall during disassembly. A falling inductor may result in death or serious injury.

---

**Important:** Note the position and orientation of the Ground Sense CT (CT3) around the (–)Bus terminal at the top of the Bus inductor. This CT will come off when the inductor is removed. Re-install the CT in the same position, and make sure the (+)Bus cable to the fuse passes through the Ground Sense CT during assembly.

11. Remove the Bus Inductor from the Drive.

### Installation

Install DC Bus Inductor L1 in reverse order of removal. Refer to Chapter 2 – Disassembly and Access Procedures, Fastener Torque Specifications.



**ATTENTION:** Replace all guards before applying power to the drive. Failure to replace guards may result in death or serious injury.

### Ground Sense CT

The Ground Sense CT is located between DC Bus Inductor L1 and the Transitional Bus Bar Assembly.

**Figure 4.9**  
Ground Sense CT

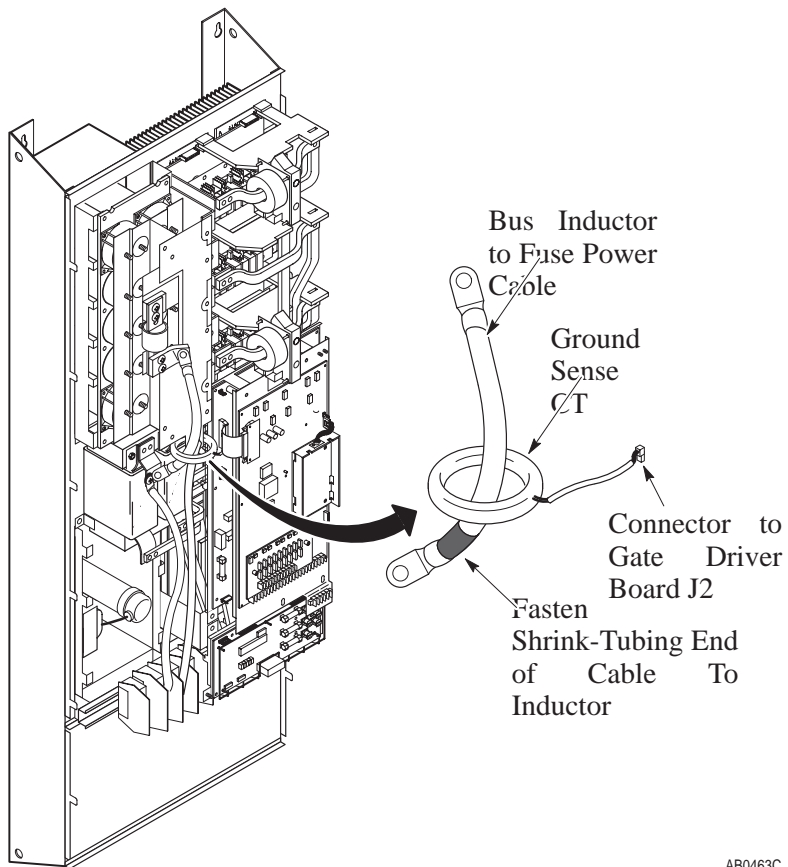

AB0463C

### Removal



**ATTENTION:** Disconnect and lock out power from the drive before disassembling the drive. Failure to disconnect power may result in death or serious injury. Verify bus voltage by measuring the voltage between +DC and -DC on Terminal Block TB1. Do not attempt to service the drive until the bus voltage has discharged to zero volts.



**ATTENTION:** Wear a wrist-type grounding strap when servicing 1336 FORCE Drives. Failure to protect drive components against ESD may damage drive components. Refer to Electrostatic Discharge Precautions at the beginning of this chapter.

**Important:** Before you remove connections and wires from the drive components, mark the connections and wires to correspond with their component connections and terminals to prevent incorrect wiring during assembly.

1. Remove power from the drive.
2. Check for zero volts at TB1 terminals +DC and –DC.
3. Check for absence of control voltage at:
  - TB20 and TB21 on drives using a PLC Comm Adapter Board
  - TB5, TB6, and TB7 on drives using a Standard Adapter Board
4. Remove the High Voltage Guard from the drive. Refer to Chapter 2 – Disassembly and Access Procedures, Removing the High Voltage Guard.
5. Disconnect the Ground Sense CT from Gate Driver Board connector J2.
6. Remove the screws from the wire passing through Ground Sense CT. One screw is located at Bus Fuse F1, and one at the DC Bus Inductor.
7. Remove the screws fastening the bottom of Bus Fuse F1 to the Capacitor Bus Bar Assembly.
8. Remove the screws fastening the Transitional Bus Bar Assembly to the Power Module Bus Bars, DC Bus Inductor, and Capacitor Bus Bar Assembly.
9. Slide the Transitional Bus Bar Assembly to the left to remove it from the Drive.

### Installation

Install the Ground Sense CT in reverse order of removal, inserting the wire, connecting Bus Fuse F1 to DC Bus Inductor, through the center of the Ground Sense CT. Refer to Chapter 2 – Disassembly and Access Procedures, Fastener Torque Specifications.



**ATTENTION:** A possible short-circuit hazard exists. Position the fuse-to-inductor wire with the shrink-wrapped end of the wire connected to the Bus Inductor. Failure to position the wire as illustrated may result in serious injury or equipment damage.



**ATTENTION:** Replace all guards before applying power to the drive. Failure to replace guards may result in death or serious injury.

### Bus Fuse F1

The Bus Fuse is located on the Transitional Bus Bar Assembly.

**Figure 4.10**  
Bus Fuse F1

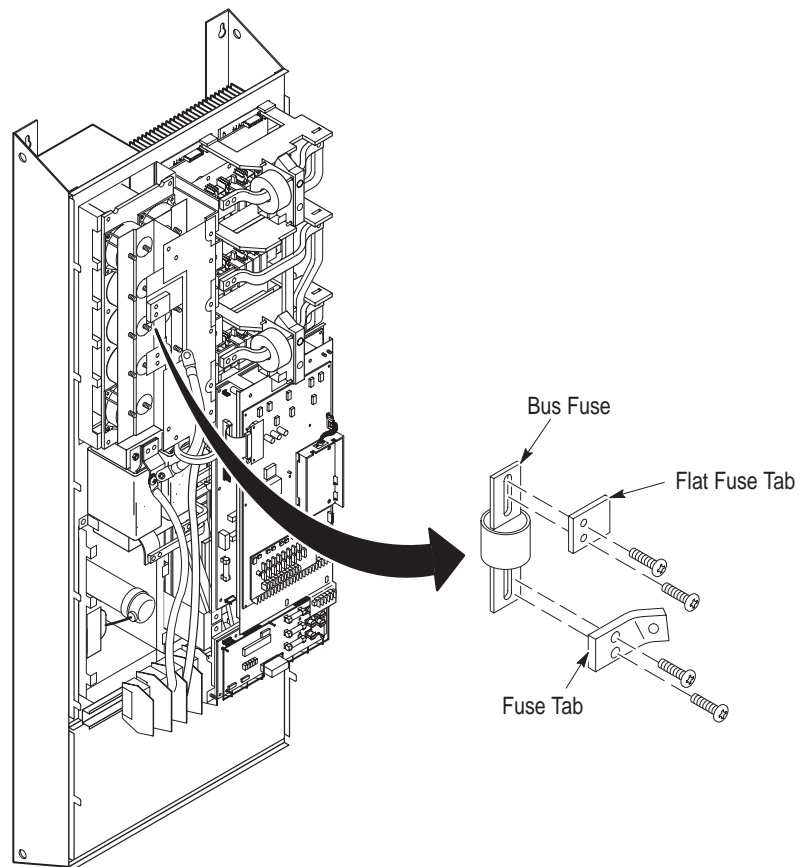

AB0464B



---

## Removal

---



**ATTENTION:** Disconnect and lock out power from the drive before disassembling the drive. Failure to disconnect power may result in death or serious injury. Verify bus voltage by measuring the voltage between +DC and –DC on Terminal Block TB1. Do not attempt to service the drive until the bus voltage has discharged to zero volts.

---



**ATTENTION:** Wear a wrist-type grounding strap when servicing 1336 FORCE Drives. Failure to protect drive components against ESD may damage drive components. Refer to Electrostatic Discharge Precautions at the beginning of this chapter.

---

**Important:** Before you remove connections and wires from the drive components, mark the connections and wires to correspond with their component connections and terminals to prevent incorrect wiring during assembly.

1. Remove power from the drive.
2. Check for zero volts at TB1 terminals +DC and –DC.
3. Check for absence of control voltage at:
  - TB20 and TB21 on drives using a PLC Comm Adapter Board
  - TB5, TB6, and TB7 on drives using a Standard Adapter Board
4. Remove the High Voltage Guard from the drive. Refer to Chapter 2 – Disassembly and Access Procedures, Removing the High Voltage Guard.
5. Remove the screws fastening the Bus Fuse to the drive.

## Installation

Install the Bus Fuse in reverse order of removal. Refer to Chapter 2 – Disassembly and Access Procedures, Fastener Torque Specifications.



**ATTENTION:** Replace all guards before applying power to the drive. Failure to replace guards may result in death or serious injury.

---

## LEMs

Figure 4.11  
LEMs

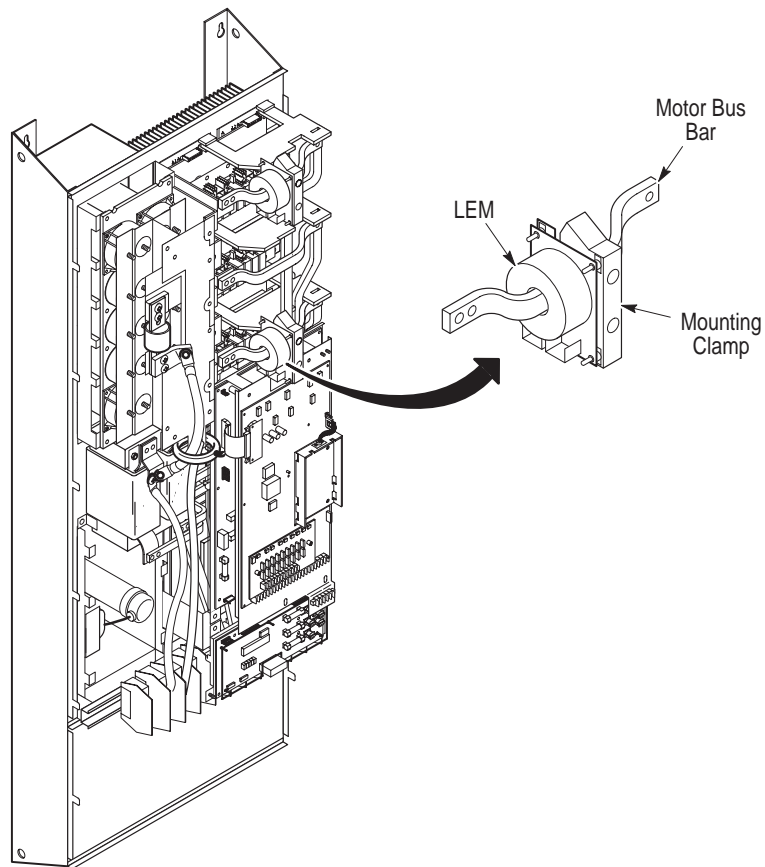

AB0465A

## Removal



**ATTENTION:** Disconnect and lock out power from the drive before disassembling the drive. Failure to disconnect power may result in death or serious injury. Verify bus voltage by measuring the voltage between +DC and -DC on Terminal Block TB1. Do not attempt to service the drive until the bus voltage has discharged to zero volts.



**ATTENTION:** Hazard of electric shock exists. Up to 1,600 VDC will be on J1 if the Snubber Resistor is open. Measure for zero VDC from Snubber Board terminal TP3 to plus (+) bus before removing connector J1. Use a resistor greater than 1 ohm and less than 100 ohm, rated for 25 watts minimum, between TP3 and plus (+) bus to discharge any voltage. Refer to Chapter 2 – Disassembly and Access Procedures, Removing a Power Module Snubber Board.

---



**ATTENTION:** Wear a wrist-type grounding strap when servicing 1336 FORCE Drives. Failure to protect drive components against ESD may damage drive components. Refer to Electrostatic Discharge Precautions at the beginning of this chapter.

---

**Important:** Before you remove connections and wires from the drive components, mark the connections and wires to correspond with their component connections and terminals to prevent incorrect wiring during assembly.

1. Remove power from the drive.
2. Check for zero volts at TB1 terminals +DC and –DC.
3. Check for absence of control voltage at:
  - TB20 and TB21 on drives using a PLC Comm Adapter Board
  - TB5, TB6, and TB7 on drives using a Standard Adapter Board
4. Remove the High Voltage Guard from the drive. Refer to Chapter 2 – Disassembly and Access Procedures, Removing the High Voltage Guard.
5. Remove the wires from the connectors on the LEMs.
6. Remove the screws fastening the LEM Motor Bus Bars to the Output Motor Bus Bars.
7. Remove the two screws and the clamping plate holding the LEM mounting clamp around the Motor Bus Bar.
8. Pull the LEMs away from the mounting plates.

### Installation

Install the LEMs in reverse order of removal. Refer to Chapter 2 – Disassembly and Access Procedures, Fastener Torque Specifications.



**ATTENTION:** Replace all guards before applying power to the drive. Failure to replace guards may result in death or serious injury.

### MOV Surge Suppressor

The MOV Surge Suppressor is located in the bottom-left corner of the Drive near the Fan Transformer and Fan Capacitor.

The MOV protects the drive from high voltage surges above approximately 1,000 volts. Replace it if it is burned, expanded, or ruptured after such events as a lightning strike or inadvertent connection of the drive input to a voltage source substantially above nameplate voltage.

**Figure 4.12**  
**MOV Surge Suppressor**

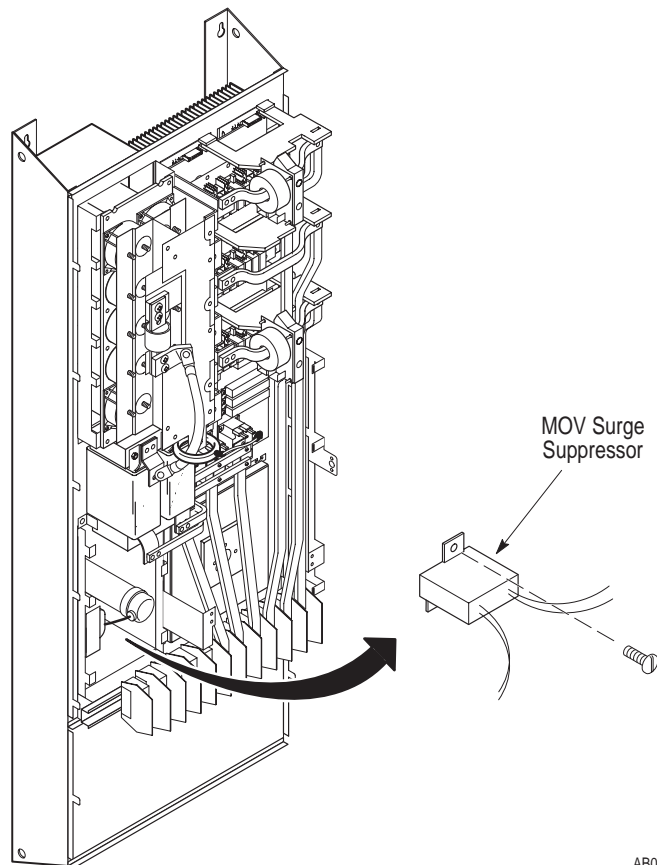

---

## Removal

---



**ATTENTION:** Wear a wrist-type grounding strap when servicing 1336 FORCE Drives. Failure to protect drive components against ESD may damage drive components. Refer to Electrostatic Discharge Precautions at the beginning of this chapter.

---

**Important:** Before you remove connections and wires from the drive components, mark the connections and wires to correspond with their component connections and terminals to prevent incorrect wiring during assembly.

1. Remove power from the drive.
2. Check for zero volts at TB1 terminals +DC and –DC.
3. Check for absence of control voltage at:
  - TB20 and TB21 on drives using a PLC Comm Adapter Board
  - TB5, TB6, and TB7 on drives using a Standard Adapter Board
4. Remove the nut fastening the MOV Surge Suppressor ground wire to the ground stud on the chassis.
5. Remove the MOV Surge Suppressor wires from TB1 terminals R-L1, S-L2, and T-L3.
6. Remove the screw fastening the MOV Surge Suppressor to the chassis.
7. Remove the MOV Surge Suppressor from the Drive.

## Installation

Install the MOV Surge Suppressor in reverse order of removal. Refer to Chapter 2 – Disassembly and Access Procedures, Fastener Torque Specifications.

**Important:** Install washers on TB1 terminals with the serrated side facing toward you.



**ATTENTION:** Replace all guards before applying power to the drive. Failure to replace guards may result in death or serious injury.

---

**This Page Intentionally Left Blank**

## Replacement Parts List

### Chapter Objectives

This chapter illustrates and lists replacement parts for the 1336 FORCE Drives rated B150 – B250 and C150 – C250 and describes replacement parts ordering procedures.

The following illustration and table show you parts, part names, locations, and chapters for replacement procedures.

### Ordering Replacement Parts

For your convenience, the Allen-Bradley Drives Division and the Allen-Bradley Support Division provide efficient and convenient repair and exchange for eligible equipment.

A product service report number is required to return any equipment for repair. Your local Allen-Bradley distributor or area sales and support office can provide you with a product service report number.

You should return equipment to be repaired to the area sales and support center nearest you. Reference the product service report number on the carton and packing slip. Include:

- Your company name
- Your company address
- The repair purchase order number
- A brief description of the problem

Contact your local Allen-Bradley distributor or sales office for a complete listing of area sales and support centers near you.

For parts catalog numbers, refer to the 1336 FORCE Spare Parts Pricing publication included with your drive documentation set.

# Replacement Parts Listing

**Figure 5.1**  
Parts for B150 – B250 and C150 – C250 Drives

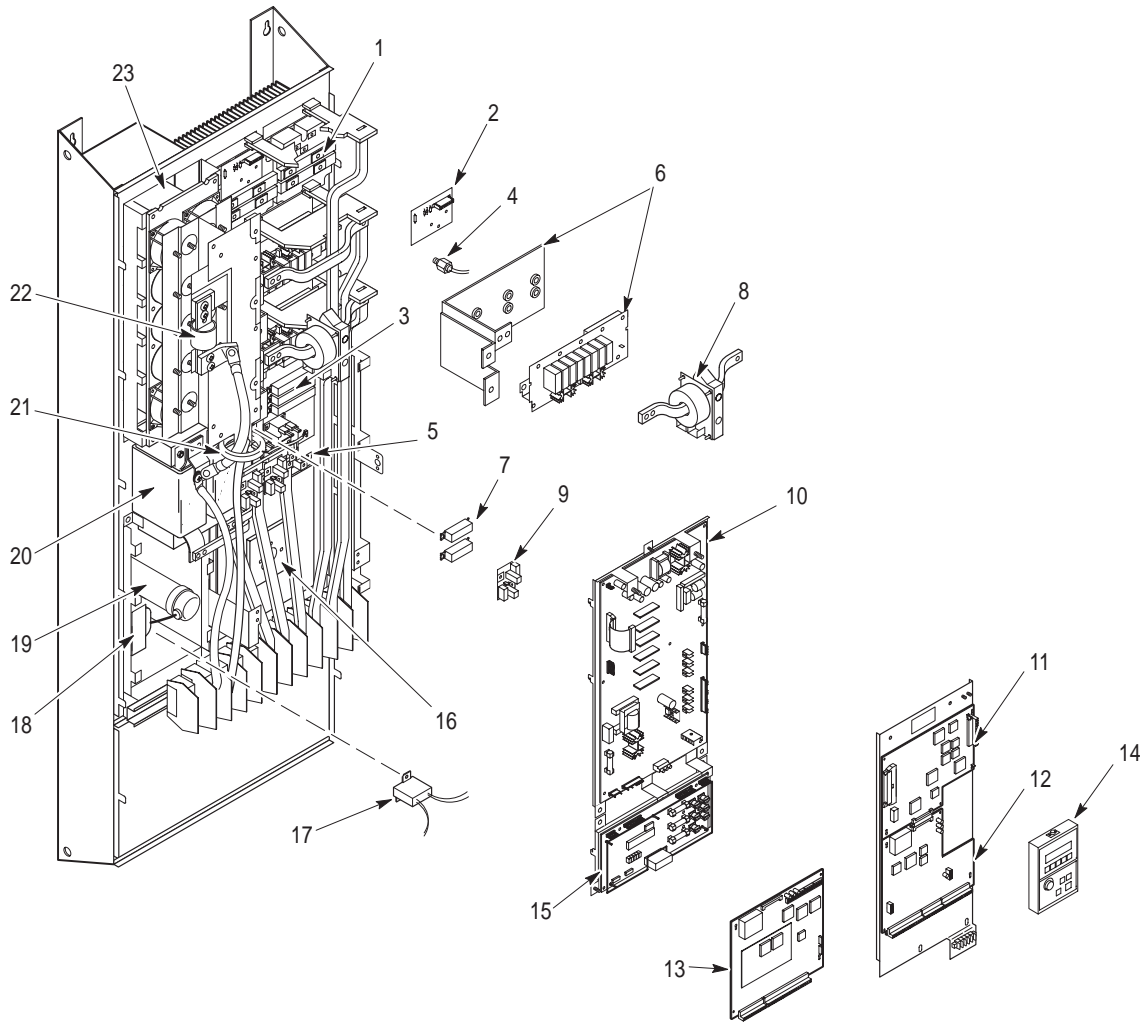

AB0576A

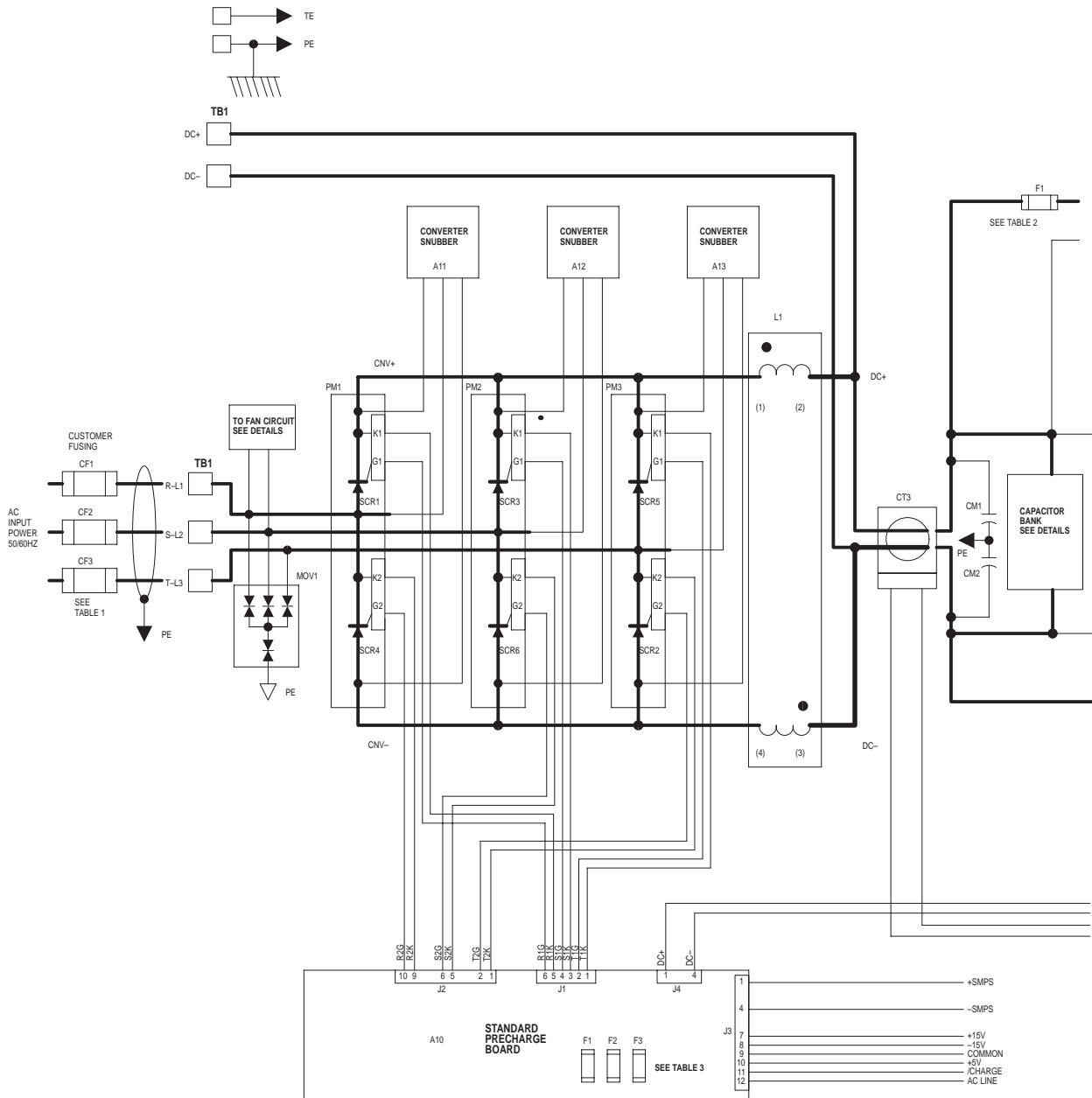

**Table 5.A**  
**Replacement Parts for B150–B250 and C150–C250 Drives**

Callout	Symbol	Description	Location	Replacement Procedures
1	Q1 – Q6	Transistor (Power Module)	Heat Sink	Chapter 4, Power Modules
2	A23 – A28	Power Module Gate Interface Board	Power Module	Chapter 4, Power Modules
3	R20 – R22	Power Module Snubber Resistor	Heat Sink	Chapter 2, Removing a Power Module Snubber Board
4	ST	Thermistor	Heat Sink	Chapter 4, Thermistor
5	SCR1 – SCR3	Input Rectifier	Heat Sink	Chapter 4, Input Rectifiers
6	SNUBBER BOARD	Power Module Bus Bar and Snubber Board	Power Module	Chapter 2, Removing a Power Module Snubber Board
7	R1 – R3	Load-Sharing Resistor	Heat Sink	Chapter 4, Bus Capacitor Bank
8	CT1, CT2	LEM	Bus Bar	Chapter 4, LEMs
9	SCR SNUBBER BOARD	Input Rectifier Snubber Board	Input Rectifier	Chapter 2, Removing the Input Rectifier Snubber Board
10	BASEDR/PWRSPLY	Gate Driver Board	Gate Driver/Precharge Board Mounting Plate	Chapter 2, Removing the Gate Driver Board
11	MAIN CTL	Main Control Board	Control Board/Adapter Mounting Plate	Chapter 2, Removing the Main Control Board from the Mounting Plate
12	GT2	Standard Adapter Board	Control Board/Adapter Mounting Plate	Chapter 2, Removing the Standard Adapter Board
13	GT1	PLC Comm Adapter Board	Control Board/Adapter Mounting Plate	Chapter 2, Removing the PLC Comm Adapter Board
14	HIM	Human Interface Module	Enclosure Cover	Chapter 1, Module Removal
15	PRECHARGE	Precharge Board	Gate Driver/Precharge Board Mounting Plate	Chapter 2, Removing the Precharge Board
16	FAN	Fan	Main Chassis	Chapter 4, Fan and Transformer
17	MOV	MOV Surge Suppressor	Main Chassis	Chapter 4, Fan and Transformer
18	T1	Fan Transformer	Main Chassis	Chapter 2, Removing the Input Rectifier Snubber Board
19	C-HB1	Fan Capacitor	Main Chassis	Chapter 4, Fan and Transformer
20	L1	DC Bus Inductor	Main Chassis	Chapter 4, DC Bus Inductor L1
21	CT3	Ground Sense CT	—	Chapter 4, Ground Sense CT
22	F1	Bus Fuse	—	Chapter 4, Bus Fuse F1
23	C1 – C10	Bus Capacitors	Main Chassis	Chapter 4, Bus Capacitor Bank

**This Page Intentionally Left Blank**

**Schematics — 150 – 300 HP 1336  
FORCE Drives**



SCHEMATIC DIAGRAM  
STAND ALONE UNIT  
BULLETIN 1336 FORCE  
150 – 250 HP 380/460 VAC  
150 – 300 HP 575 VAC

AB0720A

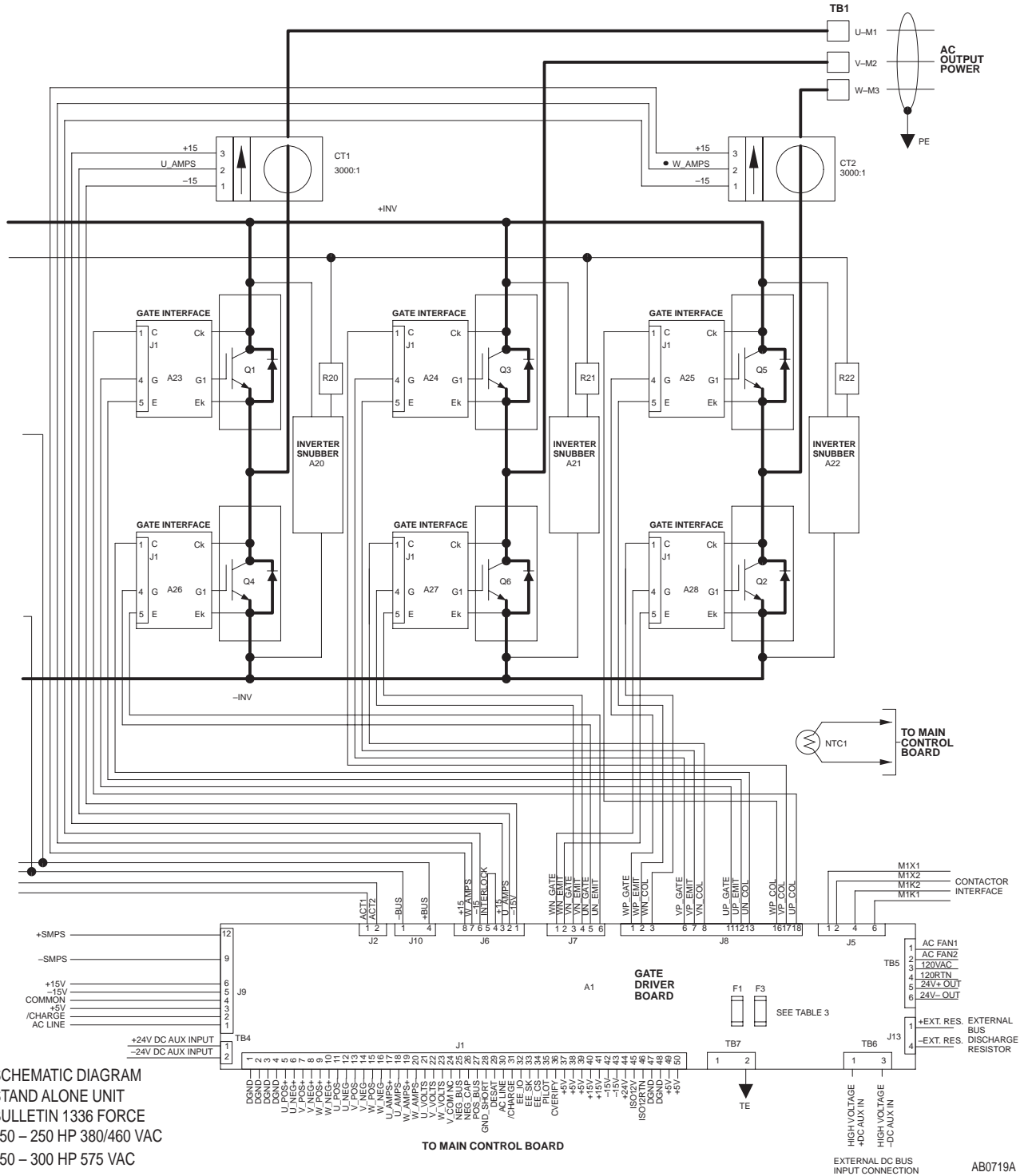

**SCHEMATIC DIAGRAM  
STAND ALONE UNIT  
BULLETIN 1336 FORCE  
150 – 250 HP 380/460 VAC  
150 – 300 HP 575 VAC**

TO MAIN CONTROL BOARD

EXTERNAL DC BUS  
INPUT CONNECTION

AB0719A

Fan Circuit Detail

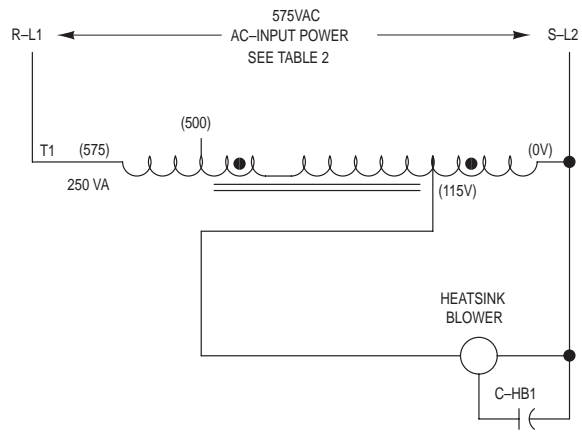
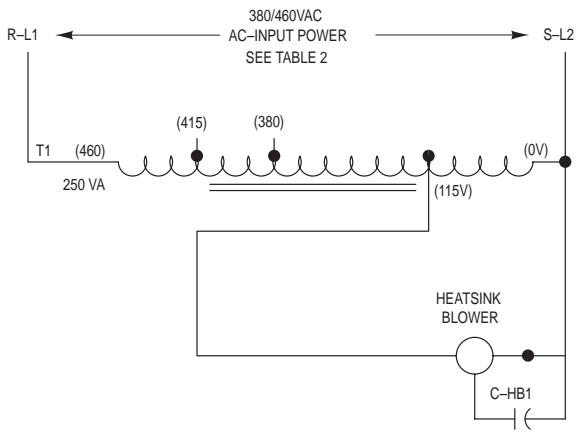

Capacitor Detail

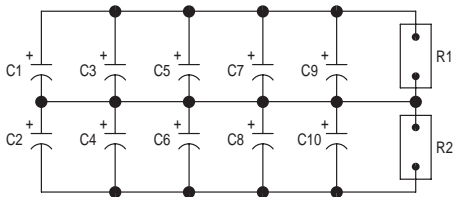

DETAIL 1 – 380/460 VAC

NOTES: – DETAIL 1:

1. C1 THRU C10 ARE 400 VDC CAPACITORS.
2. FOR 150HP C5 AND C6 ARE NOT SUPPLIED.

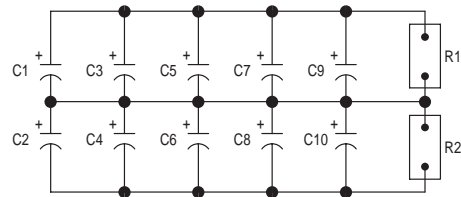

DETAIL 2 – 575 VAC

NOTES: – DETAIL 2:

1. C1 THRU C10 ARE 500 VDC CAPACITORS.
2. FOR 150 HP C3, C4, C7, C8 ARE NOT SUPPLIED.
3. FOR 200 HP C5 AND C6 ARE NOT SUPPLIED.

AB0721A

TABLE 1: CUSTOMER FUSING  
 BASED ON MAXIMUM DRIVE RATING THE FOLLOWING FUSES OR  
 APPROVED EQUIVALENT MUST BE USED:

HORSEPOWER	380/460VAC FUSE CURRENT/TYPE	575VAC FUSE CURRENT/TYPE
150	300A/UL CLASS CC, T OR J	225A/UL CLASS CC, T OR J
200	400A/UL CLASS CC, T OR J	350A/UL CLASS CC, T OR J
250	450A/UL CLASS CC, T OR J	400A/UL CLASS CC, T OR J
300	NOT APPLICABLE	400A/UL CLASS SPP,FWP OR A70Q

TABLE 2: THE INVERTER DC + BUS FUSE WILL REMAIN ONE AMP RATING.  
 FOR ALL UNITES IN THIS FRAME, THE TABLE BELOW DEFINES  
 THE FUSE RATING.

DRIVE HORSEPOWER, INPUT VOLTAGE	FUSE INFORMATION		
	RATING	TYPE	P/N
150/200/250 HP – 380/460/575 VAC	600A	A70Q600-4	25178-310-19
300 HP – 575 VAC	600A	A70Q600-4	25178-310-19

TABLE 3: THE FOLLOWING IS A LISTING OF ALL PRINTED CIRCUIT  
 ASSEMBLIES VERSUS FUSE & DOCUMENTATION INFORMATION.

ITEM	B/M	SCHEMATIC DIAGRAM	FUSE INFORMATION			
			DESIGNATOR	RATING	TYPE	P/N
A1	74101-169-XX	74101-167	F1	1.0A/600V	KTK-R-1	25172-260-08
			F3	1.5A/600V	KTK-R-1.5	25172-260-09
A10	74101-181-XX	74101-179	F1-F3	1.5A/600V	KTK-R-1.5	25172-260-09
A11-13	74101-367-XX	74101-365	NONE			
A20-22	74101-363-XX	74101-361	NONE			
A23-28	74101-371-XX	74101-369	NONE			

AB0722A

**This Page Intentionally Left Blank**



## Glossary

**AC Contactor:** An alternating-current (AC) contactor is designed for the specific purpose of establishing or interrupting an AC Power circuit.

**Adjustable Speed:** The concept of varying the speed of a motor, either manually or automatically. The desired operating speed (set speed) is relatively constant regardless of load.

**Adjustable Speed Drive (Electrical):** The adjustable speed drive is comprised of the motor, drive controller and operator's controls (either manual or automatic).

**Ambient Temperature:** The temperature of the medium (air, water, earth) into which the heat of the equipment is dissipated.

**Base Speed:** The manufacturer's nameplate rating where the motor will develop rated power at rated load and voltage. With DC drives, it is commonly the point where full armature voltage is applied with full-rated field excitation. With AC systems, it is commonly the point where 60 Hz is applied to the induction motor.

**BR:** Refer to *Bridge Rectifier*.

**Braking:** A method of stopping or reducing the time required to stop an AC motor, and can be accomplished in several ways:

1. DC-Injection braking (AC drives) — A method which produces electromagnetic braking forces in the motor by removing 2 AC motor (stator) phases and injecting DC current. The result is a linear braking characteristic (ramp) that does not diminish with motor speed. Application is normally limited to 10–20% of rated motor speed due to increased heating in the rotor.
2. Dynamic braking (AC drives) — A method which produces electromagnetic braking forces in the motor by dissipating generated power into the DC bus through a resistive load. Braking force remains constant and is only limited by the thermal capacity of the resistors. The result is a linear braking characteristic (ramp) that does not diminish with motor speed.
3. Regenerative braking — A method which produces electromagnetic braking forces in the motor by electronically controlling the return of generated power to the AC supply. The result is a controllable linear braking characteristic (ramp) that does not diminish with motor speed.

4. **Motor-mounted or separately-mounted brake** — A positive-action, mechanical friction device. Normal configuration is such that when the power is removed, the brake is set. This can be used as a holding brake. (Note: A separately mounted brake is not one which is located on some part of the mechanical drive train other than the motor.)

**Breakaway Torque:** The torque required to start a machine from standstill. Breakaway torque is always greater than the torque needed to maintain motion.

**Breakdown Torque:** The breakdown torque of an AC motor is the maximum torque which it will develop with rated voltage applied at rated frequency.

**Bridge Rectifier (Diode, SCR):** A non-controlled, full-wave rectifier that produces a constant, rectified, DC voltage. An SCR bridge rectifier is a full-wave rectifier with a DC output that can be controlled by switching on the gate control element.

**Bridge Rectifier:** A full-wave rectifier that conducts current in only one direction of the input current. AC applied to the input results in approximate DC at the output.

**British Thermal Unit (BTU):** The quantity of heat required to raise one pound of water by one degree Fahrenheit.

**BTU:** Refer to *British Thermal Unit*.

**Bus:** A single path or multiple parallel paths for power or data signals to which several devices may be connected at the same time. A bus may have several sources of supply and/or several sources of demand.

**Bus Sense:** A signal transducer that generates a signal proportional to the current in the drive's DC bus. The control logic uses this signal to sense the presence or absence of bus voltage.

**CEMF:** Refer to *Counter Electromotive Force*.

**CMOS:** Complimentary Metallic Oxide Semiconductor. A semiconductor device in which an electric field controls the conductance of a channel under a metal electrode called a gate.

**Cogging:** A condition in which a motor does not rotate smoothly but steps or jerks from one position to another during shaft revolution. Cogging is most pronounced at low motor speeds and can cause objectionable vibrations in the driven machinery.

**Constant Torque Range:** A speed range in which a motor is capable of delivering a constant torque, subject to cooling limitations of the motor.

**Constant Voltage Range:** (AC Drives) The range of motor operation where the drive's output voltage is held constant as output frequency is varied. This speed range produces motor performance similar to a DC drive's constant horsepower range.

**Constant Volts per Hertz (V/Hz):** The V/Hz relationship exists in AC drives where the output voltage is directly proportional to frequency. This type of operation produces constant rated torque as the motor's speed varies.

**Continuous Duty (CONT):** A motor that can continue to operate without stopping and remain within the insulation temperature limits after it has reached normal operating (equilibrium) temperature.

**Converter:**

1. A device for changing AC to DC. This is accomplished through use of a diode rectifier or thyristor rectifier circuit.
2. A device for changing AC to DC to AC (e.g., adjustable frequency drive). A frequency converter, such as that found in an adjustable frequency drive, consists of a rectifier, a DC intermediate circuit, an inverter, and a control unit.

**Counter Electromotive Force (CEMF):** The product of a motor armature rotating in a magnetic field. This generating action takes place whenever a motor is rotating. Under stable motoring conditions the generated voltage (CEMF) is equal to the voltage supplied to the motor minus small losses. However, the polarity of the CEMF is opposite to that of the power being supplied to the armature.

**Current Limiting:** An electronic method of limiting the maximum current available to the motor. This is adjustable so that the motor's maximum current can be controlled. It can also be preset as a protective device to protect both the motor and the control from extended overloads.

**DC Boost:** Compensates for the voltage drop across the resistance of an AC motor circuit and the resulting reduction in torque.

**DC Bus:** A drive's power structure that transmits a rectified AC line power from the bridge rectifier to the output transistors.

**DC Hold:** Describes a "holding brake" function to stop motor rotation after a ramp-to-stop function is activated.

**Diode:** A solid-state uni-directional conductor.

**Drift:** A slow change in some characteristic of a device. For a drive, it is the deviation from the initial set speed with no load change over a specific time period. Normally the drive must be operated for a specified warm-up time at a specified ambient temperature before drift specifications apply. Drift is normally caused by random changes in operating characteristics of various control components.

**Drive Controller (Variable Speed Drive) (Drive):** An electronic device that can control the speed, torque, horsepower, and direction of an AC or DC motor.

1. PWM drive — is a motor drive using pulse-width modulation techniques to control power to the motor. A high-efficiency drive used for high-response applications.
2. SCR drive — is a motor drive that uses SCRs as the power control elements. Usually used for low-bandwidth high-power applications.
3. Servo drive — is a motor drive that uses internal feedback loops for motor current and/or velocity.
4. Vector drive — is an AC static motor drive using power-control techniques that produce motor performance similar to DC static drives.

**Duty Cycle:**

1. The ratio of working time to total time for an intermittently operating device. Usually expressed as a percentage.
2. The ratio of pulse width to the interval between like portions of successive pulses. Usually expressed as a percentage.

**Dynamic Braking:** Refer to *Braking*.

**Efficiency:** Ratio of output to input, indicated by a percentage. In a motor, it is the effectiveness with which the motor converts electrical energy into mechanical energy. In a power supply, it is the effectiveness with which the power supply converts AC power into DC power.

**Electrostatic Discharge (ESD):** A static-electricity discharge that may damage drive components. Refer to the ESD precautions found in this manual to guard against damage to drive components.

**Enable:** To activate logic by the removal of a suppression signal.

**Enclosure:** The housing in which equipment is mounted. They are available in designs for various environmental conditions. Refer to NEMA standard for specifications of different types of enclosures.

**ENUM (Enumeration):** An ANSI C standard extension to the C language. An ENUM is a set of named integer constants that specify all the legal values a variable of a given type may have. The keyword ENUM signals the start of an enumeration type.

**ESD:** Refer to *Electrostatic Discharge*.

**Floating Ground:** An electrical circuit common which is not at earth ground potential or the same ground potential as circuitry with which it interfaces. A voltage difference can exist between the floating ground and earth ground.

**Force:** The tendency to change the motion of an object with an exertion of energy from a separate source.

**Full Load Torque:** The full-load torque of a motor is the torque necessary to produce rated horsepower at full-load speed.

**Gate:**

1. A logic element that blocks or passes a signal, depending on the status of specified input signals.
2. The control element of an SCR.

**GND Sense:** A current transducer that detects an unequal or imbalanced current in the three-phase AC line or DC bus of the drive. The imbalance indicates an output ground fault condition.

**Horsepower (hp):** A unit of power: 1 hp = 33,000 ft-lb/min. = 746 watts.

**IEC:** International Electrotechnical Commission.

**IGBT:** Refer to *Insulated Gate Bipolar Transistor*.

**Induction Motor:** An induction motor is an alternating-current motor in which the primary winding on one member is connected to the power source. A secondary winding on the other member carries the induced current. There is no physical electrical connection to the secondary winding; its current is induced.

**Inertia:** A measure of a body's resistance to change in velocity, whether a body is at rest or moving at a constant velocity. The velocity can be either linear or rotational. The moment of inertia ( $WK^2$ ) is the product of the weight ( $W$ ) of an object and the square of the radius of gyration ( $K^2$ ). The radius of gyration is a measure of how the mass of the object is distributed about the axis of rotation.  $WK^2$  is usually expressed in units of lb-ft<sup>2</sup>.

**Insulated Gate Bipolar Transistor (IGBT):** A type of transistor commonly used in drive-control devices.

**Integral-Horsepower Motor:** A motor that has a continuous rating of 1 hp or more, built into a frame.

**International Organization for Standards (ISO):** An organization established to promote development of international standards.

**Interposing Relay:** An interposing relay is a relay that accepts control signals of one logic level in order to provide isolated contact signals in a circuit operating at a different logic level.

**Inverter:**

1. An AC adjustable frequency drive.
2. A particular section of an AC drive. This section uses the DC voltage from a previous circuit stage (intermediate DC circuit) to produce a pulse-width-modulated or stepped AC current or voltage waveform that has characteristics similar to the desired sine-wave frequency.
3. A circuit whose output signal is the inverse of its input (a positive-going pulse is inverted to a negative-going pulse, and vice versa).

**ISO:** Refer to *International Organization for Standards*.

**Isolation Transformer:**

1. A transformer that provides DC isolation from other equipment not connected to that transformer secondary.
2. A transformer that provides noise isolation between the primary and secondary by such means as a Faraday shield.

**Jogging:**

1. In a numerical control system, an operator manually generating motion (continuously or incrementally) by closing a switch.
2. An operator generating motion by closing a switch.

**Kinetic Energy:** The energy of motion of a moving body.

**LAD:** Refer to *Linear Acceleration/Deceleration*.

**LEM:** A hall-effect current transducer that senses drive output current and generates a signal for the control logic.

**Linear Acceleration/Deceleration (LAD):** A circuit that controls the rate at which a motor is allowed to accelerate to a set speed or decelerate to zero speed. On most drives, this circuit is adjustable and can be set to accommodate a particular application.

**Linearity:** A measure of how closely a characteristic follows a straight-line function.

**Locked-Rotor Current:** Steady-state current taken from the line current with the a rotor at standstill (at rated voltage and frequency). This is the current when starting the motor and load.

**Locked-Rotor Torque:** The minimum torque that a motor will develop at rest for all angular positions of the rotor (with rated voltage applied at rated frequency).

**Megger Test:** A test used to measure an insulation system's resistance. This is usually measured in megohms by applying a high voltage.

**MOV:** Refer to *Surge Protection*.

**National Electrical Code (NEC):** A set of regulations governing the construction and installation of electrical wiring and apparatus, established by the National Fire Protection Association and suitable for mandatory application by governing bodies exercising legal jurisdiction. It is widely used by state and local authorities within the United States.

**National Electrical Manufacturer's Association (NEMA):** A non-profit organization organized and supported by electrical equipment and supply manufacturers. Some NEMA motor standards include horsepower (hp) ratings, speeds, frame sizes and dimensions, torques, and drive enclosures.

**NEC:** Refer to *National Electrical Code*.

**Negative Slope:** The location on a V/Hz curve where the break voltage exceeds the base voltage.

**NEMA:** Refer to *National Electrical Manufacturer's Association*.

**Offset:** The steady-state deviation of a controlled variable from a fixed setpoint.

**Op Amp:** An operational amplifier. A high-gain stable linear DC amplifier that is designed to be used with external circuit elements.

**Open Loop System:** A control system that has no means of comparing the output with the input for control purposes.

**Overload Capacity:** The ability of the drive to withstand currents beyond the system's continuous rating. It is normally specified as a percentage of full-load current endured for a specified time period. Overload capacity is defined by NEMA as 150% of rated full load current for one minute for "standard industrial DC motors."

**PC:**

1. Personal Computer.
2. Programmable Controller.
3. Printed Circuit.

**Plugging:** A type of motor braking provided by reversing either line voltage polarity or phase sequence so that the motor develops a counter torque that exerts a retarding force to brake the motor.

**Pot:** A potentiometer, or variable resistor.

**Power:** Work done per unit of time. Measured in horsepower (hp) or watts (W): 1 hp = 33,000 ft-lb/min. = 746 W.

**Power Factor (Displacement):** A measurement of the time phase difference between the fundamental voltage and fundamental current in an AC circuit. It represents the cosine of the phase angle difference.

$$F_p = \cos (\alpha - \beta)$$

**Power Factor (Distortion):** A measurement of the ratio of the real power (kW) to the apparent power (kVA). Distortion power factor takes into account harmonic voltage and current distortion as well as voltage-to-current displacement.

**Preform:** A flexible material used between an electronic component and the heat sink to which the component is attached. Preform provides maximum heat dissipation from the component to the heat sink.

**Preset Speed:** Describes one or more fixed speeds at which a drive operates.

**Programmable Controller:** A solid-state control system that has a user-programmable memory for storage of instructions to implement specific functions such as I/O control, logic, timing, counting, report generation, communication, arithmetic, and data file manipulation. A controller consists of a central processor, input/output interface, and memory. A controller is designed as an industrial control system.

**Pull-In Torque:** The maximum constant torque to which a synchronous motor accelerates into synchronism at rated voltage and frequency.

**Pull-Out Torque:** The maximum running torque of a synchronous motor.



**Pull-Up Torque:** The torque required to accelerate the load from standstill to full speed (where breakdown torque occurs), expressed in percent of running torque. It is the torque required not only to overcome friction, windage, and product loading but also to overcome the inertia of the machine. The torque required by a machine may not be constant after the machine has started to turn. This load type is characteristic of fans, centrifugal pumps, and certain machine tools.

**PWM:** Pulse-width Modulation. A technique used to eliminate or reduce unwanted harmonic frequencies when inverting DC voltage to sine wave AC.

**Reactance:** Pure inductance or capacitance, expressed in ohms, in a circuit. It is the component of impedance to alternating current that is not resistance.

**Rectifier:** A device that conducts current in only one direction, thereby transforming alternating current to direct current.

**Regeneration:** (AC drives) When the rotor synchronous frequency is greater than the applied frequency.

**Regenerative Braking:** Slows or stops a motor through regeneration. Refer to *Regeneration* and *Braking*.

**Resolution:** The smallest distinguishable increment into which a quantity can be divided (e.g., position or shaft speed). It is also the degree to which nearly equal values of a quantity can be discriminated. For rotary encoders, it is the number of unique electrically identified positions occurring in 360 degrees of input shaft rotation. For D/A or A/D conversion, may be expressed as the number of bits in the digital value that corresponds to a full-scale analog value.

**SCR:** Silicon Controlled Rectifier. A solid-state uni-directional latching switch.

**Service Factor:** When used on a motor nameplate, a number that indicates how much above the nameplate rating a motor can be loaded without causing serious degradation (i.e., a motor with 1.15 S-F can produce 15% greater torque than one with 1.0 S-F).

**Set Speed:** The desired operating speed.

**Shock Load:** The load seen by a clutch, brake, or motor in a system that transmits high peak loads. This type of load is present in crushers, separators, grinders, conveyors, winches, and cranes.

**Slip:** The difference between rotating magnetic field speed (synchronous speed) and rotor speed of AC induction motors. Usually expressed as a percentage of synchronous speed.

**Slip Compensation:** Monitors motor current and compensates for speed lost due to increased motor slip. The amount of slip is proportional to the motor load.

**Speed Range:** The speed minimum and maximum at which a motor must operate under constant or variable torque load conditions. A 50:1 speed range for a motor with top speed 1800 rpm means the motor must operate as low as 36 rpm and still remain within regulation specification. Controllers are capable of wider controllable speed ranges than motors because there is no thermal limitation, only electrical. Controllable speed range of a motor is limited by the ability to deliver 100% torque below base speed without additional cooling.

**Speed Regulation:** The numerical measure (percent) of how accurately the motor speed can be maintained. It is the percentage of change in speed between full load and no load. The ability of a drive to operate a motor at constant speed (under varying load), without “hunting” (alternately speeding up and slowing down). It is related to both the characteristics of the load being driven and electrical time constants in the drive regulator circuits.

**Surge Protection:** The process of absorbing and clipping voltage transients on an incoming AC power line or control circuit. Surge protectors include MOVs (Metal Oxide Varistors) and specially designed R-C networks.

**Synchronous Speed:** The speed of an AC induction motor’s rotating magnetic field. It is determined by the frequency applied to the stator and the number of magnetic poles present in each phase of the stator windings. Mathematically, it is expressed as: Sync Speed (rpm) = 120 x Applied Freq. (Hz) / Number of poles per phase.

**Torque:** A turning force applied to a shaft, tending to cause rotation. Torque is equal to the force applied, times the radius through which it acts. Torque is measured in pound-feet, ounce-inches, Newton-meters, or gram-centimeters.

**Transducer:** A device that converts one energy form to another (e.g., mechanical to electrical). When a transducer is actuated by signals from one system or medium, it can supply a related signal to the other system or medium.

**Transient:** A momentary power deviation in an electrical or mechanical system.

**Transistor:** An active solid-state semiconductor device.

**Work:** A force moving an object over a distance.  
(work = force x distance)

**This Page Intentionally Left Blank**

## A

Adapter Locations, 1–12  
Audience for this Manual, P–1  
Auxiliary Input, Definition, P–7  
Auxiliary Interlock, Definition, P–7

## B

Bit, Definition, P–7  
Bus Capacitor Bank  
  Illustration, 4–4  
  Installation, 4–6  
  Removal, 4–4  
  Test, 3–10  
Bus Fuse  
  Illustration, 4–22  
  Installation, 4–23  
  Removal, 4–23

## C

Check, Definition, P–7  
Component Test Procedures, 3–1  
Connector, Definition, P–7  
Control Board/Adapter Mounting Plate,  
  Illustration, 2–18  
Control Interface Board  
  Definition, P–8  
  Illustration, 2–10  
  Installation, 2–11  
  Jumper Locations, 1–4  
  Removal, 2–10  
Control Interface Option, 1–3  
Control Logic Wiring, 1–1  
Conventions in this Manual, P–7

## D

DC Bus Inductor L1  
  Illustration, 4–18  
  Installation, 4–19  
  Removal, 4–18  
Default, Definition, P–8  
Drive  
  Enclosure Type, P–6  
  Identification, P–4

  Illustration, 4–3  
  Nameplate Location, P–3  
  Rating, P–6  
Drive Enclosure  
  Illustration, 2–6  
  Installation, 2–7  
  Removal, 2–6

## E

Electrostatic Discharge, P–2  
Enable Input, Definition, P–8  
Enclosure Type, P–6  
ESD, P–2

## F

False, Definition, P–8  
Fan and Transformer  
  Illustration, 4–14  
  Installation, 4–17  
  Removal, 4–15  
Four-Point Mounting, 2–4

## G

Gate Driver Board  
  Illustration, 2–23  
  Installation, 2–24  
  Removal, 2–23  
  Test, 3–3  
Gate Driver Board Mounting Plate,  
  Illustration, 2–20  
Gate Driver/Precharge Board Mounting  
  Plate  
  Installation, 2–22  
  Removal, 2–20  
Ground Sense CT  
  Illustration, 4–20  
  Installation, 4–21  
  Removal, 4–20

## H

High Voltage Shield  
  Illustration, 2–8  
  Installation, 2–9  
  Removal, 2–8

- HIM  
 See *also* Human Interface Module  
 Removal, 1–13
- Human Interface Module (HIM)  
 Adapter Locations, 1–12  
 Description, 1–11  
 Illustration, 1–11  
 Operation, 1–14
- I**
- Input Mode  
 Programming, 1–5  
 Selection, 1–6
- Input Rectifier  
 Illustration, 4–12  
 Installation, 4–13  
 Removal, 4–12  
 Test, 3–13
- Input Rectifier Snubber Board  
 Illustration, 2–32  
 Installation, 2–33  
 Removal, 2–32
- Inputs, Available, 1–5
- Installation Procedures. *See* Procedures
- J**
- Jumper, Definition, P–8
- L**
- LEMs  
 Illustration, 4–24, 4–26  
 Installation, 4–25  
 Removal, 4–24
- Load Sharing Resistor Connections, 4–6
- Local Programming, 1–5
- M**
- Main Control Board  
 Illustration, 2–12  
 Installation, 2–13  
 Removal, 2–12
- Main Control Board Mounting Plate  
 Installation, 2–19  
 Removal, 2–18
- Major Component Replacement. *See* Procedures
- Manual  
 Audience, P–1
- Conventions, P–7  
 Objective, P–1  
 Related Publications, P–9
- Motor Control Board, Removal, 2–14, 2–16
- Mounting  
 Four-Point, 2–4  
 Six-Point, 2–4  
 Two-Point, 2–3
- N**
- Nameplate Location, P–3
- O**
- Objective of this Manual, P–1
- Operation, Human Interface Module, 1–14
- Option  
 Control Interface, 1–3  
 Identification, P–4
- P**
- Parameter, Definition, P–8
- Power Module  
 Illustration, 4–9  
 Installation, 4–11  
 Removal, 4–9  
 Test, 3–7
- Power Module Snubber Board  
 Illustration, 2–29  
 Installation, 2–31  
 Removal, 2–30
- Precautions  
 Electrostatic Discharge, P–2  
 Safety, P–1
- Precharge Board  
 Illustration, 2–27  
 Installation, 2–28  
 Removal, 2–27  
 Test, 3–5
- Precharge Board Mounting Plate  
 Illustration, 2–25  
 Installation, 2–26  
 Removal, 2–25
- Press, Definition, P–8
- Procedures  
 Accessing Internal Drive Components, 2–1  
 Bus Capacitor Bank Installation, 4–6  
 Bus Capacitor Bank Removal, 4–4

Bus Capacitor Bank Test, 3-10  
Bus Fuse, 4-23  
Component Test, 3-1  
Control Board Installation, 2-13  
Control Board Mounting Plate  
Installation, 2-19  
Control Board Removal, 2-12  
Control Board/Adapter Mounting Plate  
Removal, 2-18  
Control Interface Board Installation, 2-11  
Control Interface Board Removal, 2-10  
DC Bus Inductor L1 Installation, 4-19  
DC Bus Inductor L1 Removal, 4-18  
Drive Enclosure Installation, 2-7  
Drive Enclosure Removal, 2-6  
Fan Installation, 4-17  
Fan Removal, 4-15  
Gate Driver Board Installation, 2-24  
Gate Driver Board Removal, 2-23  
Gate Driver Board Test, 3-3  
Ground Sense CT, 4-20, 4-21  
High Voltage Shield, 2-8, 2-9  
Input Rectifier Installation, 4-13  
Input Rectifier Removal, 4-12  
Input Rectifier Test, 3-13  
Major Component Replacement, 4-2  
Power Module Installation, 4-11  
Power Module Removal, 4-9  
Power Module Snubber Board  
Installation, 2-31  
Power Module Snubber Board Removal,  
2-29  
Power Module Test, 3-7  
Precharge Board Installation, 2-28  
Precharge Board Mounting Plate  
Installation, 2-26  
Precharge Board Mounting Plate  
Removal, 2-25  
Precharge Board Removal, 2-27  
Precharge Board Test, 3-5  
Replacement Part, 4-1  
Thermistor Installation, 4-8  
Thermistor Removal, 4-7  
Programming  
Input Mode, 1-5  
Local, 1-5

## R

Rating, Drive, P-6

Related Publications, P-9  
Removal Procedures. *See* Procedures  
Removal, HIM, 1-13  
Replacement Part Procedures, 4-1  
Replacement Parts, 5-1

## S

Safety Precautions, P-1  
Schematics, 6-1  
Six-Point Mounting, 2-4  
Snubber Board, Input Rectifier  
Illustration, 2-32  
Installation, 2-33  
Removal, 2-32  
Snubber Board, Power Module  
Illustration, 2-29  
Installation, 2-31  
Removal, 2-30  
Speed Select, Input State, 1-9

## T

Terminal Block Locations, 1-2  
Thermistor  
Illustration, 4-7  
Installation, 4-8  
Removal, 4-7  
Tools, Required for Service, 2-2, 3-2, 4-2  
Torque  
Four-Point Mounting Sequence, 2-4  
Maximum for TB Terminals, 1-6  
Six-Point Mounting Sequence, 2-4  
Specifications, 2-4  
Two-Point Mounting Sequence, 2-3  
Troubleshooting, Component Test  
Procedures, 3-1  
True, Definition, P-9  
Two-Point Mounting, 2-3

## W

Wire Sizes, 1-6

**This Page Intentionally Left Blank**























# We Want Our Manuals to be the Best!

You can help! Our manuals must meet the needs of you, the user. This is your opportunity to make sure they do just that. By filling out this form you can help us provide the most useful, thorough, and accurate manuals available. Please take a few minutes to tell us what you think. Then mail or FAX this form.

FAX: to your local Allen-Bradley Sales Office or 414/512-8579

PUBLICATION NAME \_\_\_\_\_

PUBLICATION NUMBER, DATE AND PART NUMBER (IF PRESENT) \_\_\_\_\_

✓ **CHECK THE FUNCTION THAT MOST CLEARLY DESCRIBES YOUR JOB.**

- SUGGEST / RESPONSIBLE FOR THE PURCHASE OF EQUIPMENT     MAINTAIN / OPERATE PROGRAMMABLE MACHINERY
- DESIGN / IMPLEMENT ELECTRICAL SYSTEMS                                 TRAIN/EDUCATE MACHINE USERS
- SUPERVISE FLOOR OPERATIONS

✓ **WHAT LEVEL OF EXPERIENCE DO YOU HAVE WITH EACH OF THE FOLLOWING PRODUCTS?**

	NONE	LITTLE	MODERATE	EXTENSIVE
PROGRAMMABLE CONTROL	<input type="checkbox"/>	<input type="checkbox"/>	<input type="checkbox"/>	<input type="checkbox"/>
AC / DC DRIVES	<input type="checkbox"/>	<input type="checkbox"/>	<input type="checkbox"/>	<input type="checkbox"/>
PERSONAL COMPUTERS	<input type="checkbox"/>	<input type="checkbox"/>	<input type="checkbox"/>	<input type="checkbox"/>
NC / CNC CONTROLS	<input type="checkbox"/>	<input type="checkbox"/>	<input type="checkbox"/>	<input type="checkbox"/>
DATA COMMUNICATIONS / LAN	<input type="checkbox"/>	<input type="checkbox"/>	<input type="checkbox"/>	<input type="checkbox"/>

✓ **RATE THE OVERALL QUALITY OF THIS MANUAL BY CIRCLING YOUR RESPONSE BELOW. (1) = POOR (5) = EXCELLENT**

HELPFULNESS OF INDEX / TABLE OF CONTENTS		1	2	3	4	5
CLARITY		1	2	3	4	5
EASE OF USE		1	2	3	4	5
ACCURACY AND COMPLETENESS		1	2	3	4	5
QUALITY COMPARED TO OTHER COMPANIES' MANUALS		1	2	3	4	5
QUALITY COMPARED TO OTHER ALLEN-BRADLEY MANUALS		1	2	3	4	5

✓ **WHAT DID YOU LIKE MOST ABOUT THIS MANUAL?**

✓ **WHAT DID YOU LIKE LEAST ABOUT THIS MANUAL?**

✓ **PLEASE LIST ANY ERRORS YOU FOUND IN THIS MANUAL (REFERENCE PAGE, TABLE, OR FIGURE NUMBERS).**

✓ **DO YOU HAVE ANY ADDITIONAL COMMENTS?**

✓ **COMPLETE THE FOLLOWING.**

NAME \_\_\_\_\_ COMPANY \_\_\_\_\_

TITLE \_\_\_\_\_ DEPARTMENT \_\_\_\_\_

STREET \_\_\_\_\_ CITY \_\_\_\_\_ STATE \_\_\_\_\_ ZIP \_\_\_\_\_

TELEPHONE \_\_\_\_\_ FAX AND/OR E-MAIL \_\_\_\_\_

CUT ALONG DOTTED LINE

FOLD HERE

FOLD HERE



**BUSINESS REPLY MAIL**

FIRST CLASS PERMIT NO. 413 MEQUON, WI

POSTAGE WILL BE PAID BY ADDRESSEE

**ALLEN-BRADLEY**  
**Attn: Marketing Communications**  
**P.O. Box 760**  
Mequon, WI 53092-9907

NO POSTAGE  
NECESSARY  
IF MAILED  
IN THE  
UNITED STATES

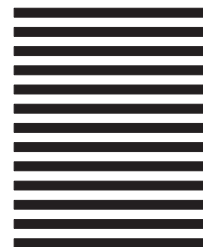

SCANport is a trademark of Allen-Bradley Company, Inc.

PLC is a registered trademark of Allen-Bradley Company, Inc.



Allen-Bradley, a Rockwell Automation Business, has been helping its customers improve productivity and quality for more than 90 years. We design, manufacture and support a broad range of automation products worldwide. They include logic processors, power and motion control devices, operator interfaces, sensors and a variety of software. Rockwell is one of the world's leading technology companies.

## Worldwide representation.



Argentina • Australia • Austria • Bahrain • Belgium • Brazil • Bulgaria • Canada • Chile • China, PRC • Colombia • Costa Rica • Croatia • Cyprus • Czech Republic • Denmark • Ecuador • Egypt • El Salvador • Finland • France • Germany • Greece • Guatemala • Honduras • Hong Kong • Hungary • Iceland • India • Indonesia • Ireland • Israel • Italy • Jamaica • Japan • Jordan • Korea • Kuwait • Lebanon • Malaysia • Mexico • Netherlands • New Zealand • Norway • Pakistan • Peru • Philippines • Poland • Portugal • Puerto Rico • Qatar • Romania • Russia-CIS • Saudi Arabia • Singapore • Slovakia • Slovenia • South Africa, Republic • Spain • Sweden • Switzerland • Taiwan • Thailand • Turkey • United Arab Emirates • United Kingdom • United States • Uruguay • Venezuela • Yugoslavia

Allen-Bradley Headquarters, 1201 South Second Street, Milwaukee, WI 53204 USA, Tel: (1) 414 382-2000 Fax: (1) 414 382-4444